



**ENCLOSURE THERMAL
MANAGEMENT**





The history of Cosmotec began in 1989, in Peschiera del Garda, from the dream of people who strongly believed in their experience in industrial air conditioning and in sharing it with their customers.

Shortly after the production of the first units and the beginning of export worldwide, the need to expand the product range to meet all the **Thermal Management needs** opened up; this led to the birth of the industrial refrigeration line, a major challenge that saw Cosmotec competing on an equal footing with important players in the industry, asserting what is its most distinctive trait: working closely with customers, providing products and solutions that can solve their needs.

The approach chosen to meet market demands is **lean and effective**, a typical example of Italian flexibility, coupled with the solidity represented by the German STULZ group, which Cosmotec joined in 2001.

With STULZ, the product lines expanded to include telecommunications and new ranges of chillers with increasingly higher capacities. The speed of product renewal grew dramatically, and to keep up with the needs of the markets, Cosmotec decided to invest in employee training, production quality and efficiency, product engineering, and, in addition, expanded its production area, with new lines and a state-of-the art **Climatic Chamber**.

The company's efforts are currently aimed at maintaining the efficiency and flexibility of its product ranges at the highest levels: the "**Innovation Center**" was created with this goal, in order to allow the development and testing of new technologies that meet the needs of **sustainability and efficiency** required by today's market.

“ All the achievements Cosmotec has made so far and those to come have been possible thanks to the commitment, ideas and work of the people who make it up and who help make it grow every day ”

Paolo Perotti - CEO and Cosmotec Founder



Foundation Year

1989



Employees

250



Worldwide partners

130



Units per year

10000

Our Values

The key to Cosmotec's success lies in its continuous **innovation**, ability and **flexibility** in handling each project, from its conception developed in cooperation with the customer, through to installation, maintenance and service, each time studying specific solutions to the needs of each individual plant and application.

Enthusiasm, the drive to strive for excellence and for new solutions in step with customer demands, attention to **workers' health and safety** and to the **environment**, transparency and acting responsibly: these are the values by which Cosmotec is inspired by and by which it is guided every day.

Through offering highly specialized services and products in high-tech fields, we contribute to the growth of the company team and our clients.



SUSTAINABILITY AND ENVIRONMENTAL RESPONSIBILITY

We strive to reduce the company's environmental footprint and handle product design, development and production in a way that minimises environmental impact throughout its life cycle.



PEOPLE AND WORK ETHICS

We are committed to empowering people, identifying and developing talents and creating an environment based on trust, respect and personal well-being. We base all our internal and external relationships on transparency and fairness. We work daily to ensure that all employees work under the safest conditions.



RELIABILITY

We conceive, design, develop and propose our solutions and services in such a way as to ensure continuity of service over time.



INNOVATION

we are committed to introducing new ways of designing, producing and selling goods or services, pursuing the continuous improvement of our offer.



FOCUS ON CUSTOMER AND QUALITY

we offer scalable solutions and share our expertise by gathering, intercepting and anticipating customers' implicit or expressed needs and market trends.

The Value of People

The company's most valuable resource is undoubtedly its people. They are the strength for the continuous development of activities and the achievement of success.

A highly specialised team, capable of proposing and implementing solutions with the highest technological level for the industrial sector, and able to fulfil the specific requirements of each individual customer, following them through every stage of the project and beyond.

Making cooling greener, one step at a time



Cosmotec strongly believes in the duty to contribute to decreasing and improve the environmental impacts associated with its activities and products.

In the Company

One of Cosmotec's main goals is the **continuous improvement of environmental performance**, to be achieved both through a reduction in wastage of resources (such as raw materials and energy) and through greater control of environmental costs, related to the treatment (disposal/recovery) of waste.

With that in mind, the company has achieved the following certifications:



ISO 14001 (Environmental Management System): ensuring a business model based on sustainability and reducing the environmental impact of products and the entire production process in order to provide customers with a service that meets current environmental standards. All activities that may affect the environment are assessed and controlled in accordance with current regulations.



ISO 50001 (Energy Management System): It aims to improve the company's energy performance, such as reducing energy consumption and related costs; reducing CO2 emissions.

Furthermore, the focus on environmental issues led to the decision to adopt a policy of reducing the use of paper documentation.



Paperless Documentation: our units are accompanied by the instructions for safe use and CE declaration, while the rest of the documentation will be available on Adam, our free App, downloadable on our website.

In the Products



To fight climate change and reduce greenhouse gas emissions, specific regulations have been introduced, including Regulation No. 517/2014, which imposes the phase-down of HFCs.

Cosmotec has decided to use low GWP (Global Warming Potential) gases, which significantly **reduce the carbon footprint and environmental impact of our products.**



Improved performance and reduced power consumption for high energy efficiency.

- **EER** (Energy Efficiency Ratio): our air conditioners boast the best values in the business

- **SEPR** (Seasonal Energy Performance Ratio): chillers in the Cosmotec line comply with the Ecodesign regulation and achieve high SEPR values

Service

The knowledge we have acquired developing industrial air conditioning and refrigeration systems, allows us to offer our customers a complete service, from the design of the systems to the supply of the machines, from the Start Up phase to the ordinary and extraordinary maintenance.

The level of complexity and precision required in today's production processes require a high level of control and reliability. The management of temperatures and heat disposal is one of the critical issues to be addressed, considering the uniqueness of each process and application.

Our technical assistance is also able to guarantee a remote assistance service: Cosmotec, always attentive to the needs of its customers, has developed and launched on the market a range of technologically advanced controllers that guarantee connectivity wherever you are. And thanks to connectivity, our support team can be at your side in real time, wherever you are, and give you advice and suggestions on how to improve performance, solve any problems and check the operation of your units.

Please visit our dedicated website, www.cosmotecservice.com, to discover our offer and find the contacts of our international service network!

Provided Services



Advice and Planning

Support from the planning phase through to installation and start-up of the system



Positioning and Installation

We guarantee the correct operation of equipment and related systems



Startup

We guarantee perfect commissioning and start-up of the entire system, with customised solutions



Maintenance contracts

A preventive and routine maintenance plan, ensuring constant plant efficiency



Availability

With guaranteed response times



Training

Programme of high-quality training courses with technical content



Remote Assistance

At your side in real time, with the help of augmented reality devices



Spare Parts

Supply of spare parts and repair service both in-house and on site

Selection & Monitoring Softwares

What is the purpose of Cosmotec software?

The correct cooling of industrial plants is vital for the operation of companies, as is the ability to **monitor, even remotely**, that all processes are running smoothly.

In order to be at your side at all times, from planning (Web Select) to monitoring (Adam), we have developed two software packages, which we make available to you free of charge.

WEB SELECT

Helping you choose

Designing your own air conditioning system for industrial applications can be particularly complex, due to the many variables that need to be considered in the choice. To enable you to start planning independently, we have developed Web Select, a web-based software that will guide you in **making the best choice for your application's** air conditioning.

Web Select includes the following Cosmotec ranges:

- Air Conditioners
- Heat Exchangers
- Wall and roof filter fans

How to use Web Select

To use our software, you do not need to install any software, just go to www.cosmotec.it/software/cosmotec-web-select/ and follow the instructions. Available for Explorer 10, Chrome, Firefox
Credentials are required for access, which you can obtain free of charge by writing to setup.cva@stulz.it



Who's Adam?

This is the new app that records your Cosmotec units and imports them onto your mobile devices. Thanks to Adam you will have **access to our entire sales and technical documentation**.

It's also possible to organise, monitor and report faults for for all Cosmotec units equipped with a SEC.blue electronic controller or integrated Ethernet port.

Why using Adam?

So you always have all the information at your fingertips, reducing the time needed for commissioning, maintenance, analysis and troubleshooting.

Downloading Adam

Downloading our app is easy:

- via smartphone or tablet iOS e Android (Google Play Services requires for geolocalization & OCR): download at <https://app.stulz.it>
- With a **PC** running Windows (in the versions currently supported by Microsoft on x86-64 architecture) download at <https://app.stulz.it/Adam.msi>

Industrial air conditioners for electrical panels

How and why to choose an air conditioning system for the electrical panel

Why cool an electrical panel?

The cooling of electrical panels or cabinets is essential in any application to ensure the proper functioning of internal components and production processes, **preventing and avoiding production and/or distribution downtime**.

Cosmotec products offer protection against:

- the formation of high temperature and high humidity and consequently overheating and condensation
- the infiltration of dust and/or sand, corrosive agents, etc.

to prevent component wear, derating and failure, thus ensuring **reliability, safety** and **efficiency**.

Main factors influencing the choice of air conditioning type

The choice of air conditioning solution is mainly determined by the following factors:

- **application:** Indoor, cabinet positioned inside a building, or Outdoor, cabinet positioned in an outdoor environment
- **air quality:** presence of humidity, dust, oils
- **reference temperatures:** internal (T_i) and external (T_e) and the ratio between them ($T_i > T_e$, $T_i < T_e$)
- **presence of chilled water**

Industrial air conditioners for electrical panels

Air conditioners for electrical cabinets exploit the principle of a refrigerated circuit using R134a (HFC) refrigerant gas, guarantee precise temperature control and offer simple installation on the electrical panel. Air conditioners are mainly recommended if:

- the outside air has a higher temperature value than the inside air
- the ambient air is extremely oily or dusty
- outside air and humidity must not enter the electrical cabinet
- no hydraulic circuit is to be provided





Protherm

Wall mounted air conditioner

Application: Indoor (CVE) Outdoor (CVO)

External /semi-flush (CVE07-15-500S) mounting

Page 18



Compact Protherm

Wall mounted air conditioner

Application: Indoor (CNE) Outdoor (CNO)

External mounting on cabinets with reduced depth

Page 30



Slim In

Wall mounted air conditioner

Application: Indoor

Flush, semi-flush, external mounting

For the conditioning of electrical panels where space is at a premium

Page 35



Flex In

Inverter air conditioner

Application: Indoor

Flush, semi-flush, external mounting

Higher efficiency and high savings

Page 40



TOP II

Roof air conditioner

Application: Indoor

Roof mounting

Page 43

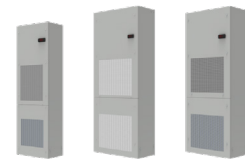

Module

Wall mounted air conditioner

Application: Indoor

External mounting

For the cooling of modular enclosures with high thermal loads

Page 49



Smart

Wall mounted air conditioner

Application: Indoor

External mounting

Air conditioners for horizontal wall mounting

Page 51

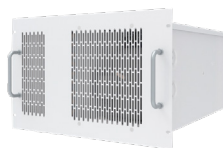

Rack

Rack air conditioner

Application: Indoor

Suitable for cooling 19" racks (7 unit footprint)

Page 52



Predator

Wall mounted air conditioner

Application: Outdoor

Flush, semi-flush, external mounting

Integrated free-cooling for high energy savings

Page 53

Overview Air Conditioners Coolig Capacity

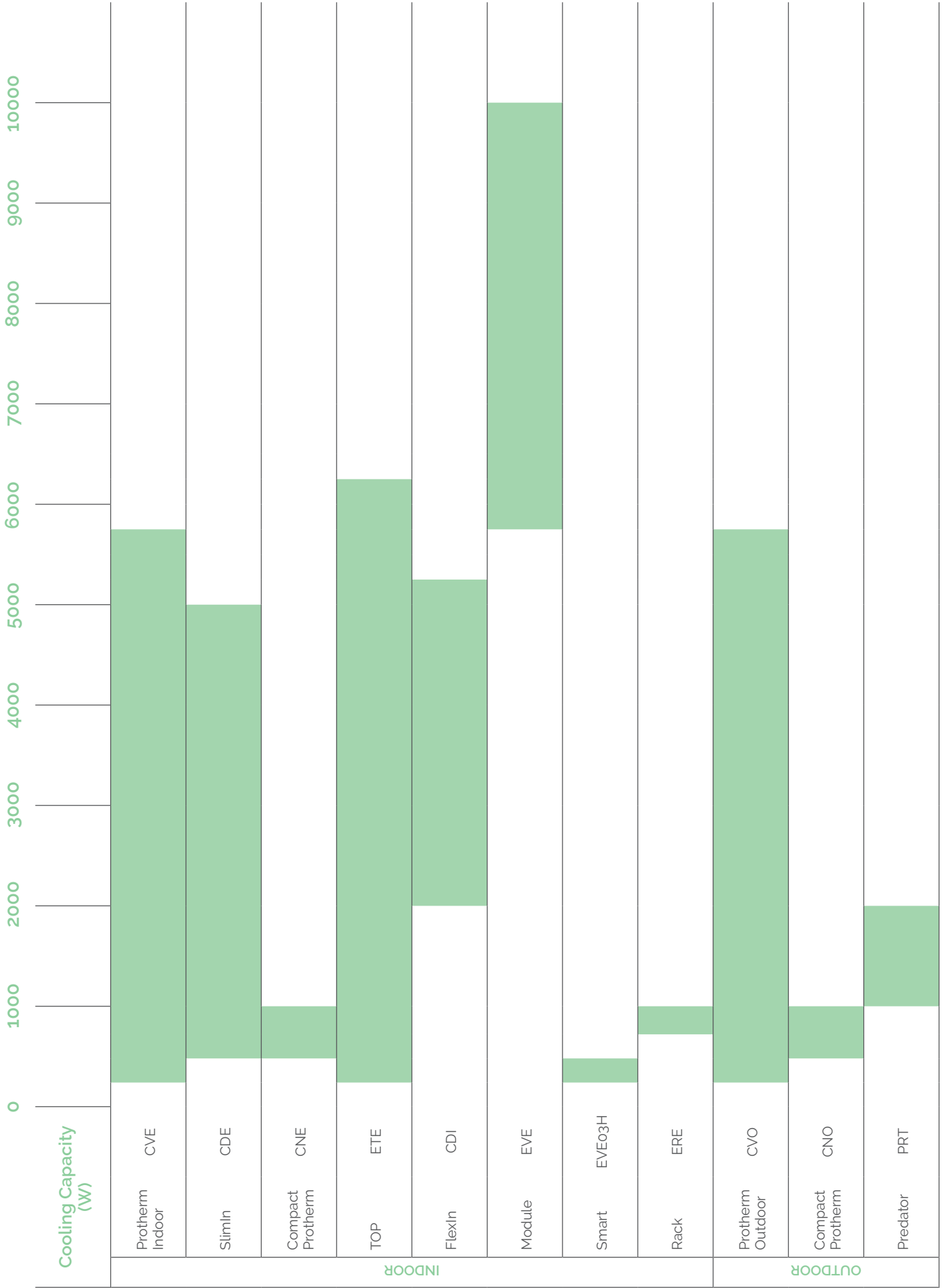

Condensate Evaporator

Device without any power consumption for the elimination or reduction of condensation produced by the air conditioner.

Operating principle: Condensate falls inside a container into which the compressor's hot tube is passed, evaporating the liquid. The vapour formed is transferred to the outside environment through the air flow of the condenser fan.



	CVE03	CVE05	CVE07	CVE08	CVE11	CVE15	CVE20	CVE25	CVE30	CVE40	CVE60
	CVO05	CVO08	CVO11	CVO15	CVO20	CVO40	CVO60				
	CDE05	CDE10	CDE14	CDE20	CDE30	CDE40					
	ETE03	ETE06	ETE09	ETE14	ETE20	ETE28	ETE41	ETE60			
	CNE04	CNE07	CNE10		CNO04	CNO07	CNO10		CDI20	CDI26	CDI40
	EVE60	EVE80	EVEA0		PRT10	PRT14	PRT20		EVE03H		ERE10

Legend



Present



Not available

Overview Air Conditioners Controllers

	CVE03	CVE05	CVE07	CVE08	CVE11	CVE15	CVE20	CVE25	CVE30	CVE40	CVE60
	TM	XCB + Display									
	CVO05	CVO08	CVO11	CVO15	CVO20	CVO40	CVO60				
	XCB + Display										
	CDE05	CDE10	CDE14	CDE20	CDE30	CDE40					
	XCB + Display										
	ETE03	ETE06	ETE09	ETE14	ETE20	ETE28	ETE41	ETE60			
	TM	TE									
	CNE04	CNE07	CNE10		CNO04	CNO07	CNO10		CDI20	CDI26	CDI40
	XCB + Display				XCB + Display				Scheda Inverter + Display		
	EVE60	EVE80	EVEA0		PRT10	PRT14	PRT20		EVE03H		ERE10
	TE				C100/C110 + Display				TM		TM

	TM	Mechanical Thermostat		XCB	Electronic Board XCB + Display
	TE	Electronic Thermostat		C100/110	Electronic Board C100/C110 + Display
				S Inverter	Inverter Electronic Board + Display

Mechanical Thermostat: gas-charged. It has a bulb positioned at the entry point of the air intake from the cabinet and detects and controls the temperature, giving consent to the devices connected to it.

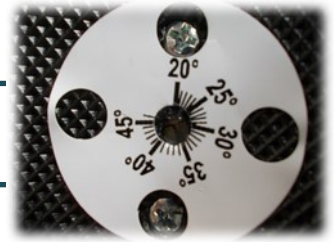

Electric Thermostat: microprocessor electronic controller for the management of the cooling function. Displays the operating statuses and any alarms and gives the possibility of modifying the user parameters. Presence of an alarm contact and remote control/open door



Electronic board XCB: installed in the internal compartment, offers adequate protection against external agents (dust, oils) in the environment. Mode of operation: direct expansion cooling and heating, for units equipped with electrical resistance



- Display of operating statuses and alarms and possibility of changing user parameters
- Presence of a changeover alarm contact (NO and NC) and a remote control/open door
- Test mode function for quick and easy component start-up and verification
- SEM and SEM2 functions for reducing power consumption by managing the evaporator fan
- Management of the condenser fan if the application requires low noise values
- Possibility of system redundancy via sequencing function and communication between two conditioners
- Elimination of hot spots with the possibility of installing a remote probe
- Remote communication via built-in RS485 serial port and Modbus RTU protocol

Electronic board C100/C110: installed in the internal compartment, offers adequate protection against external agents (dust, oil) in the environment



- Modes of operation: direct expansion cooling, Free Cooling, via modulation of the damper integrated in the air conditioner, emergency ventilation when the main power supply is not operating (if present), heating, for units equipped with an electric heater.
- Display of operating statuses and alarms and possibility of changing user parameters
- Signals: two alarm contacts, classified as warning and general, and two digital inputs to send remote or smoke-fire signals via external devices.
- Regulation: variable compressor speed 48Vdc (PRT20), condenser fan speed in relation to outside temperature in relation to the external operating temperature

Inverter Electronic Board: installed in the interior compartment, it offers adequate protection against external agents (dust, oils) in the environment

- Mode of operation: direct expansion cooling with continuous variation of the cooling capacity according to the actual heat load and optimising operation under all operating conditions.
- Display of operating statuses and alarms and possibility of changing user parameters
- Presence of a switch alarm contact (NO and NC) and a remote control/open door
- Test mode function for quick and easy component start-up and verification
- Intake or outlet internal temperature reading
- Elimination of hot spots with the possibility of installing a remote probe
- Temperature control with 0.2°C accuracy under stable load conditions
- Possibility of system redundancy via sequencing function and communication between three conditioners
- Remote communication via built-in Ethernet port and HTTP, SNMP, and TCP-IP protocols

Industrial Heat Exchangers

Characteristics of different types of heat exchangers for industrial applications

Water/Air Heat Exchangers

Using water as the cooling medium, water/air heat exchangers can provide **high cooling capacities** in relatively **small sizes**. They have a higher cooling capacity for the same size of an air conditioner and high savings can be achieved if several units are connected to an industrial chiller.

Water/air exchangers are recommended if:

- the outside air has a higher temperature value than the inside air
- the ambient air is extremely oily or dusty
- outside air and humidity must not enter the cabinet
- no heat is released into the environment
- cold/chilled water is available

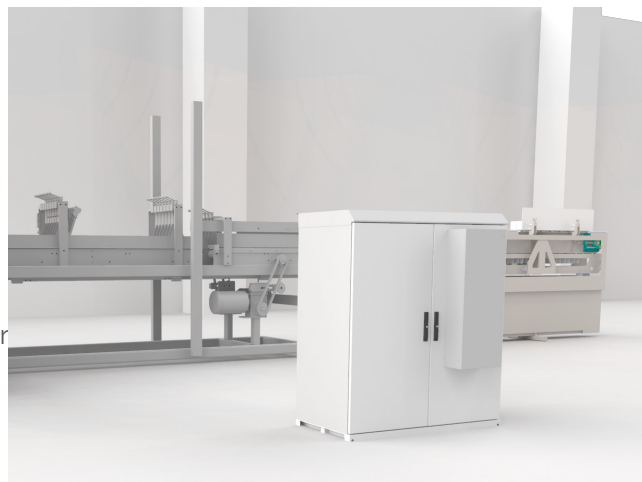

Air/Air Heat Exchangers

By exploiting the heat exchange between two separate air flows through an aluminium pack, air/air exchangers allow **heat to be dissipated** inside electrical panels with low maintenance and small dimensions. They are recommended if:

- the outside air has a lower temperature value than the inside air (approx. $\Delta T=10^{\circ}\text{C}$)
- a low cooling capacity is required
- little maintenance is required
- the ambient air is excessively oily or dusty
- outside air and humidity cannot enter the cabinet

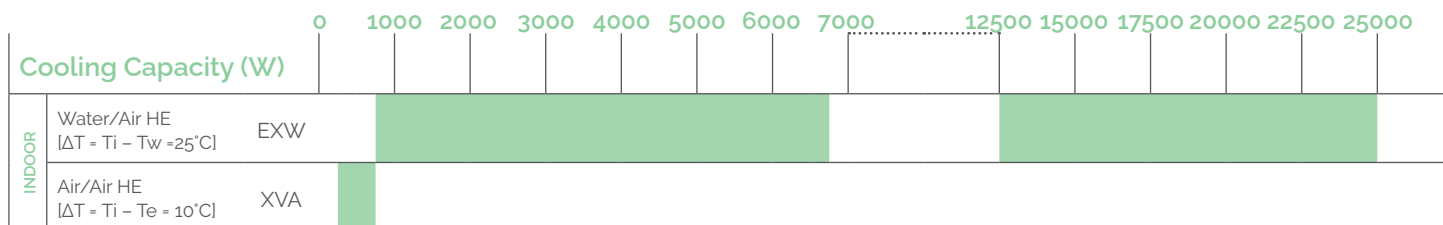

EXW

Wall and Roof (EXWxx0H) mounted Water/Air Heat Exchangers

Application: Indoor

Page 56



XVA

Air/Air Heat exchangers

Application: Indoor

Page 61

Industrial Ventilation for electrical panels

Features of ventilation systems for the electrical panel

Wall and Roof Filter fans for electrical panels

A wall-mounted or roof-mounted fan draws in cold ambient air or exhausts warm air from the electrical panel. They provide simple and economical heat dissipation and offer a compact and efficient solution.

They are recommended if:

- the outside air has a lower temperature value than the inside air (approx. $\Delta T=10^{\circ}\text{C}$)
- a low cooling capacity is required
- little maintenance is required
- the ambient air is not excessively oily or dusty
- outside air and humidity can enter the cabinet

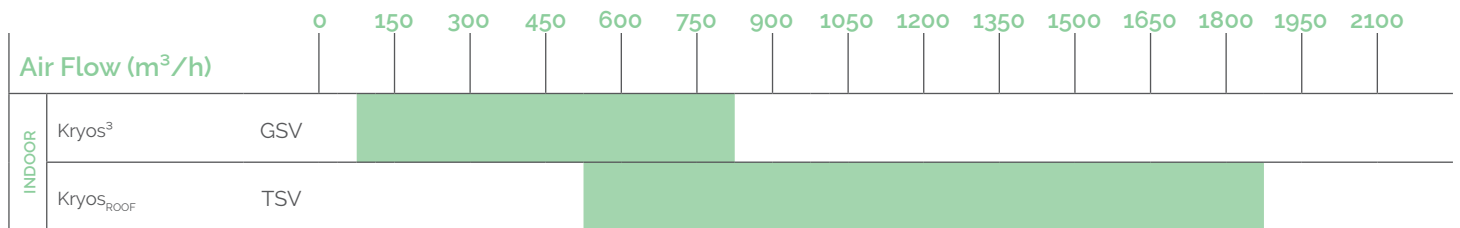

Kryos³

Filter fans for electrical panels

Application: Indoor

Page 65



KryosROOF

Roof mounted fans for electrical panels

Application: Indoor

Page 70

Products Certifications

In a globalised and competitive market it is essential to provide the correct certification required in each country to which the product is exported.

Having the CE mark is not sufficient for export in USA, Canada and the Eurasian countries. To this end, Cosmotec products have **specific certifications** which guarantee **high safety and quality standards**, adding brand value and **reducing type-approval and installation costs** along with the time required to enter the market



CE Certification: certifies that the product meets EU safety requirements



Certification UKCA: a conformity mark that indicates conformity with the applicable requirements for products sold within Great Britain



UL Listed Certification: certifies that the product complies with UL requirements and is related to the finished product and complete components, saving time and money on subsequent approvals of the electrical panel



UL Recognized Certification: certifies that the product complies with the requirements of UL, but is related to components that form the basic elements of larger products or systems



UL Listed FTTA Certification: Certification allows products to be installed without any further assessment regarding the Type protection approval process



CSA Certification: The Canadian Standard Association is the Canadian counterpart of the US body UL. It acts as a certification body for the compliance of safety components with Canadian standards



EAC Certification: Attestation certifying the conformity of a product to the requirements established by one or more Technical Regulations of the Customs Union, consisting of Russia, Belarus and Kazakhstan

	Declaration of Conformity EU + UKCA	Certificate of Compliance UL	Certificate of Compliance UL	Certificate of Compliance UL FTTA	Certificate of Compliance CSA	Certificate EAC
						
Protherm III CVE/CVO	✓	✓				✓
Compact Protherm CNE/CNO	✓	✓				✓
SlimIn III CDE	✓	✓				✓
FlexIn CDI	✓	✓				✓
Top II ETE	✓		✓			✓
Smart EVE	✓					✓
Module EVE	✓					✓
Rack ERE	✓					✓
Predator PRT	✓					✓
EXW	✓	✓				
XVA	✓	✓				
Kryos3 GS	✓		✓	✓	✓	✓
KryosROOF TS	✓		✓	✓		✓

Protherm - Indoor & Outdoor

Target: Savings and Efficiency

The increasing need to reduce consumption has forced the development of industrial air conditioning systems strongly oriented to **maximum efficiency**, while maintaining **robustness**, **reliability** and **compactness**, all characteristics that can be found in Protherm air conditioners.

Protherm offer a wide range of air conditioners to meet different customer requirements, both for cooling of electrical panels for **industrial applications** (CVE) and for the air conditioning of shelters/cabinets for **telecommunications, power distribution, etc** (CVO).

The **CVE** air conditioners, **for indoor applications**, are characterised by a display installed on the panel for the visualisation of information (except CVE03) and by the condensate dissipator (from CVE11 and CVE07).

The **CVO** air conditioners, suitable **for outdoor applications**, are able to operate at **low external temperatures**, even below **-20°C**; moreover the display is supplied as an accessory, in order to avoid vandalism or modifications, and can be integrated with an electric resistance for the heating function, when necessary (from CVO11).

Energy efficiency at the core

SEM (Smart Energy Management) and SEM2 logics provide **energy savings of up to 23%**, combined with an increase in the cooling power of the air conditioner. Thanks to the micro-channel coil of the Protherm air conditioners, which is thinner than traditional coils, there is a **significant reduction in pressure drops** and a greater air flow rate on the condenser, with a consequent reduction in power consumption. Furthermore, thanks to the management of the evaporator fan by the XCB electronic control, it is possible to achieve a **significant reduction in power consumption**.

Main Features

- Cooling Capacity : 360-5600 W CVE / 500-4000W CVO
- CVE (07/15/25)00S semi-flush mounting option
- Electronic Board XCB + display (except CVE03 - display as accessory on CVO)
- Certifications: CE, UL Listed, EAC
- Sequencing and Modbus (with specific accessories)
- Condensate dissipator available starting from CVE11 and on CVE0700S
- Quick connections (CE version, except CVE03)
- µchannel condenser (from CVE/CVO11 + CVE0700S)
- General alarm and remote control contacts (except CVE03)
- NEMA 4/4x protection degree for CVO UL units
- Operation down to -40°C ambient temperature for CVO UL Listed units
- Protective treatment on the condenser, standard for CVO UL Listed units

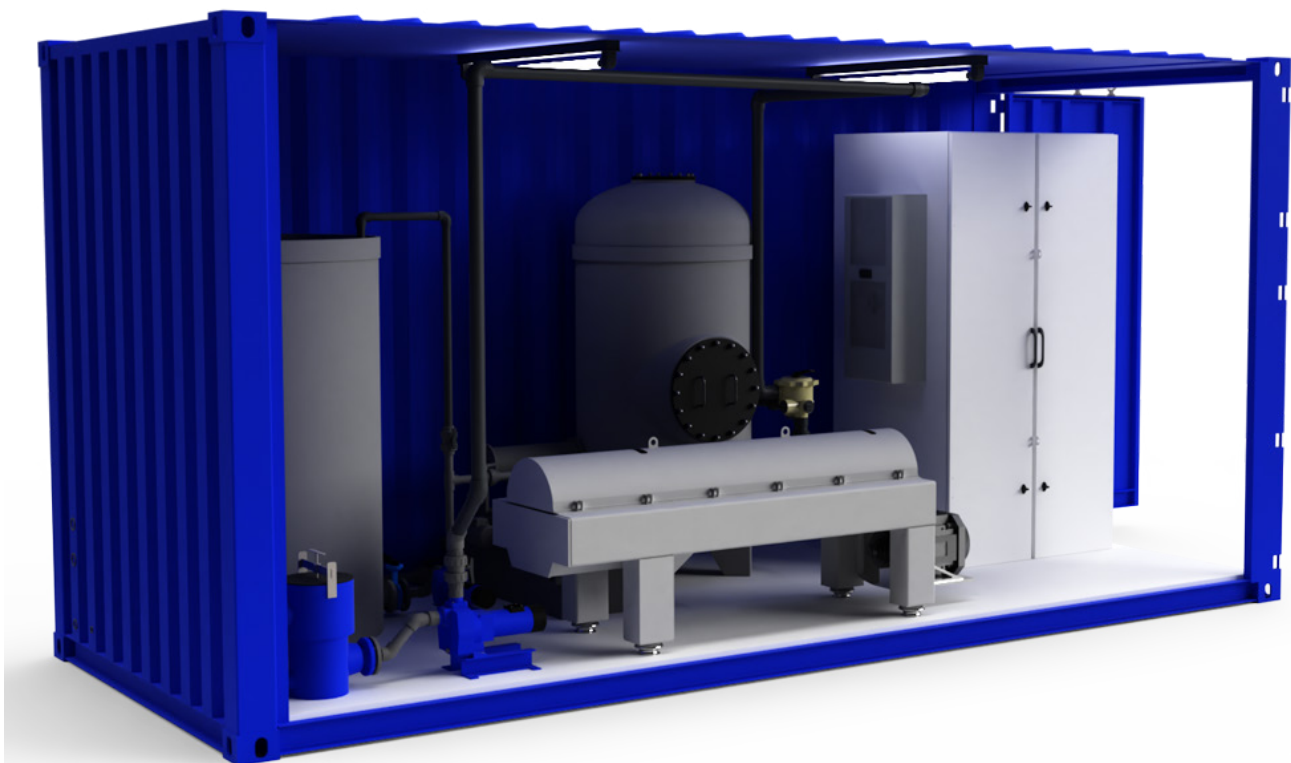

CVE03

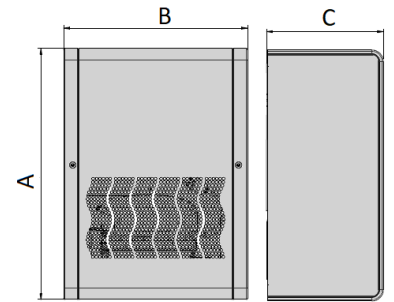
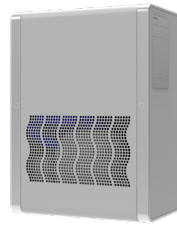

CODE	M.U.	CVE03002200000	CVE03U12200000	CVE03U12030000
UL Listed		--	✓	✓
Rated Voltage	V, ~	230, 1	230, 1	115, 1
Nominal Frequency	Hz	50 60	50 60	60
Cooling Capacity	L35L35 W	360 380	-- 380	380
Cooling Capacity	L35L50 W	220 240	-- 240	240
Power Consumption	L35L50 W	190 220	-- 220	220
Current Consumption	CE, L35L35 A	1,3 1,4	1,3 1,4	--
	UL, L45L55 A	--	-- 1,7	2,9
Start-up Current	CE A	9,8	9,8	--
Internal operating temperatures	min/max °C	+25 / +45	+25 / +45	+25 / +45
External operating temperatures	min/max °C	+20 / +55	+20 / +55	+20 / +55
Internal Circuit Protection Degree	CE IP	54	54	--
	UL Type	--	-- 12	12
External Sound Pressure	dB(A)	52	52	52
Height (A)	mm	443	443	443
Width (B)	mm	324,5	324,5	324,5
Depth (C)	mm	206	206	206
Weight	kg	17	17	17

CVE05

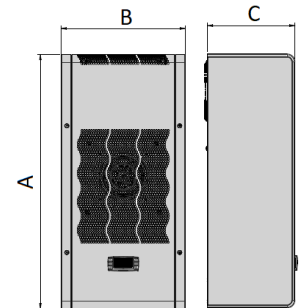
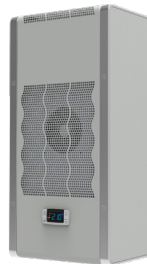

CODE	M.U.	CVE05002208000	CVE05002288000	CVE05U12208000	CVE05U12038000	CVE05002128000
UL Listed		--	--	✓	✓	--
Rated Voltage	V, ~	230, 1	400, 2 460, 2	230, 1	115, 1	48VDC
Nominal Frequency	Hz	50 60	50 60	50 60	60	--
Cooling Capacity	L35L35 W	550 580	500 550	-- 580	580	500
Cooling Capacity	L35L50 W	410 430	380 400	-- 430	430	350
Power Consumption	L35L50 W	320 390	320 390	-- 390	390	300
Current Consumption	CE, L35L35 A	1,4 1,6	0,8 0,9	1,4 1,5	--	5,7
	UL, L45L55 A	--	--	-- 21	4,7	--
Start-up Current	CE A	7,5	15	7,5	--	--
Internal operating temperatures	min/max °C	+25 / +45	+25 / +45	+25 / +45	+25 / +45	+25 / +35
External operating temperatures	min/max °C	+20 / +55	+20 / +55	+20 / +55	+20 / +55	+20 / +55
Internal Circuit Protection Degree	CE IP	54	54	54	--	54
	UL Type	--	--	-- 12	12	--
External Sound Pressure	dB(A)	60	60	60	60	64
Height (A)	mm	642	642	642	642	642
Width (B)	mm	314,5	314,5	314,5	314,5	314,5
Depth (C)	mm	221	221	221	221	221
Weight	kg	17	17	23	23	23

CVEo7S

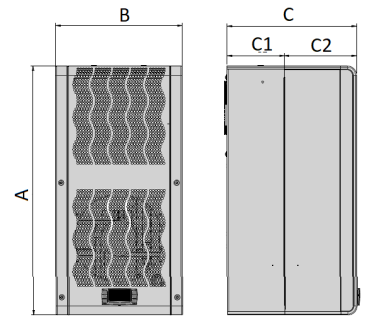
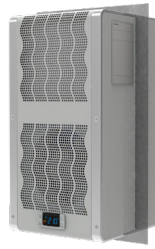

CODE	M.U.	CVEo700S208000	
UL Listed		--	
Rated Voltage	V, ~	230, 1	
Nominal Frequency	Hz	50	60
Cooling Capacity	L35L35 W	800	850
Cooling Capacity	L35L50 W	540	580
Power Consumption	L35L50 W	450	490
Current Consumption	CE, L35L35 A	1,9	2
	UL, L45L55 A	--	
Start.-up Current	CE A	9,6	
Internal operating temperatures	min/max °C	+25 / +45	
External operating temperatures	min/max °C	+20 / +55	
Internal Circuit Protection Degree	CE IP	54	
	UL Type	--	
External Sound Pressure	dB(A)	58	
Height (A)	mm	550	
Width (B)	mm	279	
Depth (C)	mm	286	
Weight	kg	20	

CVEo8

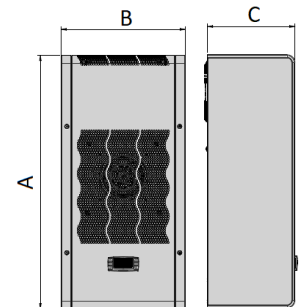
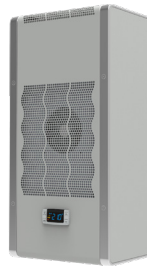

CODE	M.U.	CVEo8002208000		CVEo8002288000		CVEo8U12208000		CVEo8U12038000	
UL Listed		--		--		✓		✓	
Rated Voltage	V, ~	230, 1		400, 2 460, 2		230, 1		115, 1	
Nominal Frequency	Hz	50	60	50	60	50	60	60	
Cooling Capacity	L35L35 W	850	900	800	850	--	900	900	
Cooling Capacity	L35L50 W	620	700	600	650	--	700	700	
Power Consumption	L35L50 W	420	600	420	600	--	600	600	
Current Consumption	CE, L35L35 A	2,6	2,7	1	1,4	2,6	2,7	--	
	UL, L45L55 A	--		--		--	3,9	7,2	
Start.-up Current	CE A	20		20		20		--	
Internal operating temperatures	min/max °C	+25 / +45		+25 / +45		+25 / +45		+25 / +45	
External operating temperatures	min/max °C	+20 / +55		+20 / +55		+20 / +55		+20 / +55	
Internal Circuit Protection Degree	CE IP	54		54		54		--	
	UL Type	--		--		--	12	12	
External Sound Pressure	dB(A)	64		64		64		64	
Height (A)	mm	642		642		642		642	
Width (B)	mm	314,5		314,5		314,5		314,5	
Depth (C)	mm	221		221		221		221	
Weight	kg	27		30		27		27	

CVE11

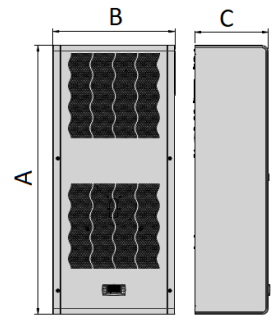
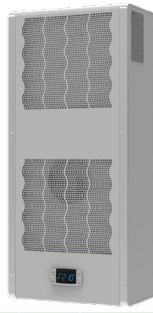

CODE	M.U.	CVE11002208000	CVE11002288000	CVE11U12208000	CVE11U12038000
UL Listed		--	--	✓	✓
Rated Voltage	V, ~	230, 1	400, 2 460, 2	230, 1	115, 1
Nominal Frequency	Hz	50 60	50 60	50 60	60
Cooling Capacity	L35L35 W	1100 1150	1050 1100	-- 1150	1150
Cooling Capacity	L35L50 W	840 890	790 840	-- 890	890
Power Consumption	L35L50 W	510 650	510 650	-- 650	650
Current Consumption	CE, L35L35 A	2,5 3	1,3 1,4	2,5 3	--
	UL, L45L55 A	--	--	-- 3,6	7,5
Start-up Current	CE A	20	40	20	--
Internal operating temperatures	min/max °C	+25 / +45	+25 / +45	+25 / +45	+25 / +45
External operating temperatures	min/max °C	+20 / +55	+20 / +55	+20 / +55	+20 / +55
Internal Circuit Protection Degree	CE IP	54	54	54	--
	UL Type	--	--	-- 12	12
External Sound Pressure	dB(A)	65	65	65	65
Height (A)	mm	913	913	913	913
Width (B)	mm	413	413	413	413
Depth (C)	mm	248	248	248	248
Weight	kg	44	50	44	44

CVE15

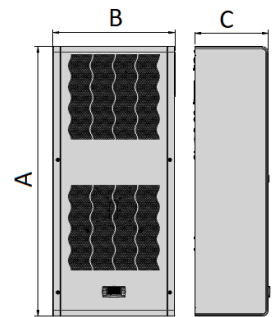
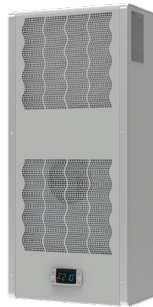

CODE	M.U.	CVE15002208000	CVE15002288000	CVE15U12208000	CVE15U12038000	CVE15U12628000
UL Listed		--	--	✓	✓	✓
Rated Voltage	V, ~	230, 1	400, 2 460, 2	230, 1	115, 1	400, 3 460, 3
Nominal Frequency	Hz	50 60	50 60	50 60	60	50 60
Cooling Capacity	L35L35 W	1500 1600	1400 1500	-- 1600	1600	-- 1500
Cooling Capacity	L35L50 W	1200 1280	1150 1200	-- 1280	1280	-- 1200
Power Consumption	L35L50 W	750 825	750 825	-- 825	825	-- 830
Current Consumption	CE, L35L35 A	3,9 4,3	2,5 2,6	3,9 4,3	--	2,4 1,5
	UL, L45L55 A	--	--	-- 4,5	8,6 L40L50	-- 1,97
Start-up Current	CE A	28	110	28	--	31
Internal operating temperatures	min/max °C	+25 / +45	+25 / +45	+25 / +45	+25 / +40	+25 / +45
External operating temperatures	min/max °C	+20 / +55	+20 / +55	+20 / +55	+20 / +50	+20 / +55
Internal Circuit Protection Degree	CE IP	54	54	54	--	54
	UL Type	--	--	-- 12	12	-- 12
External Sound Pressure	dB(A)	65	65	65	65	65
Height (A)	mm	913	913	913	913	1005
Width (B)	mm	413	413	413	413	413
Depth (C)	mm	248	248	248	248	263
Weight	kg	46	53	46	46	48

CVE15S

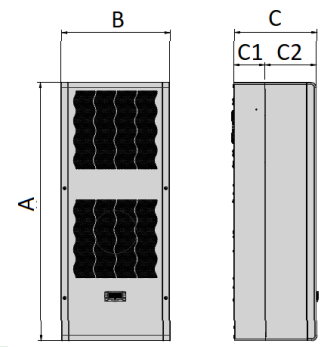
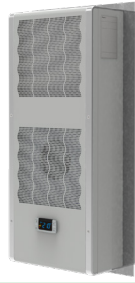

CODE	M.U.	CVE1500S208000		CVE1500S618000	
UL Listed		--		--	
Rated Voltage	V, ~	230, 1		400, 3	460, 3
Nominal Frequency	Hz	50	60	50	60
Cooling Capacity	L35L35 W	1500	1600	1400	1500
Cooling Capacity	L35L50 W	1200	1280	1150	1200
Power Consumption	L35L50 W	700	890	700	830
Current Consumption	CE, L35L35 A	4,2	4,8	1,5	1,4
	UL, L45L55 A	--	--	--	--
Start-up Current	CE A	28		31	
Internal operating temperatures	min/max °C	+25 / +45		+25 / +45	
External operating temperatures	min/max °C	+20 / +55		+20 / +55	
Internal Circuit Protection Degree	CE IP	54		54	
	UL Type	--		--	
External Sound Pressure	dB(A)	65		65	
Height (A)	mm	950		950	
Width (B)	mm	400		400	
Depth (C)	mm	304		304	
Weight	kg	47		47	

CVE20

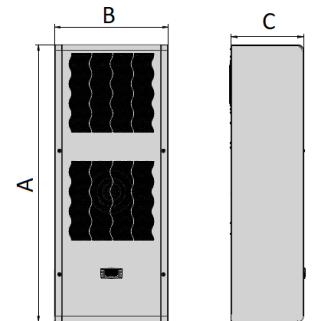
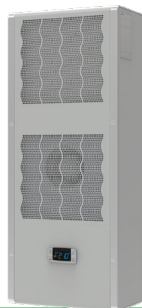

CODE	M.U.	CVE20002208000		CVE20002618000		CVE20U12208000		CVE20U12038000		CVE20U12628000	
UL Listed		--		--		✓		✓		✓	
Rated Voltage	V, ~	230, 1		400, 3	460, 3	230, 1		115, 1	400, 3	460, 3	
Nominal Frequency	Hz	50	60	50	60	50	60	60	50	60	
Cooling Capacity	L35L35 W	2100	2200	2000	2100	--	2200	2200	--	2100	
Cooling Capacity	L35L50 W	1750	1850	1700	1800	--	1850	1850	--	1800	
Power Consumption	L35L50 W	1120	1240	900	1100	--	1240	1240	--	1100	
Current Consumption	CE, L35L35 A	4,8	5,5	1,7	1,8	4,8	5,5	--	1,7	1,8	
	UL, L45L55 A	--	--	--	--	--	6,3	13,64	--	2,88	
Start-up Current	CE A	34		40		34		--		40	
Internal operating temperatures	min/max °C	+25 / +45		+25 / +45		+25 / +45		+25 / +45		+25 / +45	
External operating temperatures	min/max °C	+20 / +55		+20 / +55		+20 / +55		+20 / +55		+20 / +55	
Internal Circuit Protection Degree	CE IP	54		54		54		--		54	
	UL Type	--		--		--		12	12	--	
External Sound Pressure	dB(A)	66		66		66		66		66	
Height (A)	mm	1005		1005		1005		1005		1005	
Width (B)	mm	413		413		413		413		413	
Depth (C)	mm	263		263		263		263		263	
Weight	kg	48		48		48		48		48	

CVE25S

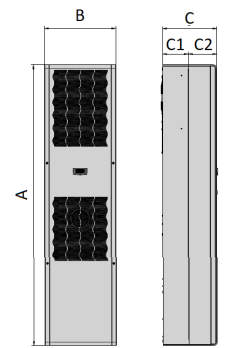

CODE	M.U.	CVE2500S208000		CVE2500S618000	
UL Listed		--	--	--	--
Rated Voltage	V, ~	230, 1	400, 3	460, 3	
Nominal Frequency	Hz	50	60	50	60
Cooling Capacity	L35L35 W	2550	2750	2400	2600
Cooling Capacity	L35L50 W	2000	2200	1900	2100
Power Consumption	L35L50 W	1050	1300	1050	1290
Current Consumption	CE, L35L35 A	3,9	5	1,8	2,1
	UL, L45L55 A	--	--	--	--
Start-up Current	CE A	36		31	
Internal operating temperatures	min/max °C	+25 / +45		+25 / +45	
External operating temperatures	min/max °C	+20 / +55		+20 / +55	
Internal Circuit Protection Degree	CE IP	54		54	
	UL Type	--		--	
External Sound Pressure	dB(A)	69		69	
Height (A)	mm	1580		1580	
Width (B)	mm	400		400	
Depth (C)	mm	305		305	
Weight	kg	65		68	

CVE30

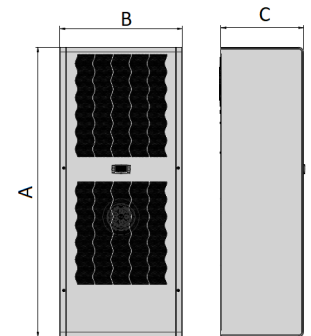

CODE	M.U.	CVE30002208000		CVE30002618000		CVE30U12208000		CVE30U12628000	
UL Listed		--	--	✓	✓	✓	✓	✓	✓
Rated Voltage	V, ~	230, 1	400, 3	460, 3	230, 1	400, 3	460, 3		
Nominal Frequency	Hz	50	60	50	60	50	60	50	60
Cooling Capacity	L35L35 W	3000	3150	2850	3000	--	3150	--	3000
Cooling Capacity	L35L50 W	2400	2600	2300	2500	--	2600	--	2500
Power Consumption	L35L50 W	1100	1370	1330	1590	--	1370	--	1590
Current Consumption	CE, L35L35 A	5	6,2	2,7	2,6	5	6,2	2,7	2,6
	UL, L45L55 A	--	--	--	--	--	8	--	4,55
Start-up Current	CE A	36		62		36		62	
Internal operating temperatures	min/max °C	+25 / +45		+25 / +45		+25 / +45		+25 / +45	
External operating temperatures	min/max °C	+20 / +55		+20 / +55		+20 / +55		+20 / +55	
Internal Circuit Protection Degree	CE IP	54		54		54		54	
	UL Type	--		--		--	12	--	12
External Sound Pressure	dB(A)	67		67		67		67	
Height (A)	mm	1219		1219		1219		1219	
Width (B)	mm	514		514		514		514	
Depth (C)	mm	347		347		347		347	
Weight	kg	75		80		75		80	

CVE40

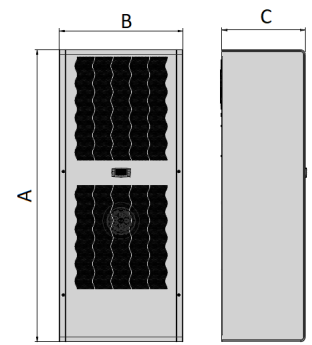

CODE	M.U.	CVE40002208000	CVE40002618000	CVE40U12208000	CVE40U12628000
UL Listed		--	--	✓	✓
Rated Voltage	V, ~	230, 1	400, 3 460, 3	230, 1	400, 3 460, 3
Nominal Frequency	Hz	50 60	50 60	50 60	50 60
Cooling Capacity	L35L35 W	4000 4100	3950 4050	-- 4100	-- 4050
Cooling Capacity	L35L50 W	3000 3300	2960 3260	-- 3300	-- 3260
Power Consumption	L35L50 W	1730 1950	1730 1950	-- 1850	-- 1840
Current Consumption	CE, L35L35 A	8,2 9,4	2,9 4	7,3 7,3	3,1 3,1
	UL, L45L55 A	--	--	-- 8,3	-- 5,26
Start-up Current	CE A	42	25	36	62
Internal operating temperatures	min/max °C	+25 / +45	+25 / +45	+25 / +45	+25 / +45
External operating temperatures	min/max °C	+20 / +55	+20 / +55	+20 / +55	+20 / +55
Internal Circuit Protection Degree	CE IP	54	54	54	54
	UL Type	--	--	-- 12	-- 12
External Sound Pressure	dB(A)	67	67	67	67
Height (A)	mm	1219	1219	1219	1219
Width (B)	mm	514	514	514	514
Depth (C)	mm	347	347	347	347
Weight	kg	80	85	80	85

CVE60

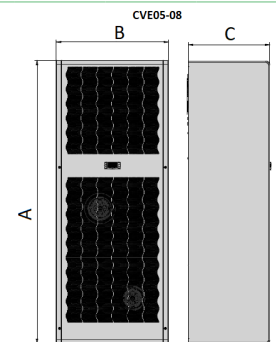
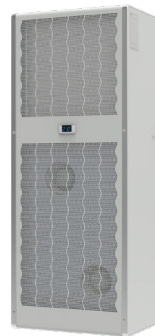

CODE	M.U.	CVE60002618000	CVE60U12628000
UL Listed		--	✓
Rated Voltage	V, ~	400, 3 460, 3	400, 3 460, 3
Nominal Frequency	Hz	50 60	50 60
Cooling Capacity	L35L35 W	5600 5950	-- 5950
Cooling Capacity	L35L50 W	4550 4850	-- 4850
Power Consumption	L35L50 W	2670 3600	-- 3600
Current Consumption	CE, L35L35 A	4,2 5,7	4,2 5,7
	UL, L45L55 A	--	-- 9,64
Start-up Current	CE A	53	53
Internal operating temperatures	min/max °C	+25 / +45	+25 / +45
External operating temperatures	min/max °C	+20 / +55	+20 / +55
Internal Circuit Protection Degree	CE IP	54	54
	UL Type	--	-- 12
External Sound Pressure	dB(A)	71	71
Height (A)	mm	1406	1406
Width (B)	mm	556	556
Depth (C)	mm	403	403
Weight	kg	100	100

Optional Protherm Indoor CVE

CODE	Special Colour	Stainless Steel AISI304 Housing	Stainless Steel AISI316 Housing	LN Version (only for 230 V units)	Control Phase Module (only for ~3 units)	Condenser Protective Treatment
CVE03	OCASC03	OCAINI0403	OCAINI1603	--	--	OCATC03
CVE05	OCASC05	OCAINI0405	OCAINI1605	OCALN05	--	OCATC05
CVE0700S	OCASC05	--	--	--	--	--
CVE08	OCASC05	OCAINI0405	OCAINI1605	OCALN08	--	OCATC05
CVE11	OCASC05	OCAINI0411	OCAINI1611	OCALN08	--	OCATC11
CVE15	OCASC05	OCAINI0411	OCAINI1611	OCALN08	OCACFM	OCATC11
CVE1500S	OCASC05	--	--	OCALNS15	OCACFM	--
CVE20	OCASC05	OCAINI0411	OCAINI1611	OCALN20	OCACFM	OCATC11
CVE2500S	OCASC30	--	--	OCALNS25	OCACFM	--
CVE30	OCASC30	OCAINI0430	OCAINI1630	OCALN20	OCACFM	--
CVE40	OCASC30	OCAINI0430	OCAINI1630	OCALN40	OCACFM	OCATC40
CVE60	OCASC60	OCAINI0460	OCAINI1660	OCALN60	OCACFM	OCATC40

Accessories Protherm Indoor CVE

CODE	Air filter (only for painted version)	Baffle	Semi-flush Mounting Frame	Flush Mounting Frame	IP55 Gasket (only for CE units)	Sequencing Cable	Modbus Serial Port	SE ² Remote Probe
CVE03	--	ACABAF03	--	--	ACAG03	--	--	--
CVE05	ACAFLTI05	ACABAF05	ACASEF05	ACATEF05	ACAG03	ACASEQ	ACASPM	ACARES
CVE0700S	ACAFLTS07	--	--	--	ACAG03 (2)	ACASEQ	ACASPM	ACARES
CVE08	ACAFLTI05	ACABAF05	ACASEF05	ACATEF05	ACAG03	ACASEQ	ACASPM	ACARES
CVE11	ACAFLTI11	ACABAF11	ACASEF11	ACATEF11	ACAG11	ACASEQ	ACASPM	ACARES
CVE15	ACAFLTI11	ACABAF11	ACASEF11/20 (1)	ACATEF11/20 (1)	ACAG11	ACASEQ	ACASPM	ACARES
CVE1500S	ACAFLTS15	--	--	--	ACAG11 (2)	ACASEQ	ACASPM	ACARES
CVE20	ACAFLTI11	ACABAF11	ACASEF20	ACATEF20	ACAG11	ACASEQ	ACASPM	ACARES
CVE2500S	ACAFLTS25	--	--	--	ACAG11 (2)	ACASEQ	ACASPM	ACARES
CVE30	ACAFLTI30	ACABAF30	ACASEF30	ACATEF30	ACAG11	ACASEQ	ACASPM	ACARES
CVE40	ACAFLTI30	ACABAF30	ACASEF30	ACATEF30	ACAG11	ACASEQ	ACASPM	ACARES
CVE60	ACAFLTI60	ACABAF60	--	--	ACAG11	ACASEQ	ACASPM	ACARES

(1) Check the model

(2) Only for external mounting

Accessories Optionals Protherm Indoor CVE

Air Filter CODE	Special Colour	Semi-flush Mounting Frame CODE	Special Colour	Flush Mounting Frame CODE	Special Colour
ACAFLTI05	OCASCFLTI05	ACASEF05	OCASCSEF05	ACATEF05	OCASCTEF05
ACAFLTS07	OCASCFLTI05	ACASEF11	OCASCSEF05	ACATEF11	OCASCTEF05
ACAFLTI11	OCASCFLTI05	ACASEF20	OCASCSEF05	ACATEF20	OCASCTEF05
ACAFLTS15	OCASCFLTI05	ACASEF30	OCASCSEF30	ACATEF30	OCASCTEF30
ACAFLTS25	OCASCFLTI05				
ACAFLTI30	OCASCFLTI30				
ACAFLTI60	OCASCFLTI60				

CVO05

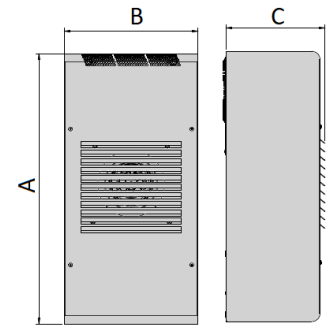

CODE	M.U.	CVO05002208000	CVO05002288000	CVO05U12208000	CVO05U12038000	CVO05002128000
UL Listed		--	--	✓	✓	--
Rated Voltage	V, ~	230, 1	400, 2 460, 2	230,1	115,1	48 VDC
Nominal Frequency	Hz	50 60	50 60	50 60	60	--
Cooling Capacity	L35L35 W	550 580	500 550	- 580	580	500
Cooling Capacity	L35L50 W	410 430	380 400	- 430	430	350
Power Consumption	L35L50 W	320 390	320 390	- 390	390	300
Current Consumption	CE, L35L35 A	1,4 1,6	0,8 0,9	1,4 1,5	-	5,7
	UL, L45L55 A	--	--	- 2,1	4,7	--
Start.-up Current	CE A	7,5	15	7,5	-	--
Internal operating temperatures	min/max °C	+25 / +45	+25 / +45	+25 / +45	+25 / +45	+25 / +35
External operating temperatures	min/max °C	-20 / +55	-20 / +55	-40 / +55	-40 / +55	-20 / +55
Internal Circuit Protection Degree	CE IP	54	54	55	-	54
	UL Type	--	--	- 4	4	--
External Sound Pressure	dB(A)	60	60	60	60	64
Height (A)	mm	636	636	636	636	636
Width (B)	mm	314,5	314,5	314,5	314,5	314,5
Depth (C)	mm	233	233	233	233	233
Weight	kg	23	26	23	23	23

CVO08

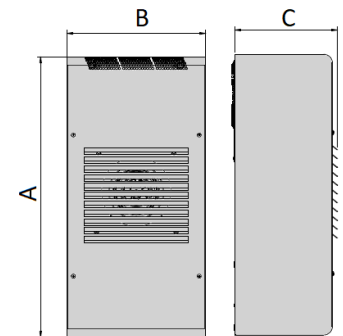

CODE	M.U.	CVO08002208000	CVO08002288000	CVO08U12208000	CVO08U12038000
UL Listed		--	--	✓	✓
Rated Voltage	V, ~	230,1	400, 2 460,2	230,1	115,1
Nominal Frequency	Hz	50 60	50 60	50 60	60
Cooling Capacity	L35L35 W	850 900	800 850	- 900	900
Cooling Capacity	L35L50 W	620 700	600 650	- 700	700
Power Consumption	L35L50 W	420 600	420 600	- 600	600
Current Consumption	CE L35L35 A	2,6 2,7	1 1,4	2,6 2,7	-
	UL L45L55 A	-	-	- 3,9	7,2
Start.-up Current	CE A	20	20	20	-
Internal operating temperatures	min/max °C	+25 / +45	+25 / +45	+25 / +45	+25 / +45
External operating temperatures	min/max °C	-20 / +55	-20 / +55	-40 / +55	-40 / +55
Internal Circuit Protection Degree	CE IP	54	54	55	-
	UL Type	-	-	- 4	4
External Sound Pressure	dB(A)	64	64	64	64
Height (A)	mm	636	636	636	636
Width (B)	mm	314,5	314,5	314,5	314,5
Depth (C)	mm	233	233	233	233
Weight	kg	27	30	27	27

CVO11

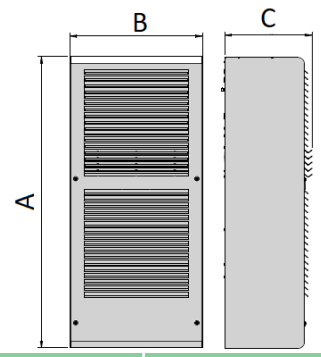

CODE	M.U.	CVO11002208000	CVO11002288000	CVO11U12208000	CVO11U12038000
UL Listed		--	--	✓	✓
Rated Voltage	V, ~	230,1	400, 2 460, 2	230,1	115,1
Nominal Frequency	Hz	50	60	50	60
Cooling Capacity	L35L35 W	1100	1150	1050	1100
Cooling Capacity	L35L50 W	840	890	790	840
Power Consumption	L35L50 W	510	650	510	650
Current Compsuntion	CE, L35L35 A	2,5	3	1,3	1,4
	UL, L45L55 A	-	--	-	3,6
Start.-up Current	CE A	20	40	20	-
Internal operating temperatures	min/max °C	+25 / +45	+25 / +45	+25 / +45	+25 / +45
External operating temperatures	min/max °C	-20 / +55	-20 / +55	-40 / +55	-40 / +55
Internal Circuit Protection Degree	CE IP	54	54	55	-
	UL Type	-	--	-	4
External Sound Pressure	dB(A)	65	65	65	65
Height (A)	mm	906	906	906	906
Width (B)	mm	412,5	412,5	412,5	412,5
Depth (C)	mm	271,5	271,5	271,5	271,5
Weight	kg	44	50	44	44

CVO15

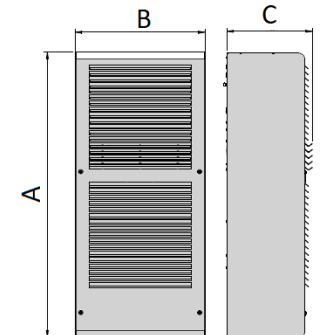

CODE	M.U.	CVO15002208000	CVO15002288000	CVO15U12208000	CVO15U12038000	CVO15U12628000
UL Listed		--	--	✓	✓	✓
Rated Voltage	V, ~	230,1	400, 2 460,2	230,1	115,1	400,3 460,3
Nominal Frequency	Hz	50	60	50	60	60
Cooling Capacity	L35L35 W	1500	1600	1400	1500	-
Cooling Capacity	L35L50 W	1200	1280	1150	1200	-
Power Consumption	L35L50 W	750	825	750	825	-
Current Compsuntion	CE, L35L35 A	3,9	4,3	2,5	2,6	3,9
	UL, L45L55 A	-	-	-	4,5	8,6 L40L50
Start.-up Current	CE A	28	110	28	--	31
Internal operating temperatures	min/max °C	+25 / +45	+25 / +45	+25 / +45	+25 / +40	+25 / +45
External operating temperatures	min/max °C	-20 / +55	-20 / +55	-40 / +55	-40 / +50	-40 / +55
Internal Circuit Protection Degree	CE IP	54	54	55	-	55
	UL Type	-	-	-	4	4
External Sound Pressure	dB(A)	65	65	65	65	65
Height (A)	mm	906	906	906	906	999
Width (B)	mm	412,5	412,5	412,5	412,5	412,5
Depth (C)	mm	271,5	271,5	271,5	271,5	286
Weight	kg	46	53	46	46	48

CVO20

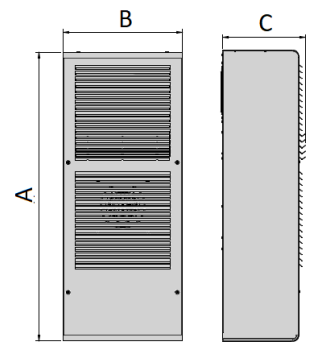

CODE	M.U.	CVO20002208000	CVO20002618000	CVO20U12208000	CVO20U12038000	CVO20U12628000
UL Listed		--	--	✓	✓	✓
Rated Voltage	V, ~	230, 1	400, 3 460,3	230,1	115,1	400,3 460,3
Nominal Frequency	Hz	50 60	50 60	50 60	60	50 60
Cooling Capacity	L35L35 W	2100 2200	2000 2100	- 2200	2200	- 2100
Cooling Capacity	L35L50 W	1750 1850	1700 1800	- 1850	1850	- 1800
Power Consumption	L35L50 W	1120 1240	1100 1200	- 1240	1240	- 1200
Current Compsuntion	CE L35L35 A	4,8 5,5	1,7 1,8	4,8 5,5	-	1,7 1,8
	UL L45L55 A	-	-	6,3	13,64	- 2,88
Start.-up Current	CE A	34	40	34	-	40
Internal operating temperatures	min/max °C	+25 / +45	+25 / +45	+25 / +45	+25 / +45	+25 / +45
External operating temperatures	min/max °C	-20 / +55	-20 / +55	-40 / +55	-40 / +55	-40 / +55
Internal Circuit Protection Degree	CE IP	54	54	55	-	55
	UL Type	-	- 4	- 4	4	- 4
External Sound Pressure	dB(A)	66	66	66	66	66
Height (A)	mm	999	999	999	999	999
Width (B)	mm	412,5	412,5	412,5	412,5	412,5
Depth (C)	mm	286	286	286	286	286
Weight	kg	48	48	48	48	48

CVO40

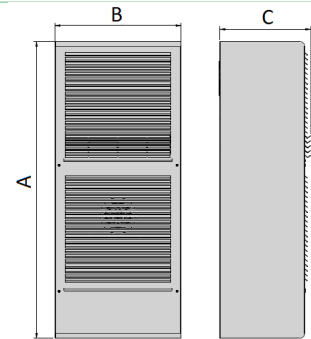

CODE	M.U.	CVO40002208000	CVO40002618000	CVO40U12208000	CVO40U12628000
UL Listed		--	--	✓	✓
Rated Voltage	V, ~	230,1	400,3 460,3	230,1	400,3 460,3
Nominal Frequency	Hz	50 60	50 60	50 60	50 60
Cooling Capacity	L35L35 W	4000 4100	3950 4050	- 4100	- 4050
Cooling Capacity	L35L50 W	3000 3300	2960 3260	- 3300	- 3260
Power Consumption	L35L50 W	1730 1950	1730 1950	- 1850	- 1840
Current Compsuntion	CE L35L35 A	8,2 9,4	2,9 4	2,3 7,3	3,1 3,1
	UL L45L55 A	-	-	8,3	- 5,26
Start.-up Current	CE A	42	25	36	62
Internal operating temperatures	min/max °C	+25 / +45	+25 / +45	+25 / +45	+25 / +45
External operating temperatures	min/max °C	-20 / +55	-20 / +55	-40 / +55	-40 / +55
Internal Circuit Protection Degree	CE IP	54	54	55	55
	UL Type	-	-	- 4	- 4
External Sound Pressure	dB(A)	67	67	67	67
Height (A)	mm	1211	1211	1211	1211
Width (B)	mm	514	514	514	514
Depth (C)	mm	370	370	370	370
Weight	kg	80	85	80	85

CVO60

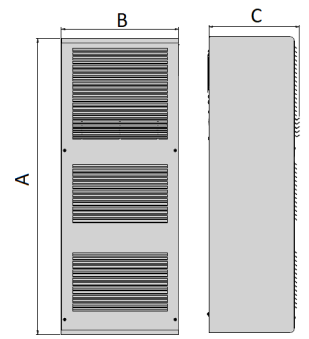

CODE	M.U.	CVO60002618000	CVO60U12628000
UL Listed		--	✓
Rated Voltage	V, ~	400,3	460,3
Nominal Frequency	Hz	50	60
Cooling Capacity	L35L35 W	5600	5950
Cooling Capacity	L35L50 W	4550	4850
Power Consumption	L35L50 W	2670	3600
Current Consumption	CE L35L35 A	4,2	5,7
	UL L45L55 A	-	9,46
Start-up Current	CE A	53	53
Internal operating temperatures	min/max °C	+25 / +45	+25 / +45
External operating temperatures	min/max °C	-20 / +55	-40 / +55
Internal Circuit Protection Degree	CE IP	54	55
	UL Type	-	4
External Sound Pressure	dB(A)	71	71
Height (A)	mm	1399	1399
Width (B)	mm	556	556
Depth (C)	mm	428	428
Weight	kg	100	100

Optional Protherm Outdoor CVO

CODE	Special Colour (only for CE units)	Stainless Steel AISI304 Housing	Stainless Steel AISI316 Housing	LN Version (only for 230V units)	Control Phase Module (only for three-phase units)	Condenser Protective Treatment	Electrical Heating (only for 230V units)
CVO05	OCASC05	OCAINO0405	OCAINO1605	OCALN05	--	OCATC05 (1)	--
CVO08	OCASC05	OCAINO0405	OCAINO1605	OCALN08	--	OCATC05 (1)	--
CVO11	OCASC05	OCAINO0411	OCAINO1611	OCALN08	--	OCATC11 (4)	RSC1
CVO15	OCASC05	OCAINO0411	OCAINO1611	OCALN08	OCACFM	OCATC11 (1)	RSC1
CVO20	OCASC05	OCAINO0411	OCAINO1611	OCALN20	OCACFM	OCATC11 (1)	RSC1
CVO40	OCASC30	OCAINO0430	OCAINO1630	OCALN40	OCACFM	OCATC40 (1)	RSC1-RSC3
CVO60	OCASC60	OCAINO0460	OCAINO1660	OCALN60	OCACFM	OCATC40 (1)	--

(1) Standard on UL Listed units

Accessories Protherm Outdoor CVO

CODICE	Filter	Keypad	Semi-flush Mounting Frame	Flush Mounting Frame	IP55 Gasket (only for CE units)	Sequencing Cable	Modbus Serial Port	SE ² Remote Probe
CVO05	ACAFLTO05	ACAKPD	ACASEF05	ACATEF05	ACAG03	ACASEQ	ACASPM	ACARES
CVO08	ACAFLTO05	ACAKPD	ACASEF05	ACATEF05	ACAG03	ACASEQ	ACASPM	ACARES
CVO11	ACAFLTO11	ACAKPD	ACASEF11	ACATEF11	ACAG11	ACASEQ	ACASPM	ACARES
CVO15	ACAFLTO11	ACAKPD	ACASEF11/20 (1)	ACATEF11/20 (1)	ACAG11	ACASEQ	ACASPM	ACARES
CVO20	ACAFLTO11	ACAKPD	ACASEF20	ACATEF20	ACAG11	ACASEQ	ACASPM	ACARES
CVO40	ACAFLTO30	ACAKPD	ACASEF30	ACATEF30	ACAG11	ACASEQ	ACASPM	ACARES
CVO60	ACAFLTO60	ACAKPD	--	--	ACAG11	ACASEQ	ACASPM	ACARES

(1) Check the model

Compact Protherm - Indoor & Outdoor

Complete and Compact Solution

Compact Protherm is the range of industrial air conditioners designed for installations where units with **small overall dimensions** in terms of width or height are required. The technical solutions available distinguish these compact air conditioners for electrical panels for **flexibility, reliability** and **efficiency**.

In industrial automation, production space is an increasingly valuable asset and there is a need to find solutions that combine **high performance** with **optimised layouts**. However, the optimisation of the space also generates a greater density of electronic control components, worsening the thermal conditions of the system, which must be protected even more carefully against overheating in order to guarantee **continuity of service**. Compact Protherm, an evolution of our bestseller, offers a Thermal Management solution suitable for placement on the side of all electrical cabinets **up to 300mm deep**, thanks to a **width of only 280mm**. In addition, the range also features a low height of 565mm, allowing it to be installed in electrical boxes integrated into machine tools.

This new range of air conditioners responds to the needs of sectors where attention to hygiene is essential, such as the Food & Beverage. The main features that make Compact Protherm perfect for this kind of application are: possibility of **stainless steel coating**, high **IP55/Type4/4x protection degree**, dedicated **layout and some** and a few accessories available, such as the **roof inclined at 30°**, which avoid the deposit of dust and liquids on the roof, meeting the requirements of hygiene and safety.

Main Features

- Application Indoor (CNE) and Outdoor (CNO)
- Compact dimensions - Two sizes , one cut-out
- Cooling Capacity: 400W...1000W
- High Efficiency
- Wide power supply range
- Certifications: CE, UL, EAC
- Protection Degree: IP54/55, Type12/4-4x
- Electronic Board (+display)
- Condensate Dissipatore (Indoor Version)
- Low noise
- Quick electric connections

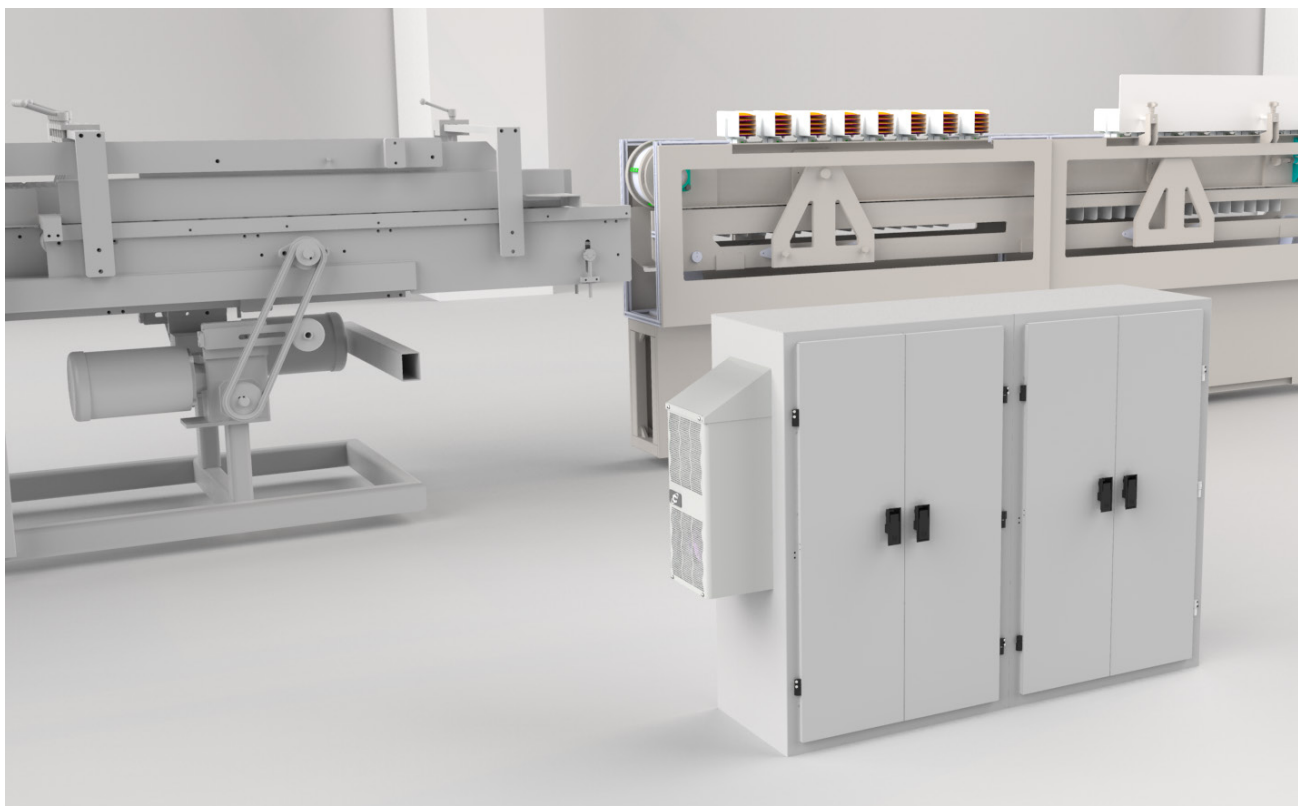

CNE04

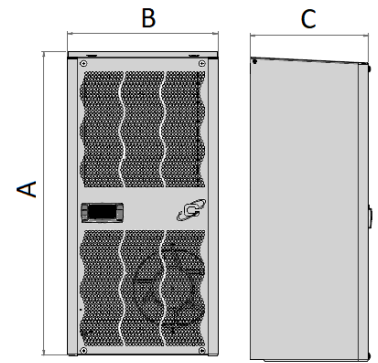

CODE	M.U.	CNE040022080000	CNE040022880000		CNE04U122080000		CNE04U122880000		CNE04U120380000	
UL LISTED		--	--		✓		✓		✓	
Rated Voltage	V, ~	230, 1	400,2	460,2	230, 1	400,2	460,2	115, 1		
Nominal Frequency	Hz	50	60	50	60	50	60	60		
Cooling Capacity	L35L35 W	455	495	450	490	--	495	--	490	455
Cooling Capacity	L35L50 W	340	385	335	380	--	385	--	380	335
Power Consumption	L35L50 W	205	220	205	220	--	220	--	220	255
Max current consumption.	A	1,2	1,1	0,6	0,55	1,2	1,25	0,6	---	2,49
Start-up current	CE A	4,6	2,6		4,6	2,6		--		
Internal operating temp..	min/max °C	+20 / +45	+20 / +45		+20 / +45	+20 / +45		+25 / +45		
External operating temp.	min/max °C	+20 / +55	+20 / +55		+20 / +55	+20 / +55		+20 / +50		
Protection Degree internal circuit	CE IP	54	54		54	54		--		
	UL Type	--	--		--	12	--	12	12	
External sound pressure	dB(A)	55	55		55	55		55		
Height (A)	mm	565	565		565	565		565		
Width (B)	mm	280	280		280	280		280		
Depth (C)	mm	220	278		220	278		220		
Weight	kg	17	21		17	21		17		

CNE07

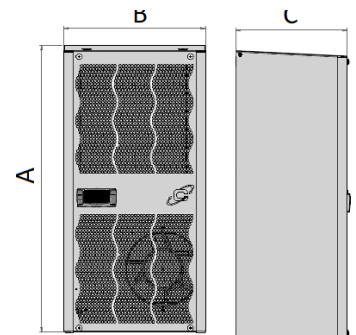

CODE	M.U.	CNE070022080000	CNE070022880000		CNE07U122080000		CNE07U122880000		CNE07U120380000	
UL LISTED		--	--		✓		✓		✓	
Rated Voltage	V, ~	230, 1	400,2	460,2	230, 1	400,2	460,2	115, 1		
Nominal Frequency	Hz	50	60	50	60	50	60	60		
Cooling Capacity	L35L35 W	660	670	645	655	--	670	--	655	625
Cooling Capacity	L35L50 W	450	490	440	480	--	490	--	480	460
Power Consumption	L35L50 W	350	360	350	360	--	360	--	360	335
Max current consumption.	A	2	1,6	1	0,8	2	1,59	1	---	3,21
Start-up current	CE A	7	4,5		7	4,5		--		
Internal operating temp..	min/max °C	+20 / +45	+20 / +45		+20 / +45	+20 / +45		+25 / +45		
External operating temp.	min/max °C	+20 / +55	+20 / +55		+20 / +55	+20 / +55		+20 / +50		
Protection Degree internal circuit	CE IP	54	54		54	54		--		
	UL Type	--	--		--	12	--	12	12	
External sound pressure	dB(A)	55	55		55	55		55		
Height (A)	mm	565	565		565	565		565		
Width (B)	mm	280	280		280	280		280		
Depth (C)	mm	220	278		220	278		220		
Weight	kg	18	22		18	22		18		

CNE10

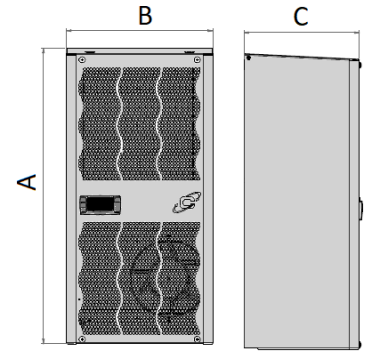

CODE	M.U.	CNE100022080000	CNE100022880000	CNE10U122080000	CNE10U122880000	CNE10U120380000
UL LISTED		--	--	✓	✓	✓
Rated Voltage	V, ~	230, 1	400,2 460,2	230, 1	400,2 460,2	115, 1
Nominal Frequency	Hz	50 60	50 60	50 60	50 60	60
Cooling Capacity	L35L35 W	975 1075	950 1050	-- 1075	-- 1050	950
Cooling Capacity	L35L50 W	750 830	745 825	-- 830	-- 825	700
Power Consumption	L35L50 W	480 530	480 530	-- 530	-- 530	555
Max current consumption.	A	2,5 2,8	1,4 1,4	2,5 2,4	1,4 ---	5,09
Start-up current	CE A	46	4,5	46	4,5	--
Internal operating temp..	min/max °C	+20 / +45	+20 / +45	+20 / +45	+20 / +45	+25 / +45
External operating temp.	min/max °C	+20 / +55	+20 / +55	+20 / +55	+20 / +55	+20 / +50
Protection Degree internal circuit	CE IP	54	54	54	54	--
	UL Type	--	--	-- 12	-- 12	12
External sound pressure	dB(A)	58	58	58	58	58
Height (A)	mm	565	565	565	565	565
Width (B)	mm	280	280	280	280	280
Depth (C)	mm	278	278	278	278	278
Weight	kg	20	23	20	23	20

CNO04

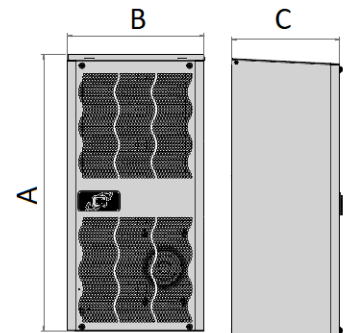
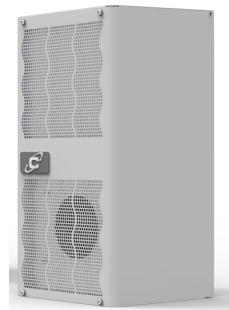

CODE	M.U.	CNO040022080000	CNO040022880000	CNO04U122080000	CNO04U122880000	CNO04U120380000
UL LISTED		--	--	✓	✓	✓
Rated Voltage	V, ~	230, 1	400,2 460,2	230, 1	400,2 460,2	115, 1
Nominal Frequency	Hz	50 60	50 60	50 60	50 60	60
Cooling Capacity	L35L35 W	455 495	450 490	-- 495	-- 490	455
Cooling Capacity	L35L50 W	340 385	335 380	-- 385	-- 380	335
Power Consumption	L35L50 W	205 220	205 220	-- 220	-- 220	255
Max current consumption.	A	1,2 1,1	0,6 0,55	1,2 1,25	0,6 ---	2,49
Start-up current	CE A	4,6	2,6	4,6	2,6	--
Internal operating temp..	min/max °C	+20 / +45	+20 / +45	+20 / +45	+20 / +45	+25 / +45
External operating temp.	min/max °C	-20 / +55	-20 / +55	-20 / +55	-20 / +55	-20 / +55
Protection Degree internal circuit	CE IP	54	54	55	55	--
	UL Type	--	--	-- 4	-- 4	4
External sound pressure	dB(A)	55	55	55	55	55
Height (A)	mm	565	565	565	565	565
Width (B)	mm	280	280	280	280	280
Depth (C)	mm	220	278	220	278	220
Weight	kg	17	21	17	21	17

CNO07

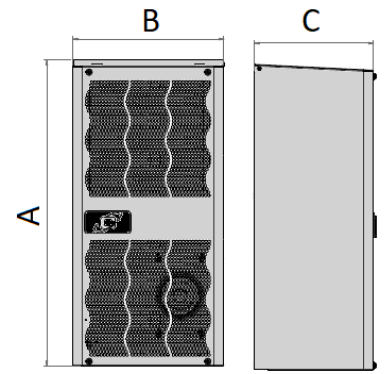
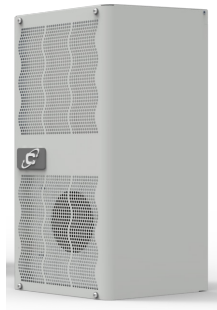

CODE	M.U.	CNO070022080000	CNO070022880000		CNO07U122080000		CNO07U122880000		CNO07U120380000
UL LISTED		--	--	--	✓	✓	✓	✓	✓
Rated Voltage	V, ~	230,1	400,2	460,2	230,1	400,2	460,2	115,1	
Nominal Frequency	Hz	50	60	50	60	50	60	50	60
Cooling Capacity	L35L35 W	660	670	645	655	--	670	--	655
Cooling Capacity	L35L50 W	450	490	440	480	--	490	--	480
Power Consumption	L35L50 W	350	360	350	360	--	360	--	360
Max current consumption.	A	2	1,6	1	0,8	2	1,59	1	---
Start-up current	CE A	7		4,5		7		4,5	--
Internal operating temp..	min/max °C	+20 / +45		+20 / +45		+20 / +45		+20 / +45	+25 / +45
External operating temp.	min/max °C	-20 / +55		-20 / +55		-20 / +55		-20 / +55	-20 / +55
Protection Degree internal circuit	CE IP	54		54		55		55	--
	UL Type	--		--		--	4	--	4
External sound pressure	dB(A)	55		55		55		55	55
Height (A)	mm	565		565		565		565	565
Width (B)	mm	280		280		280		280	280
Depth (C)	mm	278		278		278		278	278
Weight	kg	18		22		18		22	18

CNO10

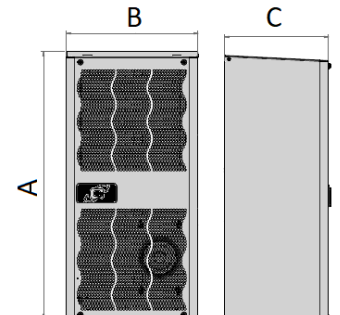
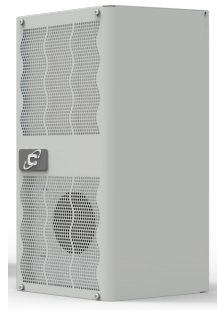

CODE	M.U.	CNO100022080000	CNO100022880000		CNO10U122080000		CNO10U122880000		CNO10U120380000
UL LISTED		--	--	--	✓	✓	✓	✓	✓
Rated Voltage	V, ~	230,1	400,2	460,2	230,1	400,2	460,2	115,1	
Nominal Frequency	Hz	50	60	50	60	50	60	50	60
Cooling Capacity	L35L35 W	975	1075	950	1050	--	1075	--	1050
Cooling Capacity	L35L50 W	750	830	745	825	--	830	--	825
Power Consumption	L35L50 W	480	530	480	530	--	530	--	530
Max current consumption.	A	2,5	2,8	1,4	1,4	2,5	2,4	1,4	---
Start-up current	CE A	46		4,5		46		4,5	--
Internal operating temp..	min/max °C	+20 / +45		+20 / +45		+20 / +45		+20 / +45	+25 / +45
External operating temp.	min/max °C	-20 / +55		-20 / +55		-20 / +55		-20 / +55	-20 / +55
Protection Degree internal circuit	CE IP	54		54		55		55	--
	UL Type	--		--		--	4	--	4
External sound pressure	dB(A)	58		58		58		58	58
Height (A)	mm	565		565		565		565	565
Width (B)	mm	280		280		280		280	280
Depth (C)	mm	278		278		278		278	278
Weight	kg	20		23		20		23	20

Optional Compact Protherm Indoor CNE

CODE	Special Colour	Stainless Steel AISI304 Housing	Stainless Steel AISI316 Housing	Remote Probe	Condenser Protective Treatment
CNE04	OCASCCP	OCAINI0404/10	OCAINI1604/10	OCARESCP	OCATC04
CNE07	OCASCCP	OCAINI0404/10	OCAINI1604/10	OCARESCP	OCATC07
CNE10	OCASCCP	OCAINI0410	OCAINI1610	OCARESCP	OCATC07

Accessories Compact Protherm Indoor CNE

CODE	Air Filter	Baffle	IP55 Gasket	Sequencing Cable	Modbus Serial Port	Rubber Caps	30° Sloped Roof
CNE04	ACAFLTI04 (1)	ACABAF04	ACAG03 (2)	ACASEQ	ACASPM	ACACAP	ACATOP04/10
CNE07	ACAFLTI04 (1)	ACABAF04	ACAG03 (2)	ACASEQ	ACASPM	ACACAP	ACATOP04/10
CNE10	ACAFLTI04 (1)	ACABAF10	ACAG03 (2)	ACASEQ	ACASPM	ACACAP	ACATOP10

(1) Available only for units in painted sheet metal

(2) Only for CE units

Option for Accessories Compact Protherm Indoor CNE

CODE	Special Colour	304 Stainless Steel housing	Stainless Steel 316 Housing
ACAFLTI04	OCASCFLTI04	---	---
ACATOP04	OCASCTOP04	OCAINI04T04	OCAINI16T04
ACATOP10	OCASCTOP10	OCAINI04T10	OCAINI16T10

Optional Compact Protherm Outdoor CNO

CODE	Special Colour (only for CE units)	Stainless Steel 304 housing	Stainless Steel 316 housing	Condenser protective treatment	Remote Probe	Electric Heating
CNO04	OCASCCP	OCAINI0404/10	OCAINI1604/10	OCATC04	OCARESCP (1)	RSC06 (2)
CNO07	OCASCCP	OCAINI0404/10	OCAINI1604/10	OCATC07	OCARESCP (1)	RSC06 (2)
CNO10	OCASCCP	OCAINI0410	OCAINI1610	OCATC07	OCARESCP (1)	RSC06 (2)

(1) Only with electrical heater

(2) Only for 230V-400V/460V tension

Accessories Compact Protherm Outdoor CNO

CODE	IP55 Gasket (only CE units)	Sequencing Cable	Modbus Serial Port	Keypad	Rubber Caps	30° Sloped Roof
CNO04	ACAG03 (1)	ACASEQ	ACASPM	ACAKPD	ACACAP	ACATOP04/10
CNO07	ACAG03 (1)	ACASEQ	ACASPM	ACAKPD	ACACAP	ACATOP04/10
CNO10	ACAG03 (1)	ACASEQ	ACASPM	ACAKPD	ACACAP	ACATOP10

Options for Accessories Compact Protherm Outdoor

CODE	Special Colour	Stainless Steel 304 housing	Stainless Steel 316 Housing
ACATOP04	OCASCTOP04	OCAINI04T04	OCAINI16T04
ACATOP10	OCASCTOP10	OCAINI04T10	OCAINI16T10

SlimIn - Indoor

Slim In CDE is the range of extra-flat air conditioners designed for external, semi-flush or flush mounting, ideal for installations requiring small overall dimensions and reduced protrusion from the panel. The characteristics of the unit allow easy and quick installation.

Efficiency at the forefront

Slim In has high EER values and consequent cost savings thanks to the use of:

- high performance compressors and fans
- micro-channel condenser, which with its reduced thickness allows better air flow
- energy saving functions (SEM and SEM2)



The SlimIn CDE range of air conditioners guarantees **considerable economic savings**, up to values of 50%, and time savings, thanks to the solutions adopted, which make the **installation** of the air conditioner and any **maintenance** activities **easier** and **quicker** to carry out.

Main Features

- High Efficiency
- Cooling Capacity: 500 - 4000 W
- XCB electronic board + display
- Installation: Flush, semi-flush, external mounting
- Quick electric connections
- Sequencing and Modbus
- μ channel condenser (from CDE14)
- Condensate Dissipator (from CDE14)
- General alarm and remote enable contacts
- Gasket already installed on the air conditioner
- Functioning up to +60°C external temperature
- Certifications: CE, UL Listed, EAC

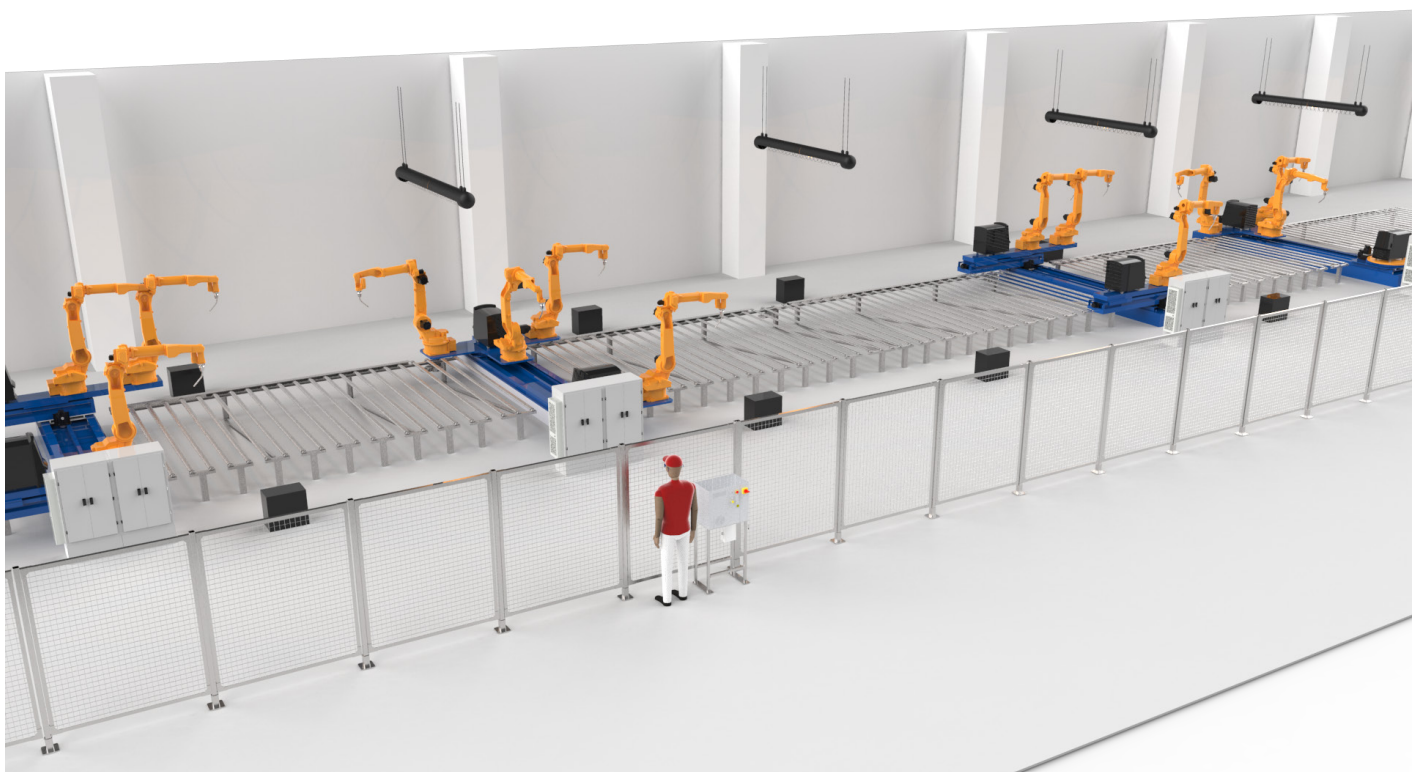

CDE05

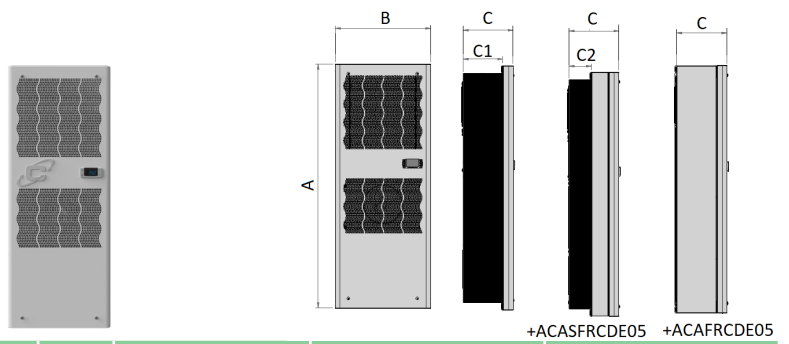

+ACASFR CDE05 +ACAFRCDE05

CODE	M.U.	CDE05U320380000	CDE05A322080000	CDE05U322080000
UL LISTED		✓	--	✓
Rated Voltage	V, ~	115,1	230,1	230,1
Nominal Frequency	Hz	60	50	60
Cooling Capacity	L35L35 W	575	600	670
Cooling Capacity	L35L50 W	425	510	540
Power Consumption	L35L50 W	350	380	425
Max current consumption.	A	4	2,3 (2,4 60°C)	2,4
Start-up current	CE A	--	7,5	7,5
Internal operating temp..	min/max °C	25/45	25/45	25/45
External operating temp.	min/max °C	20/55	20/60	20/55
Protection Degree internal circuit	CE IP	--	54	54
	UL Type	12	--	12
External sound pressure	dB(A)	54	54	54
Height (A)	mm	956	956	956
Width (B)	mm	375	375	375
Depth (C - C1 - C2)	mm	196 - 155 - 89	196 - 155 - 89	196 - 155 - 89
Weight	kg	30	30	30

CDE10

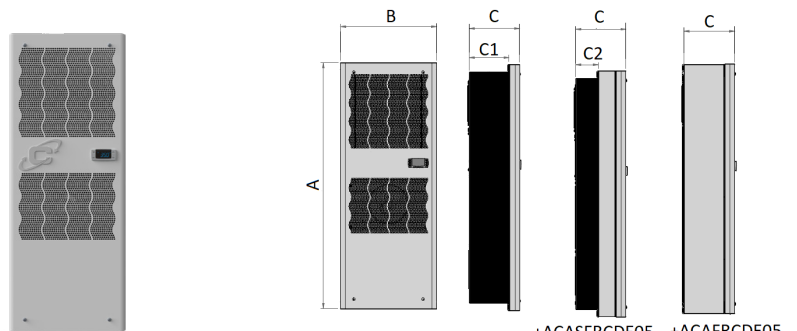

+ACASFR CDE05 +ACAFRCDE05

CODE	M.U.	CDE10U320380000	CDE10A322080000	CDE10U322080000
UL LISTED		✓	--	✓
Rated Voltage	V, ~	115,1	230,1	230,1
Nominal Frequency	Hz	60	50	60
Cooling Capacity	L35L35 W	975	1000	1050
Cooling Capacity	L35L50 W	700	720	800
Power Consumption	L35L50 W	580	595	730
Max current consumption.	A	5,45	3,5 (3,6 60°C)	4
Start-up current	CE A	---	20	20
Internal operating temp..	min/max °C	25/40	25/45	25/45
External operating temp.	min/max °C	20/50	20/60	20/55
Protection Degree internal circuit	CE IP	---	54	54
	UL Type	12	---	12
External sound pressure	dB(A)	56	56	56
Height (A)	mm	956	956	956
Width (B)	mm	375	375	375
Depth (C - C1 - C2)	mm	196 - 155 - 89	196 - 155 - 89	196 - 155 - 89
Weight	kg	34	34	34

CDE14

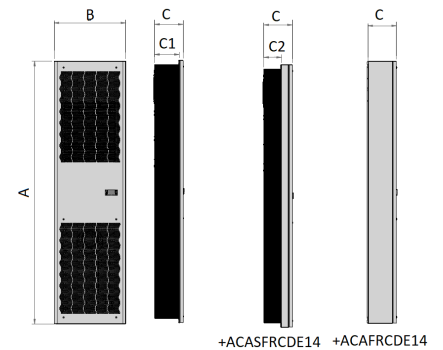

+ACASFR CDE14 +ACAFRCDE14

CODE	M.U.	CDE14U320380000	CDE14A322080000	CDE14U322080000	CDE14A322880000
UL LISTED		✓	--	✓	--
Rated Voltage	V, ~	115,1	230,1	230,1	400,2 460, 2
Nominal Frequency	Hz	60	50 60	50 60	50 60
Cooling Capacity	L35L35 W	1400	1400 1500	---	1500 1400 1500
Cooling Capacity	L35L50 W	1150	1150 1250	---	1250 1150 1250
Power Consumption	L35L50 W	855	730 820	---	820 730 820
Max current consumption.	A	9,2	5,4 6,1	3,9 (4,1 60°C)	4,23 2,7 2,4
Start-up current	CE A	---	28	28	43
Internal operating temp..	min/max °C	25/45	25/45	25/45	25/45
External operating temp.	min/max °C	20/55	20/60	20/60 20/55	20/60
Protection Degree internal circuit	CE IP	---	54	54	54
	UL Type	12	---	---	12 12 --
External sound pressure	dB(A)	60	60	60	60
Height (A)	mm	1666	1666	1666	1666
Wirdth (B)	mm	454	454	454	454
Depth (C - C1 - C2)	mm	181 - 156 - 111	181 - 156 - 111	181 - 156 - 111	181 - 156 - 111
Weight	kg	51	51	51	57

CDE20

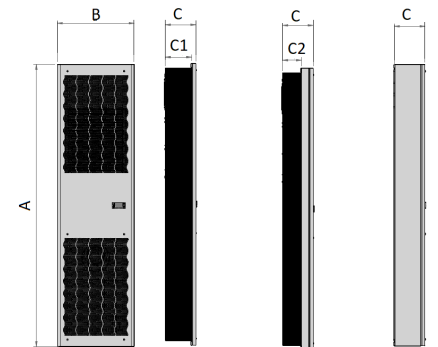

+ACASFR CDE14 +ACAFRCDE14

CODE	M.U.	CDE20U320380000	CDE20A322080000	CDE20U322080000	CDE20A326180000	CDE20U326280000
UL LISTED		✓	--	✓	--	✓
Rated Voltage	V, ~	115,1	230,1	230,1	400,3 460,3	400,3 460,3
Nominal Frequency	Hz	60	50 60	50 60	50 60	50 60
Cooling Capacity	L35L35 W	2100	2100 2200	---	2200 2100 2200	---
Cooling Capacity	L35L50 W	1700	1675 1700	---	1700 1675 1700	---
Power Consumption	L35L50 W	1220	1200 1430	---	1430 1020 1240	---
Max current consumption.	A	13,48	6,6 7,7	6,3 (6,6 60°C)	7,2 (2,2 60°C)	2,3 (2,2 60°C)
Start-up current	CE A	---	34	34	40	40
Internal operating temp..	min/max °C	25/45	25/45	25/45	25/45	25/45
External operating temp.	min/max °C	20/55	20/60	20/60 20/55	20/60 20/55	20/60 20/55
Protection Degree internal circuit	CE IP	---	54	54	54	54
	UL Type	12	---	---	12	---
External sound pressure	dB(A)	68	68	68	68	68
Height (A)	mm	1666	1666	1666	1666	1666
Wirdth (B)	mm	454	454	454	454	454
Depth (C - C1 - C2)	mm	181 - 156 - 111	181 - 156 - 111	181 - 156 - 111	181 - 156 - 111	181 - 156 - 111
Weight	kg	55	55	55	55	55

CDE30

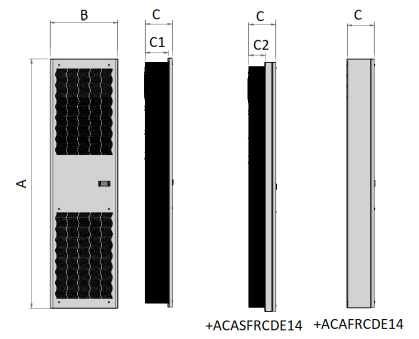

CODE	M.U.	CDE30A322080000	CDE30U322080000	CDE30A326180000	CDE30U326280000
UL LISTED		--	✓	--	✓
Rated Voltage	V, ~	230,1	230,1	400,3 460,3	400,3 460,3
Nominal Frequency	Hz	50 60	50 60	50 60	50 60
Cooling Capacity	L35L35 W	3050 3200	---	3200 3050	---
Cooling Capacity	L35L50 W	2500 2750	---	2750 2500	---
Power Consumption	L35L50 W	1295 1600	---	1600 1300	---
Max current consumption.	A	6,6 8	6,3 (6,6 60°C) 7,6	3,1 3,2	3 (3,1 60°C) 2,9
Start-up current	CE A	30	36	20	20
Internal operating temp..	min/max °C	25/45	25/45	25/45	25/45
External operating temp.	min/max °C	20/60	20/60 20/55	20/60	20/60 20/55
Protection Degree internal circuit	CE IP	54	54	54	54
	UL Type	---	---	12	---
External sound pressure	dB(A)	69	69	69	69
Height (A)	mm	1666	1666	1666	1666
Width (B)	mm	496	496	496	496
Depth (C - C1 - C2)	mm	221 -195 - 121	221 -195 - 121	221 -195 - 121	221 -195 - 121
Weight	kg	59	59	69	69

CDE40

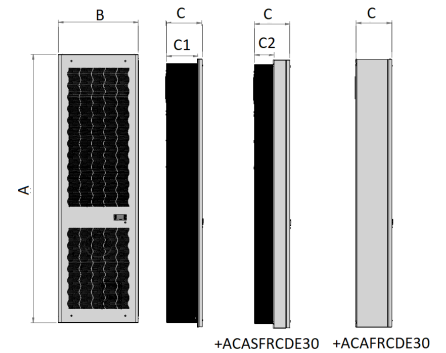

CODE	M.U.	CDE40A326180000	CDE40U326280000
UL LISTED		--	✓
Rated Voltage	V, ~	400,3 460,3	400,3 460,3
Nominal Frequency	Hz	50 60	50 60
Cooling Capacity	L35L35 W	3950 4095	-- 4095
Cooling Capacity	L35L50 W	3210 3400	-- 3400
Power Consumption	L35L50 W	1895 2390	-- 1815
Max current consumption.	A	4,2 4,7	3,3 3,5
Start-up current	CE A	25	21
Internal operating temp..	min/max °C	25/45	25/45
External operating temp.	min/max °C	20/60	20/55
Protection Degree internal circuit	CE IP	54	54
	UL Type	---	-- 12
External sound pressure	dB(A)	72	72
Height (A)	mm	1666	1666
Width (B)	mm	496	496
Depth (C - C1 - C2)	mm	256 -195 - 121	256 -195 - 121
Weight	kg	79	79

Optional Slim in CDE

CODE	Special Colour	Stainless Steel AISI304 Panel	Stainless Steel AISI316 Panel	Phase control module (3-phase models only)	Condenser protective treatment	Remote Probe
CDE05	OCASCCDE	OCAINCDE0405	OCAINCDE1605	--	OCATCCDE05	OCARESCDE
CDE10	OCASCCDE	OCAINCDE0405	OCAINCDE1605	--	OCATCCDE05	OCARESCDE
CDE14	OCASCCDE	OCAINCDE0414	OCAINCDE1614	--	--	OCARESCDE
CDE20	OCASCCDE	OCAINCDE0414	OCAINCDE1614	OCACFM	--	OCARESCDE
CDE30	OCASCCDE	OCAINCDE0430	OCAINCDE1630	OCACFM	--	OCARESCDE
CDE40	OCASCCDE	OCAINCDE0440	OCAINCDE1640	OCACFM	--	OCARESCDE

Accessories Slim in CDE

CODE	Semi-flush mounting frame	External mounting frame	Air filter - only for units in painted sheet metal	Sequencing Cable
CDE05	ACASFRCE05	ACAFRCDE05	ACAFLTCDE05	ACASEQ
CDE10	ACASFRCE05	ACAFRCDE05	ACAFLTCDE05	ACASEQ
CDE14	ACASFRCE14	ACAFRCDE14	ACAFLTCDE14	ACASEQ
CDE20	ACASFRCE14	ACAFRCDE14	ACAFLTCDE14	ACASEQ
CDE30	ACASFRCE30	ACAFRCDE30	ACAFLTCDE30	ACASEQ
CDE40	ACASFRCE30	ACAFRCDE30	ACAFLTCDE30	ACASEQ

Optional for Accessories Slim in CDE

CODE	Special Colour	Stainless Steel AISI 304	Stainless Steel AISI 316
ACASFRCE05	OCASCSFRCE	OCASFRICDE05	OCASFRCCDE05
ACAFRCDE05	OCASCFRCDE	OCAFRCDE05	OCAFRCDE14
ACASFRCE14	OCASCSFRCE	OCASFRICDE14	OCASFRCCDE14
ACAFRCDE14	OCASCFRCDE	OCAFRCDE14	OCAFRCDE14
ACASFRCE30	OCASCSFRCE	OCASFRICDE30	OCASFRCCDE30
ACAFRCDE30	OCASCFRCDE	OCAFRCDE30	OCAFRCDE30
ACAFLTCDE05	OCASCFLTCDE	--	--
ACAFLTCDE14	OCASCFLTCDE	--	--
ACAFLTCDE30	OCASCFLTCDE	--	--

FlexIn - Indoor

Industrial air conditioners with inverter technology

In the last few years all sectors have been transformed to achieve a better exchange of information in the shortest time possible. The need of connectivity between systems increased also in the industrial field, to improve the production processes. We have just entered the fourth industrial revolution, also known as **Industry 4.0**: all the systems should be designed to interact, with integrated connectivity to improve processes. Industrial air conditioning has adapted to this growing demand and the units have been improved with the introduction of the Modbus RTU serial connection and, in the last period, driven by the digitalisation of the production process, the Ethernet connection.



Connectivity 4.0

Thanks to the **Ethernet port, integrated** in the electronic controller of the FLEX In Inverter CDI the air conditioners can be **monitored** and **controlled** from any remote position 24 hours a day. Many parameters can be read and recorded, giving the possibility to **increase the efficiency** of the air conditioners and adopt the **predictive maintenance** and so the reliability, decreasing in this way possible faults of the air conditioner and of the whole system, without additional costs for interface device.

With its integrated Ethernet port, that allows the direct connection to the air conditioner with the most common industrial protocols (HTTP, SNMP, Modbus TCP/IP), the air conditioner CDI is perfectly integrated into Industry 4.0 and Smart Factory, leading to greater automation, real time production, **efficiency and flexibility**

Main Features

- Inverter Technology air conditioner
- High energy savings and High efficiency
- External, semi-flush or flush mounting
- Cooling Capacity: 2000W / 2600W / 4200W
- Quick electric connections
- Sequencing and Ethernet
- μ channel condenser with protective treatment
- Condensate Dissipator
- General alarm and remote enable contacts
- Gasket already installed on the air conditioner
- Functioning up to +60°C external temperature
- Low noise
- Certifications: CE, UL Listed, EAC



CDI20

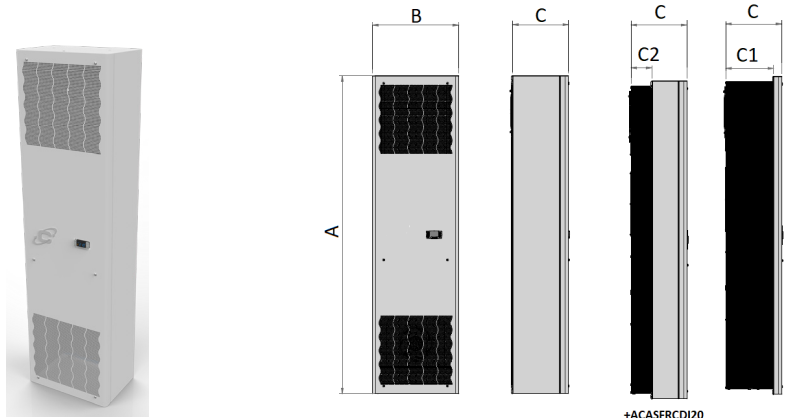

CODE	M.U.	CDI-20U(1-3)23G90000*	CDI-20U(1-3)23H90000*
UL Listed		✓	✓
Rated Voltage	V, ~	110...240,1	380...480,3
Nominal Frequency	Hz	50...60	50...60
Cooling Capacity	L35L35 W	2000	2000
Cooling Capacity	L35L50 W	1420	1420
Power Consumption	L35L50 W	610	575
Internal operating temp..	min/ max °C	+20...+45	+20...+45
External operating temp..	min/ max °C	-20...+60	-20...+60
Protection Degree internal circuit	CE IP	54	54
	UL Type	12	12
External sound pressure	dB(A)	61,5	61,5
Height (A)	mm	1666	1666
Width (B)	mm	454	454
Depth (C - C1 - C2)	mm	294 - 250 - 111	294 - 250 - 111

* 1: External mounting 3: Flush mounting

CDI26

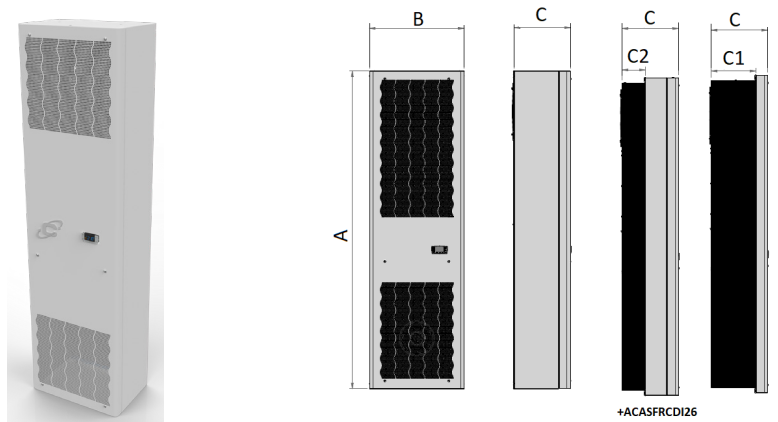

CODE	M.U.	CDI-26U(1-3)23G90000*	CDI-26U(1-3)23H90000*
UL Listed		✓	✓
Rated Voltage	V, ~	110...240,1	380...480,3
Nominal Frequency	Hz	50...60	50...60
Cooling Capacity	L35L35 W	2600	2600
Cooling Capacity	L35L50 W	2100	2100
Power Consumption	L35L50 W	1060	980
Internal operating temp..	min/ max °C	+20...+45	+20...+45
External operating temp..	min/ max °C	-20...+60	-20...+60
Protection Degree internal circuit	CE IP	54	54
	UL Type	12	12
External sound pressure	dB(A)	62,5	62,5
Height (A)	mm	1666	1666
Width (B)	mm	496	496
Depth (C - C1 - C2)	mm	294 - 232 - 121	294 - 232 - 121

* 1: External mounting 3: Flush mounting

CDI40

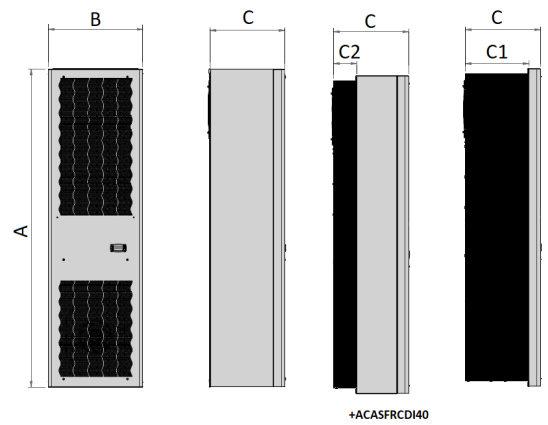
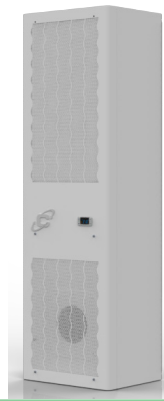

+ACASFRCDI40

CODE	M.U.	CDI-40U(1-3)23G90000*	CDI-40U(1-3)23H90000*
UL Listed		✓	✓
Rated Voltage	V, ~	110...240,1	380...480,3
Nominal Frequency	Hz	50...60	50...60
Cooling Capacity	L35L35 W	4200	4200
Cooling Capacity	L35L50 W	3350	3350
Power Consumption	L35L50 W	1385	1325
Internal operating temp..	min/ max °C	+20...+45	+20...+45
External operating temp.	min/ max °C	-20...+60	-20...+60
Protection Degree internal circuit	CE IP	54	54
	UL Type	12	12
External sound pressure	dB(A)	66	66
Height (A)	mm	1666	1666
Width (B)	mm	496	496
Depth (C - C1 - C2)	mm	393 - 332 - 121	393 - 332 - 121

* 1: External mounting 3: Flush mounting

Optional Flex In CDI

CODE	Special Colour	Stainless Steel AISI304 Panel	Stainless Steel AISI316 Panel
CDI20	OCASCCDI(U1-U3)	OCAINCDI04(U1-U3)	OCAINCDI16(U1-U3)
CDI26	OCASCCDI(U1-U3)	OCAINCDI04(U1-U3)	OCAINCDI16(U1-U3)
CDI40	OCASCCDI(U1-U3)	OCAINCDI04(U1-U3)	OCAINCDI16(U1-U3)

Accessories Flex In CDI

CODE	Semi-flush mounting frame	Air filter - only for units in painted sheet metal	Sequencing cable	LAN doubler for sequencing	Remote probe
CDI20	ACASFRCDI20	ACAFLTCDI20	ACASEQCDI	ACADLCDI	ACARESCDI
CDI26	ACASFRCDI26	ACAFLTCDI26	ACASEQCDI	ACADLCDI	ACARESCDI
CDI40	ACASFRCDI40	ACAFLTCDI26	ACASEQCDI	ACADLCDI	ACARESCDI

Optional Per Accessori Flex In CDI

CODE	Special Colour	Stainless steel AISI304	Stainless steel AISI316
ACASFRCDI20	OCASCSFRCDI	OCAFRCIDI	OCAFRCEDI
ACASFRCDI26	OCASCSFRCDI	OCAFRCIDI	OCAFRCEDI
ACASFRCDI40	OCASCSFRCDI	OCAFRCIDI	OCAFRCEDI
ACAFLTCDI20	OCASCSFRCDI	--	--
ACAFLTCDI26	OCASCSFRCDI	--	--
ACAFLTCDI40	OCASCSFRCDI	--	--

TOP II - Indoor

Industrial roof-mounted air conditioners allow the cooling of electrical cabinets even in situations where space is at a premium, such as in cabinet batteries or when escape routes must be left clear for safety reasons.

Effective Condensate Management

The solutions on the models allow optimal condensate management. The return air path ensures that no condensation forms on the roof of the cabinet and, in addition, from model ETE14 (1400W), the units are equipped with a condensate sink, without absorption of electrical power, for the reduction or elimination of condensation. For the models ETE06/09 there is a level switch to control the condensate in the condensate tray of the air conditioner.

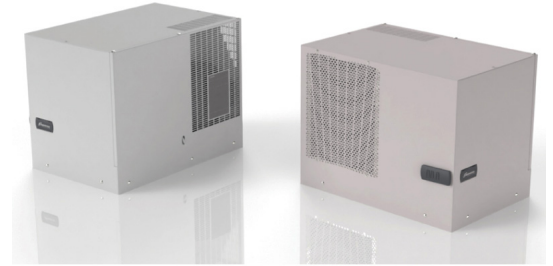

Optimized air flows

Thanks to the high distance between the intake and the supply of internal air, it is possible to avoid short circuits of cold air, without the need to install conveyors and guaranteeing reliable operation. In addition, starting from the ETE14 model, thanks to the management of the room air flow, it is possible to install air conditioners adjacent to each other, optimising installation layouts.

Main Features

- Cooling Capacity: 330-5200 W
- Condensate dissipator available from ETE14
- Quick connections (except ETE03)
- Digital Thermostat ECB (except ETE03)
- General alarm contacts and remote control as standard (except for ETE03)
- Certifications: CE, UL Recognized, EAC

ETE03

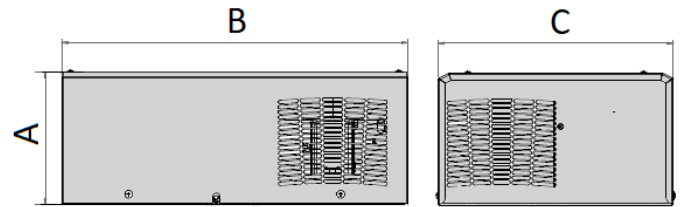

CODE	M.U.	ETE0300220	ETE0300203
UL Recognized		--	--
Rated Voltage	V, ~	230 , 1	115 , 1
Nominal Frequency	Hz	50/60	60
Cooling Capacity	L35L35 W	330	330
Cooling Capacity	L35L50 W	270	270
Power Consumption	L35L50 W	240	240
Current consumption	CE, L35L35 A	1,4	2,8
	UL, L45L55 A	--	--
Start-up current	A	5	10
Internal operating temp..	min/ max °C	+25 / +45	+25 / +45
External operating temp..	min/ max °C	+20 / +55	+20 / +55
Internal circuit protection degree	CE IP	54	54
	UL Type	--	--
External sound pressure	dB(A)	60	60
Height (A)	mm	180	180
Width (B)	mm	476	476
Depth (C)	mm	324	324
Weigth	kg	17	17

ETE06

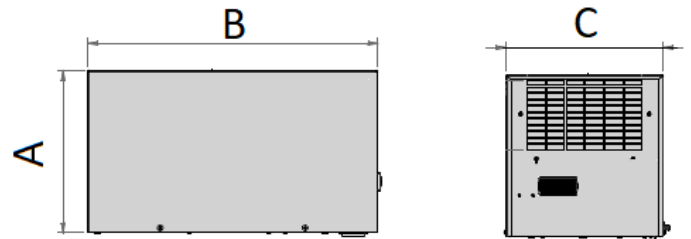

CODE	M.U.	ETE06012207000	ETE06U12207000	ETE06012287000
UL Recognized		--	✓	--
Rated Voltage	V, ~	230 , 1	230 , 1	400 , 2 460 , 2
Nominal Frequency	Hz	50/60	50-60	50 60
Cooling Capacity	L35L35 W	600	600	600
Cooling Capacity	L35L50 W	510	510	510
Power Consumption	L35L50 W	411	411	411
Current consumption	CE, L35L35 A	2,2		1,2
	UL, L45L55 A	--	3	--
Start-up current	A	16	16	7,7
Internal operating temp..	min/ max °C	+25 / +45	+25 / +45	+25 / +45
External operating temp..	min/ max °C	+20 / +55	+20 / +55	+20 / +55
Internal circuit protection degree	CE IP	54	54	54
	UL Type	--	--	--
External sound pressure	dB(A)	63	63	63
Height (A)	mm	335	335	335
Width (B)	mm	600	600	600
Depth (C)	mm	325	325	325
Weigth	kg	29,5	29,5	32

ETE09

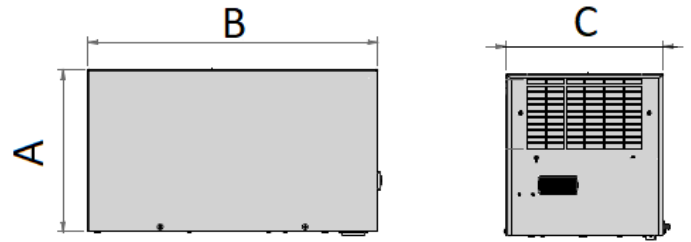

CODE	M.U.	ETE09012207000	ETE09U12207000	ETE09012287000
UL Recognized		--	✓	--
Rated Voltage	V, ~	230, 1	230, 1	400, 2 460, 2
Nominal Frequency	Hz	50/60	50/60	50 60
Cooling Capacity	L35L35 W	900	900	900
Cooling Capacity	L35L50 W	760	760	760
Power Consumption	L35L50 W	630	630	630
Current consumption	CE, L35L35 A	3,2	--	1,8
	UL, L45L55 A	--	4	--
Start-up current	A	15	15	31
Internal operating temp..	min/max °C	+25 / +45	+25 / +45	+25 / +45
External operating temp.	min/max °C	+20 / +55	+20 / +55	+20 / +55
Internal circuit protection degree	CE IP	54	54	54
	UL Type	--	--	--
External sound pressure	dB(A)	67	67	67
Height (A)	mm	335	335	335
Width (B)	mm	600	600	600
Depth (C)	mm	325	325	325
Weigth	kg	31,5	31,5	33

ETE14

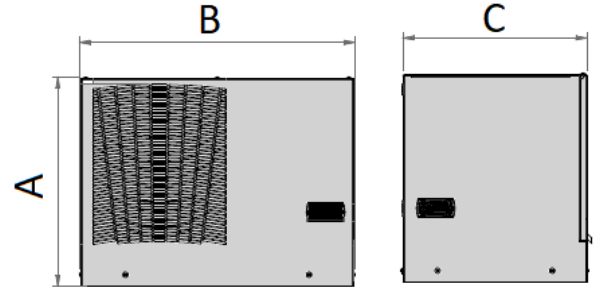

CODE	M.U.	ETE14002207000	ETE14U02207000	ETE14002287000
UL Recognized		--	✓	--
Rated Voltage	V, ~	230, 1	230, 1	400, 2 460, 2
Nominal Frequency	Hz	50/60	50/60	50 60
Cooling Capacity	L35L35 W	1400	1400	1400
Cooling Capacity	L35L50 W	1170	1170	1170
Power Consumption	L35L50 W	950	950	950
Current consumption	CE, L35L35 A	5,2	--	2,8
	UL, L45L55 A	--	5,5	--
Start-up current	A	17	17	31
Internal operating temp..	min/max °C	+25 / +45	+25 / +45	+25 / +45
External operating temp.	min/max °C	+20 / +55	+20 / +55	+20 / +55
Internal circuit protection degree	CE IP	54	54	54
	UL Type	--	--	--
External sound pressure	dB(A)	58	58	58
Height (A)	mm	450	450	450
Width (B)	mm	600	600	600
Depth (C)	mm	400	400	400
Weigth	kg	48	48	53

ETE20

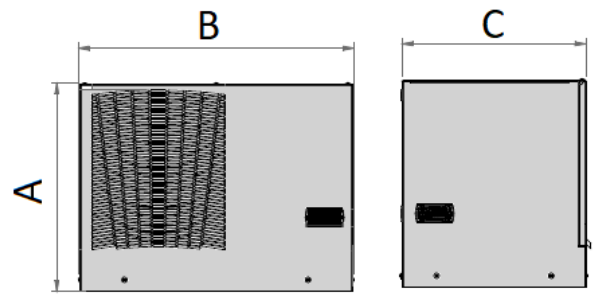

CODE	M.U.	ETE20002207000	ETE20U02207000	ETE20002287000
UL Recognized		--	✓	--
Rated Voltage	V, ~	230, 1	230, 1	400, 2 460, 2
Nominal Frequency	Hz	50/60	50/60	50 60
Cooling Capacity	L35L35 W	2000	2000	2000
Cooling Capacity	L35L50 W	1700	1700	1700
Power Consumption	L35L50 W	1200	1200	1200
Current consumption	CE, L35L35 A	5,7	--	3,3
	UL, L45L55 A	--	7	--
Start-up current	A	22	22	31
Internal operating temp..	min/max °C	+25 / +45	+25 / +45	+25 / +45
External operating temp.	min/max °C	+20 / +55	+20 / +55	+20 / +55
Internal circuit protection degree	CE IP	54	54	54
	UL Type	--	--	--
External sound pressure	dB(A)	62	62	62
Height (A)	mm	450	450	450
Width (B)	mm	600	600	600
Depth (C)	mm	400	400	400
Weigth	kg	51,5	51,5	58,5

ETE28

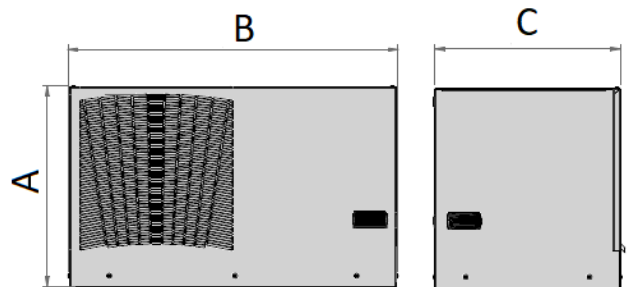

CODE	M.U.	ETE28002207000	ETE28U02207000	ETE28002617000
UL Recognized		--	✓	--
Rated Voltage	V, ~	230, 1	230, 1	400, 3 460, 3
Nominal Frequency	Hz	50/60	50/60	50 60
Cooling Capacity	L35L35 W	2700	2700	2700
Cooling Capacity	L35L50 W	2300	2300	2300
Power Consumption	L35L50 W	1580	1660	1580
Current consumption	CE, L35L35 A	7	--	2,3
	UL, L45L55 A	--	9,5	--
Start-up current	A	38	38	16
Internal operating temp..	min/max °C	+25 / +45	+25 / +45	+25 / +45
External operating temp.	min/max °C	+20 / +55	+20 / +55	+20 / +55
Internal circuit protection degree	CE IP	54	54	54
	UL Type	--	--	--
External sound pressure	dB(A)	77	77	77
Height (A)	mm	480	480	480
Width (B)	mm	800	800	800
Depth (C)	mm	450	450	450
Weigth	kg	74,5	74,5	76,5

ETE41

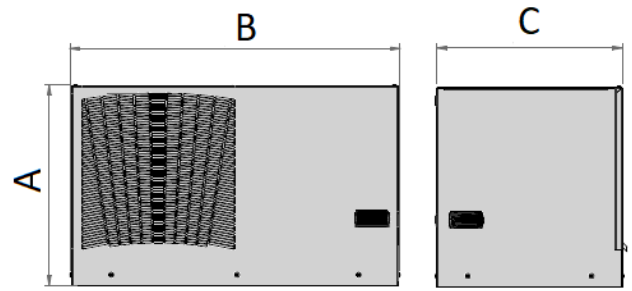

CODE	M.U.	ETE41002207000	ETE41U02207000	ETE41002617000	ETE41U02627200
UL Recognized		--	✓	--	✓
Rated Voltage	V, ~	230, 1	230, 1	400, 3 460, 3	400, 3 460, 3
Nominal Frequency	Hz	50/60	50/60	50 60	50 60
Cooling Capacity	L35L35 W	3800	3800	3800	3800
Cooling Capacity	L35L50 W	2700	2700	2700	2700
Power Consumption	L35L50 W	2000	2050	2000	1920
Current consumption	CE, L35L35 A	9	--	2,9	--
	UL, L45L55 A	--	9	--	3,5
Start-up current	A	38	--	17	--
Internal operating temp..	min/max °C	+25 / +45	+25 / +45	+25 / +45	+25 / +45
External operating temp.	min/max °C	+20 / +55	+20 / +55	+20 / +55	+20 / +55
Internal circuit protection degree	CE IP	54	54	54	54
	UL Type	--	--	--	--
External sound pressure	dB(A)	77	77	77	77
Height (A)	mm	480	480	480	480
Width (B)	mm	800	800	800	800
Depth (C)	mm	450	450	450	450
Weigth	kg	76.5	76.5	79.5	76.5

ETE60

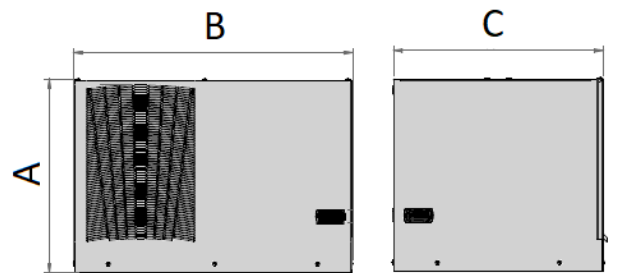

CODE	M.U.	ETE60002617000
UL Recognized		--
Rated Voltage	V, ~	400, 3 460, 3
Nominal Frequency	Hz	50 60
Cooling Capacity	L35L35 W	5200
Cooling Capacity	L35L50 W	4100
Power Consumption	L35L50 W	2540
Current consumption	CE, L35L35 A	4,6
	UL, L45L55 A	--
Start-up current	A	25
Internal operating temp..	min/max °C	+25 / +45
External operating temp.	min/max °C	+20 / +55
Internal circuit protection degree	CE IP	54
	UL Type	--
External sound pressure	dB(A)	77
Height (A)	mm	550
Width (B)	mm	800
Depth (C)	mm	600
Weigth	kg	94

Optional Top II ETE

CODE	Special Colour	Stainless Steel AISI304 housing
ETE03	OCAHNS02	OCAHI06
ETE06	OCAHNS03	OCAHI06
ETE09	OCAHNS03	OCAHI06
ETE14	OCAHNS03	OCAHI06
ETE20	OCAHNS03	OCAHI06
ETE28	OCAHNS01	OCAHI28
ETE41	OCAHNS01	OCAHI28
ETE60	OCAHNS01	OCAHI60

Accessories Top II ETE

CODE	Filter
ETE03	--
ETE06	ACAFILT06T
ETE09	ACAFILT06T
ETE14	ACAFILT14T
ETE20	ACAFILT14T
ETE28	ACAFILT28T
ETE41	ACAFILT28T
ETE60	ACAFILT60T

Module - Indoor

Industrial air conditioners for modular electrical enclosures

Module air conditioners are the best technical and economical solution for conditioning long rows of cabinets, where large cooling capacities are required.

Machine tools, such as for die-casting or extrusion, may require large automation and control systems with high thermal loads, even above 4kW. In this case, the Module range with 6kW to 10kW enables the required cooling needs to be met optimally.



Main Features

- Air conditioner for modular enclosures
- Cooling Capacity: 5800-10000 W
- Digital Thermostat ECB
- General alarm contacts and remote control as standard
- Certifications: CE, EAC

EVE60-80-Ao

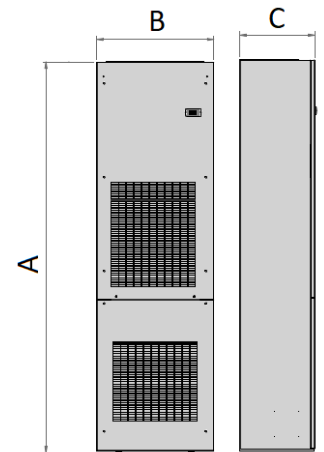
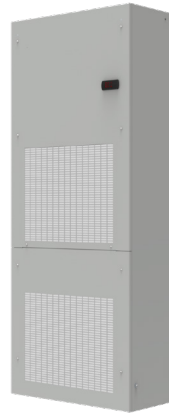

CODE	M.U.	EVE60002617000	EVE80002617000	EVEA0002617000
Rated Voltage	V, ~	400,3 460,3	400,3 460,3	400,3 460,3
Nominal Frequency	Hz	50 60	50 60	50 60
Cooling Capacity	L35L35 W	5800	8000	10000
Cooling Capacity	L35L50 W	4500	5900	7800
Power Consumption	L35L50 W	2614	3619	4500
Current consumption	CE, 35L35 A	5,8	7	7
Start-up current	CE A	28	28	40
Internal operating temp..	min/max °C	+25 / +45	+25 / +45	+25 / +45
External operating temp.	min/max °C	+20 / +50	+20 / +50	+20 / +50
Internal circuit protection degree	CE IP	54	54	54
External sound pressure	dB(A)	75	76	76
Height (A)	mm	2000	2000	2000 x 800 x 383
Width (B)	mm	600	800	800
Depth (C)	mm	383	383	383
Weigth	kg	100	110	150

Optional Module EVE

CODE	Special Colour	Stainless Steel AISI304 housing
EVE60	OCAVNS01	OCAVIMO
EVE80	OCAVNS01	OCAVIMO
EVEAo	OCAVNS01	OCAVIMO

Smart - Indoor

The solution for horizontal boxes

Some applications, such as small boxes integrated in machine tools, run horizontally rather than vertically. The Smart industrial air conditioner is the ideal solution because its horizontal layout, with compact height and depth dimensions, allows for simple and immediate installation on the machine or on control panels.



Main Features Generali

- Horizontal Installation
- Cooling Capacity: 420W
- Power Supply 230 50/60 Hz
- Mechanic Thermostat
- Certifications: CE, EAC

EVE03H

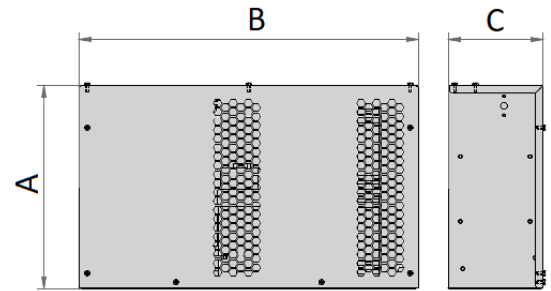

CODE	M.U.	EVE03H3220
Rated Voltage	V, ~	230, 1
Nominal Frequency	Hz	50/60
Cooling Capacity	L35L35 W	420
Cooling Capacity	L35L50 W	280
Power Consumption	L35L50 W	300
Current consumption	CE, L35L35 A	1,2
Start-up current	CE A	3
Internal operating temp..	min/max °C	+25 / +45
External operating temp.	min/max °C	+20 / +55
Internal circuit protection degree	CE IP	54
External sound pressure	dB(A)	60
Height (A)	mm	300
Width (B)	mm	500
Depth (C)	mm	140
Weight	kg	17

Optional Smart EVE03H

CODE	Special Colour	Stainless Steel AISI304 housing
EVE03H	OCAVNS02	OCAVISM

Rack - Indoor

The solution for 19" server racks

Small servers require low heat loads and small dimensions. The ERE air conditioner, with a footprint of only 7 rack units and an output of approximately 1000W, is suitable for cooling 19 cabinets. In addition to the compact dimensions, the panel mounting and the choice of internal air flows ensure easy and flexible installation in the server rack.

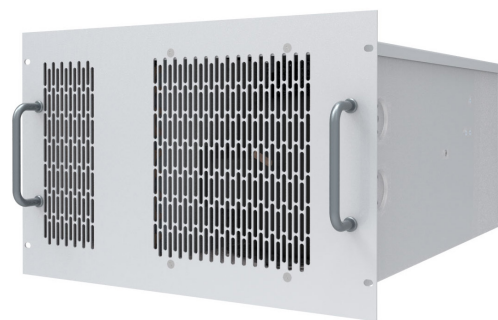

Main Features

- For Rack 19" cooling
- Cooling Capacity: 950 W
- 7 rack units
- Certifications: CE, EAC

ERE10

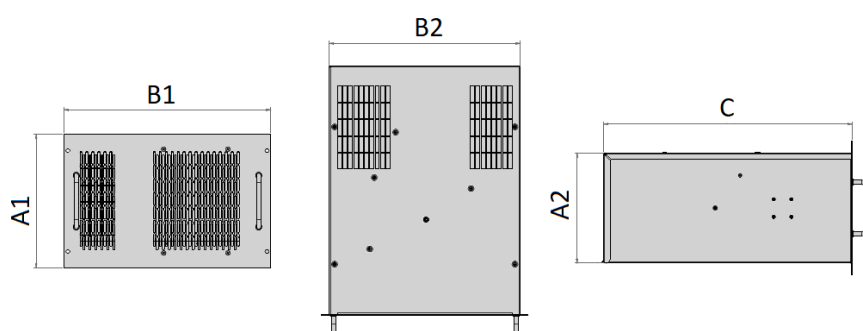

CODE	M.U.	ERE1000320
Rated Voltage	V, ~	230, 1
Nominal Frequency	Hz	50/60
Cooling Capacity	L35L35 W	950
Cooling Capacity	L35L50 W	760
Power Consumption	L35L50 W	630
Current consumption	CE, L35L35 A	3
Start-up current	CE A	15
Internal operating temp..	min/max °C	+25 / +45
External operating temp.	min/max °C	+20 / +55
Internal circuit protection degree	CE IP	54
External sound pressure	dB(A)	65
Height (A)	mm	311
Width (B)	mm	482.6 - 446
Depth (C)	mm	580.5
Weigth	kg	36

Predator - Outdoor

High efficiency for outdoor installations

The Predator line offers a range of high-efficiency precision air conditioners for outdoor installations such as shelters/cabinets for telecommunications, power distribution, fibre optics, etc.

48 VDC version

The 48Vdc version is particularly suitable for cabinets powered by renewable energy sources, such as solar, wind or battery backup.



Free Cooling

Predator units can be equipped with Free Cooling. Thanks to the direct use of external air, whenever the external air temperature is lower than the internal one, the cabinet is cooled "without cost".

Direct Free Cooling is the best solution for energy saving and ensures a considerable cost reduction.

How does Free Cooling work?

An alternative system to direct expansion cooling, which uses suitably filtered ambient air to cool the cabinet. The system automatically expels hot air from the cabinet, in the same quantity as that injected. A motorized damper mixes the external air flow and discharge air flow, by modulating the free cooling capacity.

Predator air conditioners, thanks to their high air flow rate in Direct Free Cooling, represent the best solution for energy saving. Whenever environmental conditions allow it, Predator works in free cooling mode; in this mode the evaporator fan is the only component in operation, while compressor and condenser fan are switched off.

Direct free cooling combined with emergency ventilation guarantees service continuity, even in the event of a main power failure, if the operating conditions can guarantee the functioning.

Main Features

- Internal, external or semi-flush mounting
- Cooling Capacity 1000/2000W
- Functioning up to +60°C (ambient temperature)
- Certifications: CE, EAC
- Available configurations:
 - with Free Cooling without emergency ventilation
 - with Free Cooling and 48VDC emergency ventilation

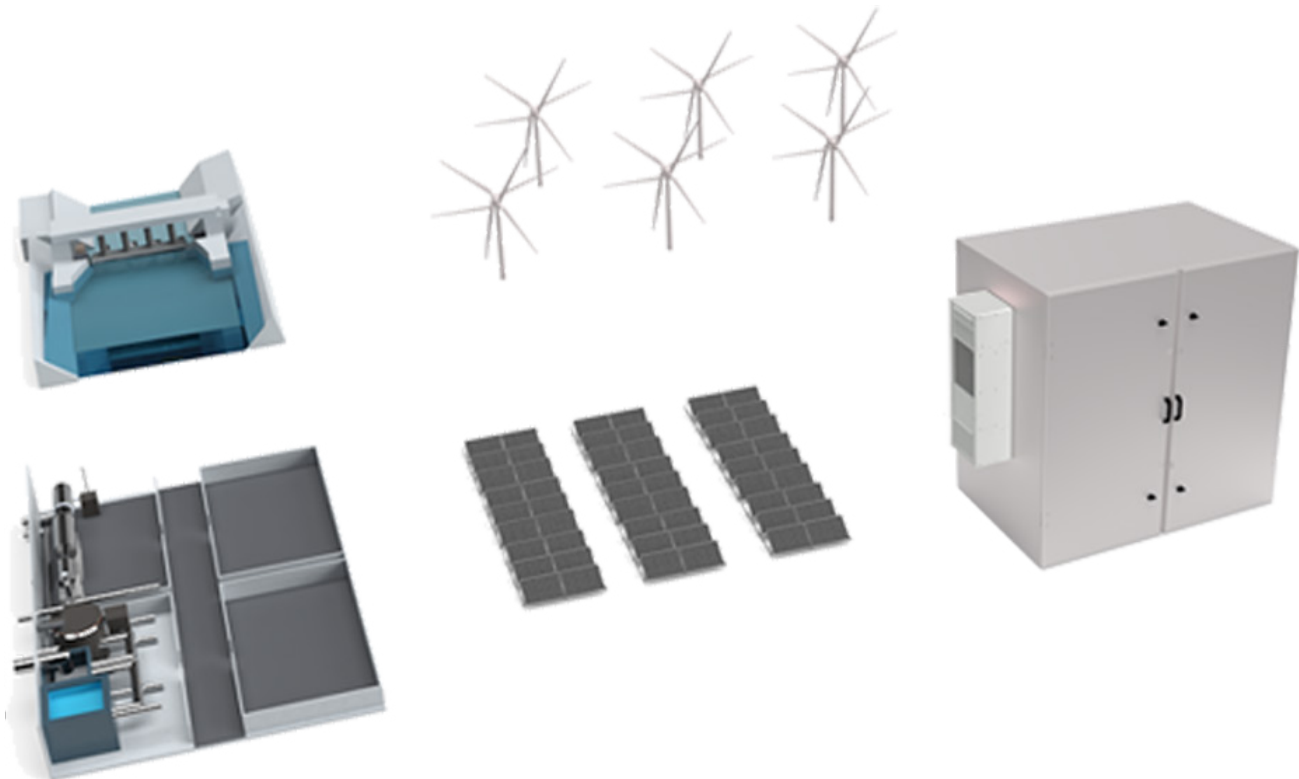

PRT10H/F PRT100

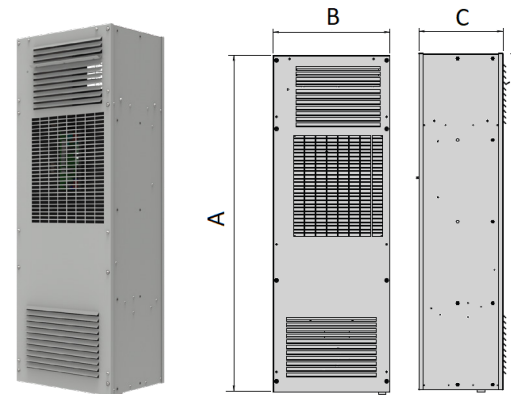

CODE	M.U.	PRT10HA3201000	PRT10FA3201000
Power Supply	V - Hz	230-1-50/60 + 48VDC	230 - 1 - 50/60
Cooling Capacity	L35L35 W	1000	1000
Cooling Capacity	L35L50 W	750	750
Power consumption - L35L50	@230VAC W	600	600
	@48VDC W	110	--
Current consumption - L35L35	@230VAC A	2,5	2,7
	@48VDC A	2,6	--
Start-up current	@230VAC A	16	16
Internal operating temp..	min/ max °C	+25 / +45	+25 / +45
External operating temp.	min/ max °C	-20 / +60	-20 / +60
Internal circuit protection degree	CE IP	54	54
External sound pressure	dB(A)	59	59
Height (A)	mm	1200	1200
Width (B)	mm	417	417
Depth (C)	mm	300	300
Weigth	kg	59	59

PRT14H/F

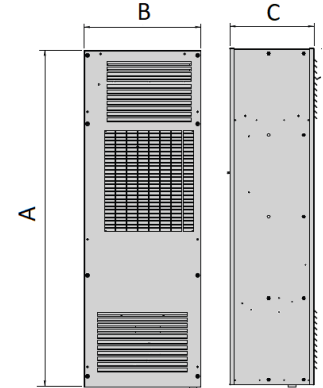

CODE	M.U.	PRT14HA3201000	PRT14FA3201000
Power Supply	V - Hz	230-1-50/60 +48VDC	230-1-50/60
Cooling Capacity	L35L35 W	1400	1400
Cooling Capacity	L35L50 W	1000	1000
Power consumption - L35L50	@230VAC W	770	770
	@48VDC W	100	--
Current consumption - L35L35	@230VAC A	4,3	4,5
	@48VDC A	2,4	--
Start-up current	@230VAC A	17	17
Internal operating temp..	min/ max °C	+25 / +45	+25 / +45
External operating temp.	min/ max °C	-20 / +60	-20 / +60
Internal circuit protection degree	CE IP	54	54
External sound pressure	dB(A)	59	59
Height (A)	mm	1200	1200
Width (B)	mm	417	417
Depth (C)	mm	300	300
Weigth	kg	61	61

PRT20H/F PRT200

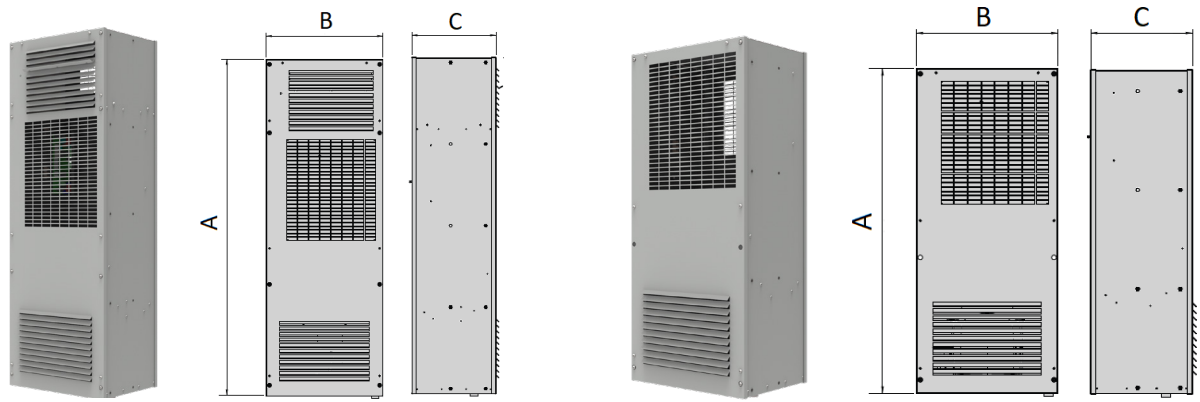

CODE	M.U.	PRT20HA3201000	PRT20FA3201000	PRT20FD3121000	PRT200D3121000
Power Supply	V - Hz	230-1-50/60 +48VDC	230-1-50/60	48VDC	48VDC
Cooling Capacity	L35L35 W	2000	2000	2000	2000
Cooling Capacity	L35L50 W	1750	1750	1750	1750
Power consumption - L35L50	@230VAC W	1100	1200	--	--
	@48VDC W	100	--	1390	1390
Current consumption - L35L35	@230VAC A	5.5	5.3	--	--
	@48VDC A	2.4	--	29	29
Start-up current	@230VAC A	20	20	--	--
Internal operating temp..	min/ max °C	+25 / +45	+25 / +45	+25 / +45	+25 / +45
External operating temp.	min/ max °C	-20 / +60	-20 / +60	-20 / +60	-20 / +60
Internal circuit protection degree	CE IP	54	54	54	54
External sound pressure	dB(A)	60	60	69	69
Height (A)	mm	1200	1200	1200	955
Width (B)	mm	417	417	417	417
Depth (C)	mm	300	300	300	300
Weigth	kg	63	63	61	58

Optional Predator PRT

CODE	Free Cooling	Emergency Ventilation	Electrical Heating
PRT10FA3201000	•	--	--
PRT10HA3201000	•	•	RSC0.6 / RSC1.0
PRT14FA3201000	•	--	--
PRT14HA3201000	•	•	RSC0.6 / RSC1.0
PRT20FA3201000	•	--	--
PRT20HA3201000	•	•	RSC0.6 / RSC1.0
PRT200D3121000	--	--	--
PRT20FD3121000	•	--	--

Accessories Predator PRT

CODE	Keypad	Flush and Semi-flush mounting frame
PRT10FA3201000	ACTKPDC1010HNL	ACTBSFPRT01FC
PRT10HA3201000	ACTKPDC1010HNL	ACTBSFPRT01FC
PRT14FA3201000	ACTKPDC1010HNL	ACTBSFPRT01FC
PRT14HA3201000	ACTKPDC1010HNL	ACTBSFPRT01FC
PRT20FA3201000	ACTKPDC1010HNL	ACTBSFPRT01FC
PRT20HA3201000	ACTKPDC1010HNL	ACTBSFPRT01FC
PRT200D3121000	ACTKPDC1010HNL	ACTBSFPRT01
PRT20FD3121000	ACTKPDC1010HNL	ACTBSFPRT01FC

EXW - Indoor

A cooling capacity for every requirement

The EXW range of water/air heat exchangers has a wide range of cooling capacities to meet all requirements. The range offers compact sized units for cooling electrical panels up to 6700W and larger units for cooling panels with high thermal loads, up to 25000W. Two models for rooftop installation (2200W and 6700W) complete the offer.

Control

EXW wall-mounted water/air heat exchangers can be equipped with a mechanical thermostat and solenoid valve to control the water flow required by the exchanger. The roof-top heat exchangers have as standard an electronic thermostat which, in addition to controlling the solenoid valve and the water flow, provides a general alarm, remote control and condensate level control to ensure safety and reliability.



Main Features

- Cooling capacity: 870-25000 W
- Wall or roof (EXW15H0 ed EXW50H0) mounting
- Certifications: CE, UL Listed

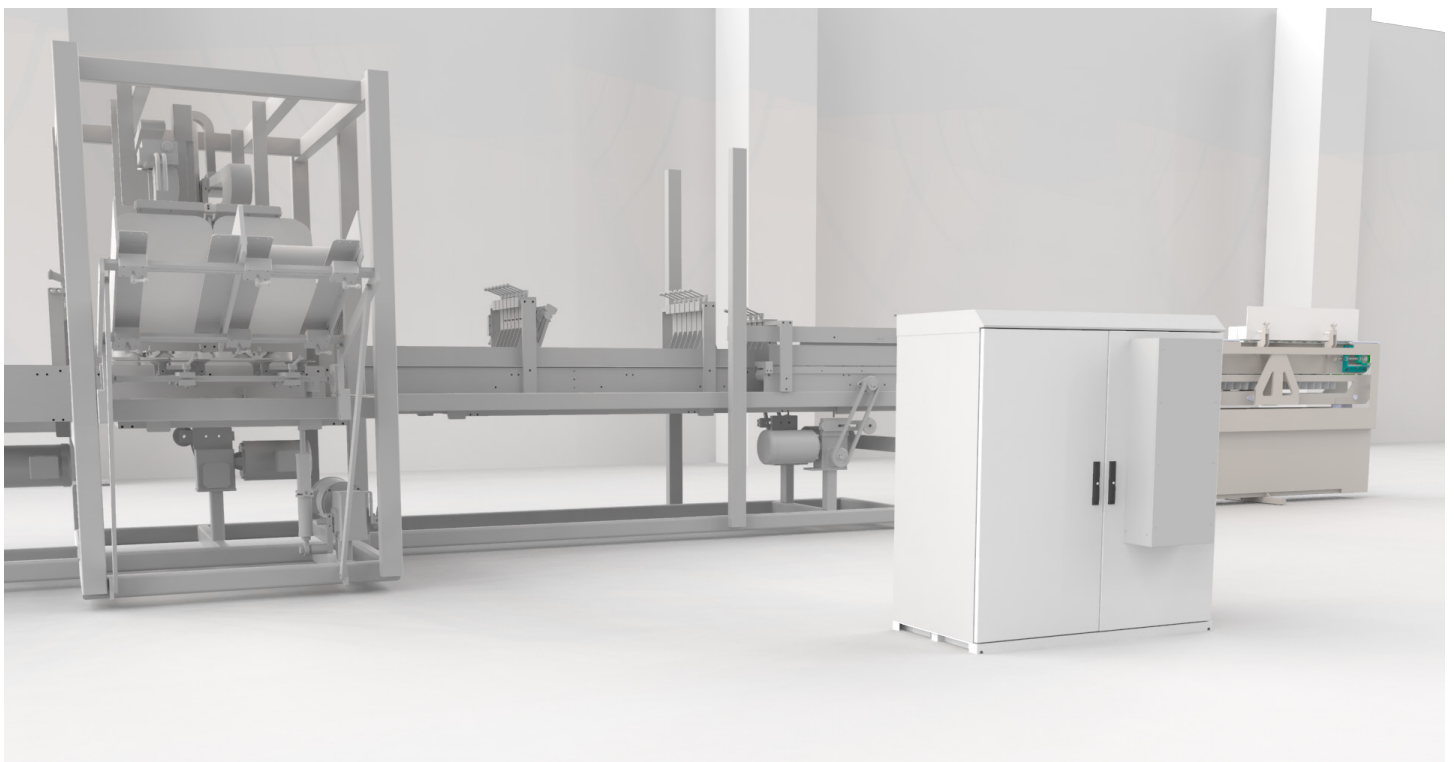

EXWo6

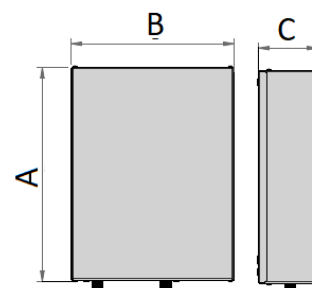

CODE	M.U.	EXWo600220	EXWo6U1220	EXWo6U1222
UL Listed		--	✓	✓
Rated Voltage	V, ~	230, 1	230, 1	115, 1
Nominal Frequency	Hz	50 60	50/60	60
Cooling Capacity	$\Delta T=25^{\circ}\text{C}$ W	870	870	870
Current Consumption	A	0,28 0,24	0,5	0,5
Absorbed fan power	W	33 36	25	24
Water Flow	l/h	150	150	150
Max water pressure	kPa	500	500	500
Water pressure drop	kPa	2	2	2
Internal operating Temp.	min/ max °C	+10 / +55	+10 / +55	+10 / +55
Water connection diam.	"	3 / 8	3 / 8 NPT	3 / 8 NPT
Internal circuit protection degree	CE IP	55	--	--
	UL Type	--	12	12
External sound pressure	dB(A)	35	35	35
Height (A)	mm	403	403	403
Width (B)	mm	306	306	306
Depth (C)	mm	113	113	113
Weigth	kg	7	7	7

EXW15

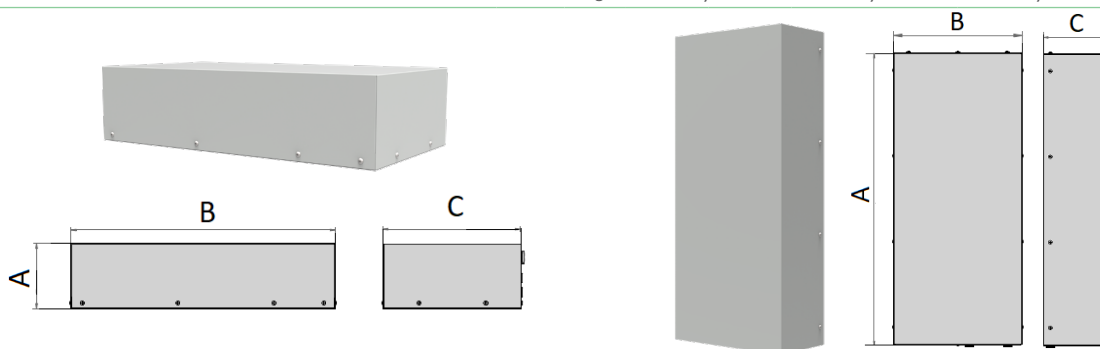

CODE	M.U.	EXW1500220	EXW15U1220	EXW15U1222	EXW15Ho2207000
UL Listed		--	✓	✓	--
Rated Voltage	V, ~	230, 1	230, 1	115, 1	230, 1
Nominal Frequency	Hz	50 60	50/60	60	50 60
Cooling Capacity	$\Delta T=25^{\circ}\text{C}$ W	2200	2200	2200	2200
Current Consumption	A	0,23 0,29	0,8	0,8	0,23 0,29
Absorbed fan power	W	52 65	75	90	52 65
Water Flow	l/h	150	150	150	150
Max water pressure	kPa	1000	1000	1000	1000
Water pressure drop	kPa	30	30	30	30
Internal operating Temp.	min/ max °C	+10 / +55	+10 / +55	+10 / +55	+10 / +65
Water connection diam.	"	1 / 2	1 / 2 NPT	1 / 2 NPT	1 / 2
Internal circuit protection degree	CE IP	55	--	--	54
	UL Type	--	12	12	--
External sound pressure	dB(A)	45	45	45	45
Height (A)	mm	916	916	916	189 x 772 x 404
Width (B)	mm	402	402	402	
Depth (C)	mm	206	206	206	
Weigth	kg	20	21	21	30

EXW25

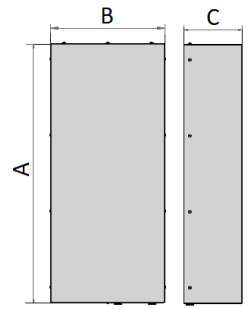

CODE	M.U.	EXW2500220	EXW25U1220	EXW25U1222
UL Listed		--	✓	✓
Rated Voltage	V, ~	230, 1	230, 1	115, 1
Nominal Frequency	Hz	50 60	50/60	60
Cooling Capacity	$\Delta T=25^{\circ}\text{C}$ W	3100	3100	3100
Current Consumption	A	0,36 0,46	1	1
Absorbed fan power	W	80 100	90	115
Water Flow	l/h	500	500	500
Max water pressure	kPa	1000	1000	1000
Water pressure drop	kPa	63	63	63
Internal operating Temp.	min/ max °C	+10 / +55	+10 / +55	+10 / +55
Water connection diam.	"	1 / 2	1 / 2 NPT	1 / 2 NPT
Internal circuit protection degree	CE IP	55	--	--
	UL Type	--	12	12
External sound pressure	dB(A)	45	45	45
Height (A)	mm	916	916	916
Width (B)	mm	402	402	402
Depth (C)	mm	206	206	206
Weighth	kg	21	22	22

EXW50

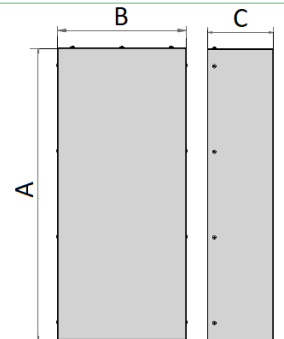
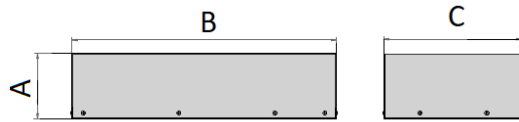

CODE	M.U.	EXW5000220	EXW50U1220	EXW50U1222	EXW50H02207000
UL Listed		--	✓	✓	--
Rated Voltage	V, ~	230, 1	230, 1	115, 1	230, 1
Nominal Frequency	Hz	50 60	50/60	60	50 60
Cooling Capacity	$\Delta T=25^{\circ}\text{C}$ W	6700	6700	6700	6700
Current Consumption	A	1,02 1,5	1,3	2	1,02 1,5
Absorbed fan power	W	230 340	285	155	260 340
Water Flow	l/h	860	860	860	860
Max water pressure	kPa	1000	1000	1000	1000
Water pressure drop	kPa	40	40	40	30
Internal operating Temp.	min/ max °C	+10 / +55	+10 / +55	+10 / +55	+10 / +55
Water connection diam.	"	1 / 2	1 / 2 NPT	1 / 2 NPT	1 / 2
Internal circuit protection degree	CE IP	55	--	--	54
	UL Type	--	12	12	--
External sound pressure	dB(A)	45	45	45	45
Height (A)	mm	1091	1091	1091	255
Width (B)	mm	503	503	503	905
Depth (C)	mm	293	293	293	509
Weighth	kg	39	39	39	39

EXWA0

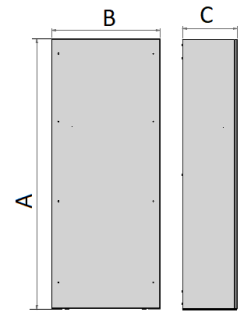

CODE	M.U.	EXWA000220		EXWA000230	
UL Listed		--		--	
Rated Voltage	V, ~	230, 1		400, 2	460, 2
Nominal Frequency	Hz	50	60	50	60
Cooling Capacity	$\Delta T=25^{\circ}\text{C}$ W	12500		12500	
Current Consumption	A	2	3	1	1,18
Absorbed fan power	W	460	680	460	680
Water Flow	L/h	1440		1440	
Max water pressure	kPa	1000		1000	
Water pressure drop	kPa	90		90	
Internal operating Temp.	min/ max °C	+10 / +55		+10 / +55	
Water connection diam.	"	3 / 4		3 / 4	
Internal circuit protection degree	CE IP	54		54	
	UL Type	--		--	
External sound pressure	dB(A)	50		50	
Height (A)	mm	2000		2000	
Width (B)	mm	800		800	
Depth (C)	mm	400		400	
Weigth	kg	90		90	

EXWA5

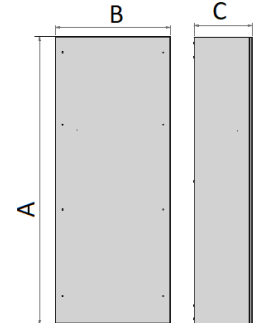

CODE	M.U.	EXWA500220		EXWA500230	
UL Listed		--		--	
Rated Voltage	V, ~	230, 1		400, 2	460, 2
Nominal Frequency	Hz	50	60	50	60
Cooling Capacity	$\Delta T=25^{\circ}\text{C}$ W	17500		17500	
Current Consumption	A	0,78	1,1	0,42	0,56
Absorbed fan power	W	170	250	170	250
Water Flow	L/h	2520		2520	
Max water pressure	kPa	1000		1000	
Water pressure drop	kPa	121		121	
Internal operating Temp.	min/ max °C	+10 / +55		+10 / +55	
Water connection diam.	"	3 / 4		3 / 4	
Internal circuit protection degree	CE IP	54		54	
	UL Type	--		--	
External sound pressure	dB(A)	50		50	
Height (A)	mm	2000		2000	
Width (B)	mm	800		800	
Depth (C)	mm	600		600	
Weigth	kg	90		90	

EXWBo

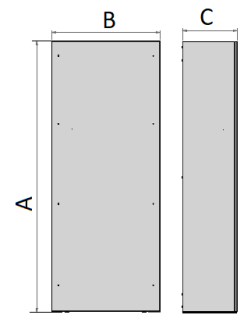

CODE	M.U.	EXWB000220		EXWB000230	
UL Listed		--		--	
Rated Voltage	V, ~	230, 1		400, 2	460, 2
Nominal Frequency	Hz	50	60	50	60
Cooling Capacity	$\Delta T=25^{\circ}\text{C}$ W	25000		25000	
Current Consumption	A	2,2	2,8	0,85	1,13
Absorbed fan power	W	340	500	340	500
Water Flow	l/h	1800		1800	
Max water pressure	kPa	1000		1000	
Water pressure drop	kPa	65		65	
Internal operating Temp.	min/ max °C	+10 / +50		+10 / +50	
Water connection diam.	"	3 / 4		3 / 4	
Internal circuit protection degree	CE IP	54		54	
	UL Type	--		--	
External sound pressure	dB(A)	50		50	
Height (A)	mm	2000		2000	
Width (B)	mm	800		800	
Depth (C)	mm	600		600	
Weighth	kg	95		95	

Optional EXW

CODE	Special Colour	Solenoid Valve + Thermostat	Stainles Steel AISI304 housing
EXW06	OCAXNS06	OCAEVT1	OCAXI04
EXW15	OCAXNS08	OCAEVT2	OCAXI05
EXW15H	OCAXNS08	STD	OCAXI05
EXW25	OCAXNS08	OCAEVT2	OCAXI05
EXW50	OCAXNS10	OCAEVT2	OCAXI06
EXW50H	OCAXNS10	STD	OCAXI06
EXWA0	OCAXNS10	OCAEVT4	--
EXWA5	OCAXNS11	OCAEVT4	--
EXWBo	OCAXNS11	STD	--

XVA - Indoor

Flexible Installation

Thanks to their compact dimensions, XVA air/air heat exchangers can be installed in all electrical cabinets, even in applications where limited space is required in terms of width and depth. The industrial heat exchangers can be installed externally, but also internally, so as to eliminate any external clutter in the electrical cabinet.

Efficiency and Noise Reduction

XVA heat exchangers can be integrated with a mechanical thermostat to control the external fan. When the set point is reached, the fan is switched off, thus obtaining advantages in terms of efficiency (lower power consumption) and noise (no operation).



Main Features

- Installation: internal/external
- Patented heat exchange core made of aluminium, to ensure high efficiency with compact dimensions
- Specific heat transmission 16-85 W/k
- Certifications: CE, UL Listed

XVA16

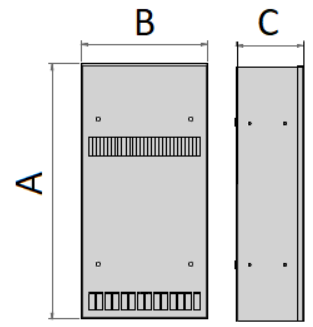

CODE	M.U.	XVA1600320	XVA16U1303
UL Listed		--	✓
Rated Voltage	V, ~	230, 1	115, 1
Nominal Frequency	Hz	50/60	60
Specific heat transmission	W/K	16	16
Current Consumption	A	0,6	0,6
Absorbed fan power	W	64	40
Internal operating Temp	min/max °C	-5 / +55	-5 / +55
Ambient temperature limit	min/max °C	-5 / +55	-5 / +55
Internal circuit protection degree	CE IP	54	--
	UL Type	--	12
External sound pressure	dB(A)	58	58
Height (A)	mm	410	410
Width (B)	mm	204	204
Depth (C)	mm	109	109
Installation		Internal / External	External
Machanic Thermostat		No	No
Weigth	kg	4,6	4,6

XVA35

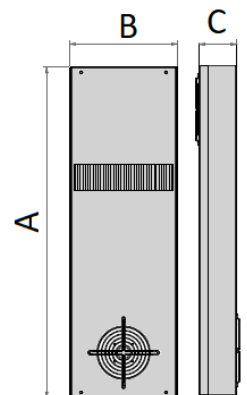
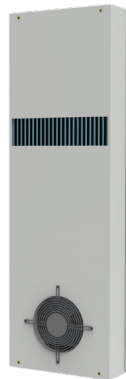

CODE	M.U.	XVA3500320	XVA35T0120	XVA35T0220	XVA35U1320	XVA35U1303
UL Listed		--	--	--	✓	✓
Rated Voltage	V, ~	230, 1	230, 1	230, 1	230, 1	115, 1
Nominal Frequency	Hz	50 60	50 60	50 60	50/60	60
Specific heat transmission	W/K	35	35	35	35	35
Current Consumption	A	0,46 0,58	0,46 0,58	0,46 0,58	0,8	1,1
Absorbed fan power	W	100 130	100 130	100 130	150	180
Internal operating Temp	min/max °C	-5 / +55	-5 / +55	-5 / +55	-5 / +55	-5 / +55
Ambient temperature limit	min/max °C	-5 / +55	-5 / +55	-5 / +55	-5 / +55	-5 / +55
Internal circuit protection degree	CE IP	55	55	55	--	--
	UL Type	--	--	--	12	12
External sound pressure	dB(A)	76	76	76	76	76
Height (A)	mm	780	780	780	780	780
Width (B)	mm	254	254	254	254	254
Depth (C)	mm	90	90	90	90	90
Installation		Internal / External	Internal	External	External	External
Machanic Thermostat		No	Yes	Yes	No	No
Weigth	kg	7,5	7,5	7,5	7,5	7,5

XVA50

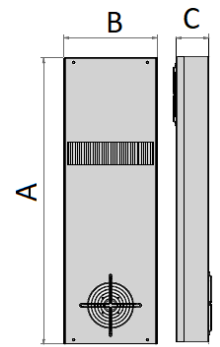
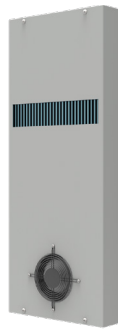

CODE	M.U.	XVA5000320	XVA50T0120	XVA50T0220	XVA50U1320	XVA50U1303
UL Listed		--	--	--	✓	✓
Rated Voltage	V, ~	230, 1	230, 1	230, 1	230, 1	115, 1
Nominal Frequency	Hz	50 60	50 60	50 60	50/60	60
Specific heat transmission	W/K	50	50	50	50	50
Current Consumption	A	0,46 0,58	0,46 0,58	0,46 0,58	0,8	1,4
Absorbed fan power	W	100 130	100 130	100 130	150	180
Internal operating Temp	min/max °C	-5 / +55	-5 / +55	-5 / +55	-5 / +55	-5 / +55
Ambient temperature limit	min/max °C	-5 / +55	-5 / +55	-5 / +55	-5 / +55	-5 / +55
Internal circuit protection degree	CE IP	55	55	55	--	--
	UL Type	--	--	--	12	12
External sound pressure	dB(A)	76	76	76	76	76
Height (A)	mm	780	780	780	780	780
Width (B)	mm	312	312	312	312	312
Depth (C)	mm	90	90	90	90	90
Installation		Internal / External	Internal	External	External	External
Machanic Thermostat		No	Yes	Yes	No	No
Weigth	kg	9,5	9,5	9,5	9,5	9,5

XVA80

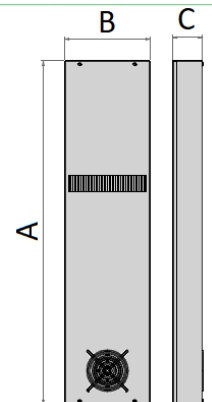

CODE	M.U.	XVA8000320	XVA80U1320	XVA80U1303
UL Listed		--	✓	✓
Rated Voltage	V, ~	230, 1	230, 1	115, 1
Nominal Frequency	Hz	50 60	50/60	60
Specific heat transmission	W/K	80	80	80
Current Consumption	A	0,72 0,96	1,3	2,3
Absorbed fan power	W	160 200	180	230
Internal operating Temp	min/max °C	-5 / +55	-5 / +55	-5 / +55
Ambient temperature limit	min/max °C	-5 / +55	-5 / +55	-5 / +55
Internal circuit protection degree	CE IP	55	--	--
	UL Type	--	12	12
External sound pressure	dB(A)	76	76	76
Height (A)	mm	1250	1250	1250
Width (B)	mm	311	311	311
Depth (C)	mm	108	108	108
Installation		Internal / External	External	External
Machanic Thermostat		No	No	No
Weigth	kg	20	20	20

XVAgo

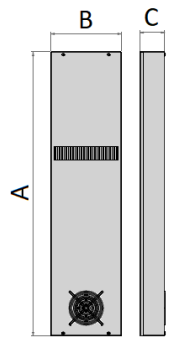
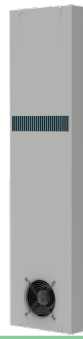

CODE	M.U.	XVAgoTo120		XVAgoTo220	
UL Listed		--		--	
Rated Voltage	V, ~	230, 1		230, 1	
Nominal Frequency	Hz	50	60	50	60
Specific heat transmission	W/K	85		85	
Current Consumption	A	1,1	1,5	1,1	1,5
Absorbed fan power	W	250	340	250	340
Internal operating Temp	min/max °C	-5 / +55		-5 / +55	
Ambient temperature limit	min/max °C	-5 / +55		-5 / +55	
Internal circuit protection degree	CE IP	55		55	
	UL Type	--		--	
External sound pressure	dB(A)	75		75	
Height (A)	mm	1250		1250	
Width (B)	mm	311		311	
Depth (C)	mm	108		108	
Installation		Internal		External	
Machanic Thermostat		Yes		Yes	
Weigth	kg	20		20	

Optional XVA

CODE	Special Colour	Stainless Steel AISI304 housing
XVA16	OCAXNS06	OCAXI01
XVA35	OCAXNS03	OCAXI02
XVA50	OCAXNS03	OCAXI02
XVA80	OCAXNS01	OCAXI03
XVA90	OCAXNS01	OCAXI03

Kryos³ - Indoor

New design, unaltered quality

Kryos³ GS filters fans, for the ventilation of electrical enclosures, are the optimal solution when the ambient temperature is lower than the temperature inside the cabinet, and can be installed, thanks to their reduced depth, on various types of panels.

Together with a new modern design, Kryos³ filter fans offer the same wide range of sizes and power supplies as previous generations, allowing you to choose the most suitable solution for your installation and geographical area.

With the Kryos³ product range, Cosmotec offers ventilation solutions that use ambient air to directly cool the enclosure while maintaining an adequate degree of protection from dust or water ingress (externally certified tests). The wide range of sizes and power supplies and the reduced depth allow the most suitable choice for the characteristics of the specific application.



User Friendly Installation

Easy to install without the use of tools or screws, thanks to the clips on the rear grille, which provide an adequate seal between the grille and the cabinet. The filter fans can be installed on different types of enclosures with thicknesses between 0.8 and 3 mm, for CNx10 between 0.8 and 2 mm. Fixing with screws is possible for larger thicknesses; each article is provided with embossments on the rear grille.

Main Features

- Easy opening for filter replacement/cleaning
- Screwless fixing system
- In ABS BLEND (RAL7035)
- Air Flow: 35 - 850 m³/h
- Suction/pressure fan orientation
- Protection Degree IP54
- MTBF: 40000 hours
- Certifications: CE, UL Recognized, UL Listed FFTA/FTTA7, CSA, EAC

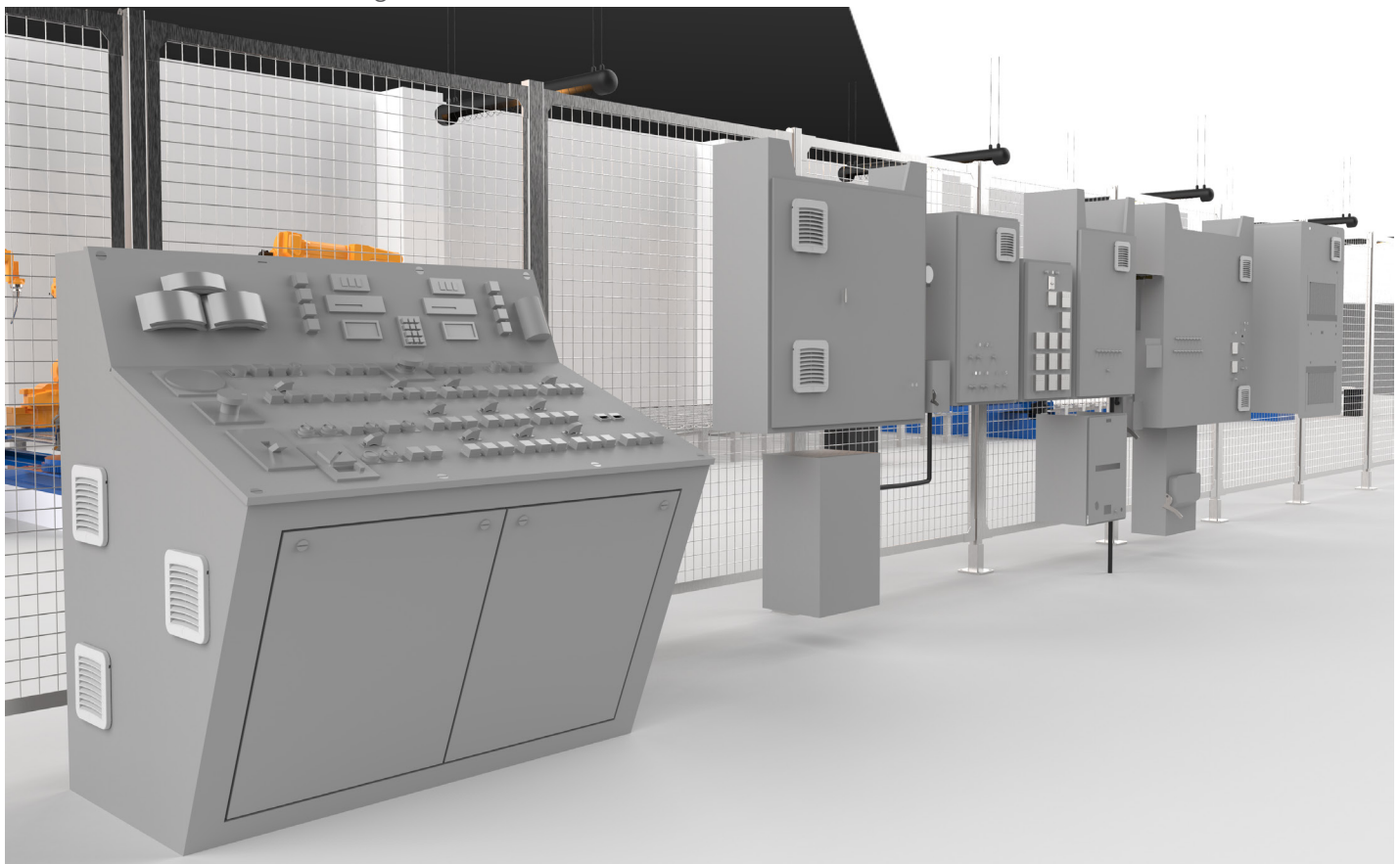

GSV10

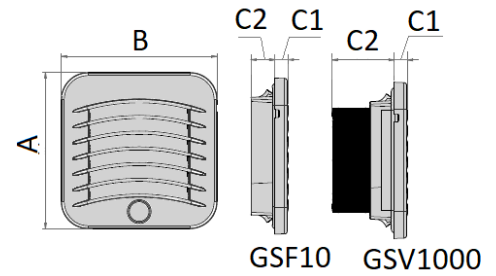

CODE	M.U.	GSF10	GSV1000220	GSV1000203	GSV1000211
UL Recognized - UL Listed FTTA/FTTA7		✓	✓	✓	✓
Rated Voltage	V, ~	--	230, 1	115, 1	24VDC
Nominal Frequency	Hz	--	50 60	50 60	--
Fan Flow GSV	m³/h	--	35	35	50
Fan Flow GSV+GSF10/GSF15	m³/h	--	24/27	24/27	32/38
Absorbed Power	W	--	4,6 4,5	3,6 2,86	6,3
Absorbed Current	A	--	0,21 0,205	0,22 0,175	0,265
Internal operating Temp. min/max	CE	°C	-10 / +70	-10 / +70	-10 / +70
	UL		-10 / +55	-10 / +55	-10 / +55
Protection Degree	CE	IP	54	54	54
	UL	Type	12	12	12
External Sound pressure	dB(A)	--	33	33	53
Height (A)	mm	119	119	119	119
Width (B)	mm	119	119	119	119
Depth (C1-C2)	mm	10,3 - 18,2	10,3 - 47,2	10,3 - 47,2	10,3 - 47,2

GSV15

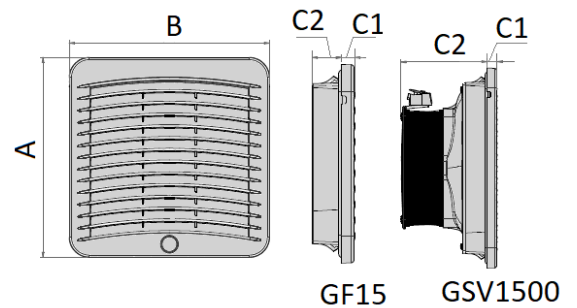

CODE	M.U.	GSF15	GSV1500220	GSV1500203	GSV1500211
UL Recognized - UL Listed FTTA/FTTA7		✓	✓	✓	✓
Rated Voltage	V, ~	--	230, 1	115, 1	24VDC
Nominal Frequency	Hz	--	50 60	50 60	--
Fan Flow GSV	m³/h	--	67	67	67
Fan Flow GSV+GSF15/GSF20	m³/h	--	50/58	50/58	50/58
Absorbed Power	W	--	22 22	22 25	8,1
Absorbed Current	A	--	0,14 0,14	0,26 0,3	0,335
Internal operating Temp. min/max	CE	°C	-10 / +70	-10 / +70	-10 / +70
	UL		-10 / +55	-10 / +55	-10 / +55
Protection Degree	CE	IP	54	54	54
	UL	Type	12	12	12
External Sound pressure	dB(A)	--	49	49	48
Height (A)	mm	152	152	152	152
Width (B)	mm	152	152	152	152
Depth (C1-C2)	mm	10,3 - 22,2	10,3 - 64,7	10,3 - 64,7	10,3 - 64,7

GSV20

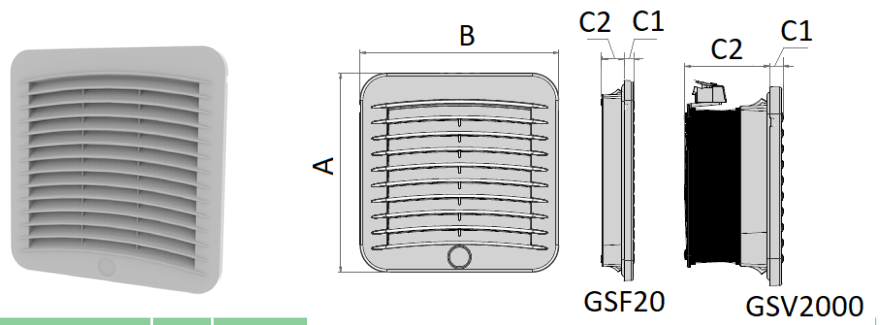

CODE	M.U.	GSF20	GSV2000220	GSV2000203	GSV2000211	
UL Recognized - UL Listed FTTA/FTTA7		✓	✓	✓	✓	
Rated Voltage	V, ~	--	230, 1	115, 1	24 VDC	
Nominal Frequency	Hz	--	50 60	50 60	--	
Fan Flow GSV	m³/h	--	108	108	108	
Fan Flow GSV+GSF20/GSF25	m³/h	--	75/88	75/88	75/88	
Absorbed Power	W	--	22 22	22 24,5	8,1	
Absorbed Current	A	--	0,14 0,14	0,26 0,29	0,335	
Internal operating Temp. min/max	CE	°C	-10 / +70		-10 / +70	
	UL		-10 / +55		-10 / +55	
Protection Degree	CE	IP	54	54	54	54
	UL	Type	12	12	12	12
External Sound pressure	dB(A)	--	49	49	48	
Height (A)	mm	204	204	204	204	
Width (B)	mm	204	204	204	204	
Depth (C1-C2)	mm	10,3 - 23,2	10,3 - 82,7	10,3 - 82,7	10,3 - 82,7	

GSV25

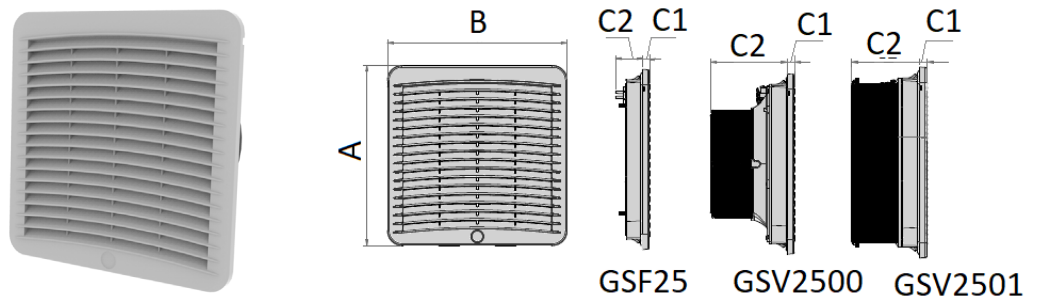

CODE	M.U.	GSF25	GSV2500220	GSV2500203	GSV2500211	GSV2501220	GSV2501203	
UL Recognized - UL Listed FTTA/FTTA7		✓	✓	✓	✓	✓	✓	
Rated Voltage	V, ~	--	230, 1	115, 1	24VDC	230, 1	115, 1	
Nominal Frequency	Hz	--	50 60	50 60	--	50 60	50 60	
Fan Flow GSV	m³/h	--	190	190	230	270	270	
Fan Flow GSV+GSF25/GSF30	m³/h	--	130/160	130/160	190/210	200/220	200/220	
Absorbed Power	W	--	25 70	39 38	26,6	50 66	50 75	
Absorbed Current	A	--	0,24 0,31	0,59 0,575	0,86	0,25 0,33	0,42 0,63	
Internal operating Temp. min/max	CE	°C	-10 / +70		-10 / +70		-10 / +70	
	UL		-10 / +55		-10 / +55		-10 / +55	
Protection Degree	CE	IP	54	54	54	54	54	
	UL	Type	12	12	12	12	12	
External Sound pressure	dB(A)	--	55	55	59	62	62	
Height (A)	mm	250	250	250	250	250	250	
Width (B)	mm	250	250	250	250	250	250	
Depth (C1-C2)	mm	10,3 - 37,2	10,3 - 102,2	10,3 - 102,2	10,3 - 102,2	10,3 - 88,2	10,3 - 88,2	

GSV30



CODE	M.U.	GSF30	GSV3000220	GSV3000203	GSV3001220
UL Recognized - UL Listed FTTA/FTTA7		✓	✓	✓	✓
Rated Voltage	V, ~	--	230, 1	115, 1	230, 1
Nominal Frequency	Hz	--	50 60	50 60	50 60
Fan Flow GSV	m³/h	--	500	500	700
Fan Flow GSV+GSF30/2xGSF30	m³/h	--	380/450	380/450	600/670
Absorbed Power	W	--	50 63	50 72	115 173
Absorbed Current	A	--	0,25 0,315	0,42 0,61	0,51 0,77
Internal operating Temp. min/max	CE °C	--	-10 / +60	-10 / +60	-10 / +55
	UL °C	--	-10 / +55	-10 / +55	-10 / +55
Protection Degree	CE IP	54	54	54	54
	UL Type	12	12	12	12
External Sound pressure	dB(A)	--	62	62	65
Height (A)	mm	318	318	318	318
Width (B)	mm	318	318	318	318
Depth (C1-C2)	mm	10,3 - 23,2	10,3 - 128,7	10,3 - 128,7	10,3 - 128,2

CODE	M.U.	GSV3001203	GSV3002220	GSV30002203	GSV3002262
UL Recognized - UL Listed FTTA/FTTA7		✓	✓	✓	✓
Rated Voltage	V, ~	115, 1	230, 1	115, 1	400,3 460,3
Nominal Frequency	Hz	50 60	50 60	50 60	50 60
Fan Flow GSV	m³/h	700	850	850	850
Fan Flow GSV+GSF30/2xGSF30	m³/h	600/670	620/670	620/700	620/700
Absorbed Power	W	125 170	142 182	115 196	115 204
Absorbed Current	A	1,1 1,5	0,63 0,81	1,02 1,24	0,23 0,355
Internal operating Temp. min/max	CE °C	-25 / +50	-25 / +55	-25 / +55	-25 / +60
	UL °C	-25 / +55	-25 / +55	-25 / +55	-25 / +55
Protection Degree	CE IP	54	54	54	54
	UL Type	12	12	12	12
External Sound pressure	dB(A)	68	65	71	65
Height (A)	mm	318	318	318	318
Width (B)	mm	318	318	318	318
Depth (C1-C2)	mm	10,3 - 128,7	10,3 - 150,2	10,3 - 150,2	10,3 - 150,2

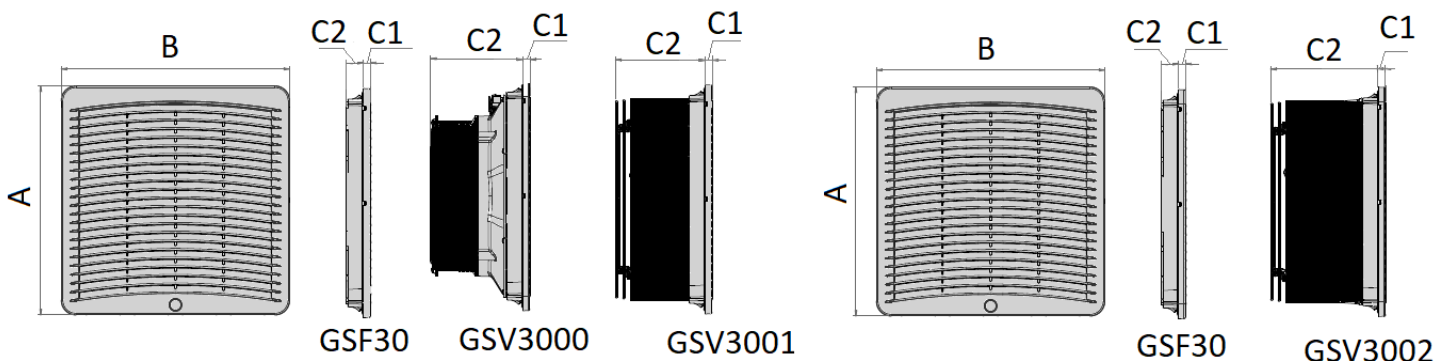

Spare Air Filter

CODE	10 Filters
GSF10	AVAFAGS10
GSF15	AVAFAGS15
GSF20	AVAFAGS20
GSF25	AVAFAGS25
GSF30	AVAFAGS30
GSV10	AVAFAGS10
GSV15	AVAFAGS15
GSV20	AVAFAGS20
GSV25	AVAFAGS25
GSV30	AVAFAGS30

Features

- Material = chemical fibers
- Weight 200 g/m²
- Thickness 14 mm
- Dust holding capacity 600g/m²
- IP54



Additional Air Filter Protection Degree IP55

CODE	5 filters Package
GSF15-GSV15	AVAFLGS15
GSF20-GSV20	AVAFLGS20
GSF25-GSV25	AVAFLGS25
GSF30-GSV30	AVAFLGS30

Features

- Material = chemical fibers
- Weight 200 g/m²
- Thickness 7 mm
- Dust holding capacity 597g/m²

Installation technical notes in the manual

Hose-proof hood IP56 Protection Degree

CODE	1 Hose-proof hood	Dimensions
GSF10	AVAFSGS10	231 x 150 x 30,7
GSF15	AVAFSGS15	246 x 176 x 45,7
GSF20	AVAFSGS20	331 x 233 x 45,7
GSF25	AVAFSGS25	392,5 x 282 x 75,7
GSF30	AVAFSGS30	482,5 x 350 x 100,7
GSV10	AVAFSGS10	231 x 150 x 30,7
GSV15	AVAFSGS15	246 x 176 x 45,7
GSV20	AVAFSGS20	331 x 233 x 45,7
GSV25	AVAFSGS25	392,5 x 282 x 75,7
GSV30	AVAFSGS30	482,5 x 350 x 100,7

Features

- Material = galvanised sheet
- Option = AISI304 Stainless Steel



KryosROOF - Indoor

New design, more flexibility

KryosRoof roof mounted fans are the ideal industrial ventilation solution for extracting warm air from the roof. Their compact dimensions allow them to be installed on various types of electrical panels, while the layout and fans ensure high flow rates and operating efficiency. The TSF/TSV feature a new design, compact dimensions and the flexibility properties typical of Cosmotec products.

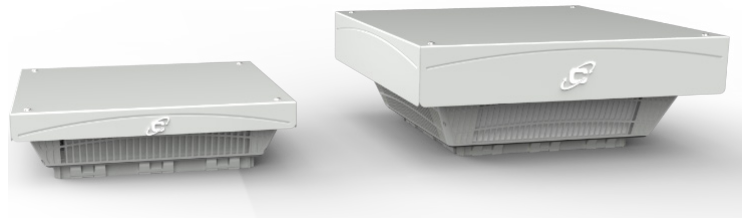

Performance and Efficiency

The radial fans on KryosROOF provide high flow rates and heads to ensure the correct airflow within the cabinet. In addition, there is a high efficiency version with EC fans and an **active control probe**, supplied as standard, which adjusts the fan speed to reduce electricity consumption and ensure optimum air flow according to the temperatures in the electrical panel. Electrical consumption can already be **reduced by 20/30%** at maximum operating conditions.

Energy efficiency eliminates energy waste and generates savings that last. Rational use of energy and investment in energy-efficient technological solutions increase the profitability of operations and make them more competitive, modern and efficient. Improving the energy efficiency of production processes helps to reduce fixed production costs, increase the market value of the product and reduce environmental impact. KryosROOF extraction towers **regulate the air flow** optimally for each operating condition and heat load.

Main Features

- ABS Blend base and galvanised sheet metal cover
- Screwless fixing system
- Air Flow: 500...1870 m³/h
- Version without fan available
- Protection Degree: IP43/Type1 - IP54/Type12
- MTBF: 40000 hours
- RADial fans with minimum pressure losses
- Certifications: CE, UL Recognized, UL Listed, EAC



TSF/TSV19

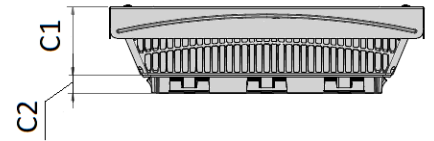
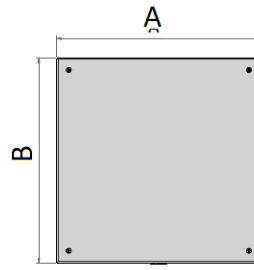

CODE	M.U.	TSF19U0 20000000	TSF19U1 20000000	TSV19U0 22000000	TSV19U1 22000000	TSV19U0 20300000	TSV19U1 20300000
UL Recognized - UL Listed FTTA/FTTA7		✓	✓	✓	✓	✓	✓
Rated Voltage	V, ~	--	--	230,1	230,1	115,1	115,1
Nominal Frequency	Hz	--	--	50/60	50/60	60	60
Fan Flow TSV	m³/h	--	--	540/575	500/535	555	515
Fan Flow TSV+GSF30	m³/h	--	--	460/495	420/455	475	435
Absorbed Power	W	--	--	52/65	52/65	70	70
Absorbed Current	A	--	--	0,21/0,29	0,21/0,29	0,61	0,61
Internal operating Temp.	min/ max °C	-40/+60	-40/+60	-25/+55	-25/+55	-25/+55	-25/+55
Protection Degree	CE IP	43	54	43	54	43	54
	UL Type	1	12	1	12	1	12
External Sound pressure	dB(A)	--	--	53	53	53	53
Height (A)	mm	395	395	395	395	395	395
Width (B)	mm	395	395	395	395	395	395
Depth (C)	mm	108	108	112	112	112	112

TSV22

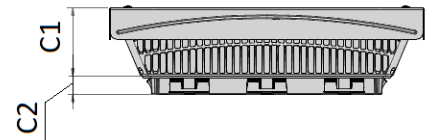
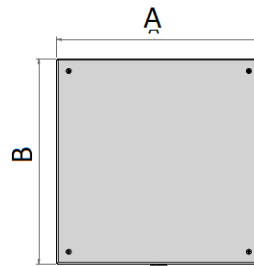
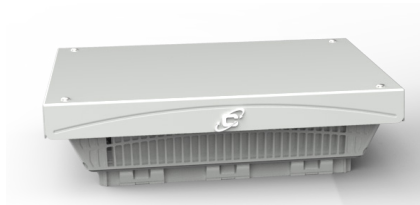

CODE	M.U.	TSV22U0 22000000	TSV22U1 22000000	TSV2200 22010000	TSV2201 22010000	TSV22U0 20300000	TSV22U1 20300000
UL Recognized - UL Listed FTTA/FTTA7		✓	✓	--	--	✓	✓
Rated Voltage	V, ~	230,1	230,1	200...240,1	200...240,1	115,1	115,1
Nominal Frequency	Hz	50/60	50/60	50/60	50/60	60	60
Fan Flow TSV	m³/h	800/810	715/725	925	840	785	710
Fan Flow TSV+GSF30	m³/h	615/625	530/540	720	635	600	525
Absorbed Power	W	88/116	88/116	85	85	108	108
Absorbed Current	A	0,37/0,49	0,37/0,49	0,7	0,7	0,9	0,9
Internal operating Temp.	min/ max °C	-25/+55	-25/+55	-25/+55	-25/+55	-25/+55	-25/+55
Protection Degree	CE IP	43	54	43	54	43	54
	UL Type	1	12	--	--	1	12
External Sound pressure	dB(A)	54	52	56	54	54	52
Height (A)	mm	395	395	395	395	395	395
Width (B)	mm	395	395	395	395	395	395
Depth (C)	mm	112	112	112	112	112	112

TSF/TSV25

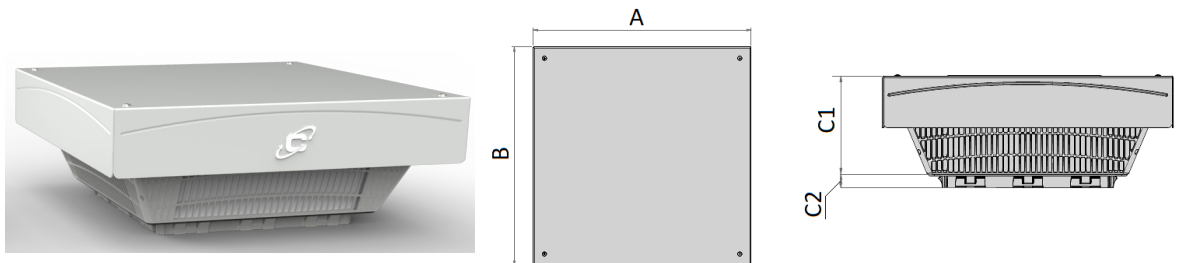

CODE	M.U.	TSF25U0 20000000	TSF25U1 20000000	TSV25U0 22000000	TSV25U1 22000000	TSV25U0 20300000	TSV25U1 20300000
UL Recognized - UL Listed FTTA/FTTA7		✓	✓	✓	✓	✓	✓
Rated Voltage	V, ~	--	--	230,1	230,1	115,1	115,1
Nominal Frequency	Hz	--	--	50/60	50/60	60	60
Fan Flow TSV	m³/h	--	--	1425/1520	1365/1480	1470	1420
Fan Flow TSV+2xGSF30	m³/h	--	--	1310/1405	1250/1365	1355	1305
Absorbed Power	W	--	--	230/340	230/340	300	300
Absorbed Current	A	--	--	0,85/1,15	0,85/1,15	2,5	2,5
Internal operating Temp.	min/ max °C	-40/+60	-40/+60	-25/+55	-25/+55	-25/+55	-25/+55
Protection Degree	CE IP	43	54	43	54	43	54
	UL Type	1	12	1	12	1	12
External Sound pressure	dB(A)	--	--	63	62	63	62
Height (A)	mm	490	490	490	490	490	490
Width (B)	mm	490	490	490	490	490	490
Depth (C)	mm	188	188	191	191	191	191

TSV35

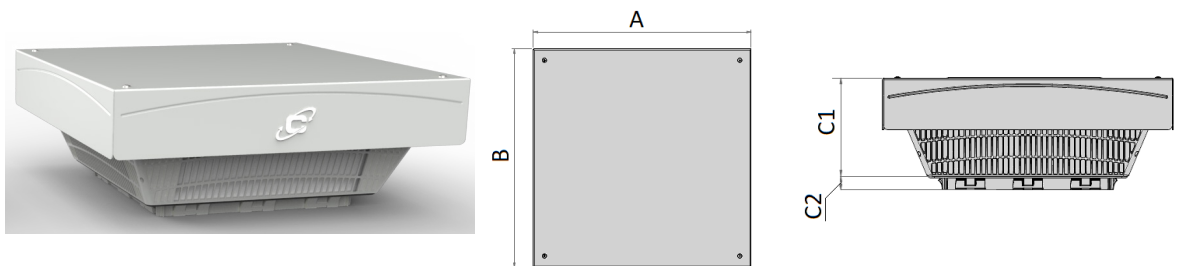

CODICE	M.U.	TSV35U0 22000000	TSV35U1 22000000	TSV3500 22010000	TSV3501 22010000
UL Recognized - UL Listed FTTA/FTTA7		✓	✓	--	--
Rated Voltage	V, ~	230,1	230,1	200...240,1	200...240,1
Nominal Frequency	Hz	50/60	50/60	50/60	50/60
Fan Flow TSV	m³/h	1870	1700	1870	1700
Fan Flow TSV+3xGSF30	m³/h	1520	1350	1520	1350
Absorbed Power	W	168	168	168	168
Absorbed Current	A	1,4/1,4	1,4/1,4	1,4	1,4
Internal operating Temp.	min/ max °C	-25/+55	-25/+55	-25/+55	-25/+55
Protection Degree	CE IP	43	54	43	54
	UL Type	1	12	--	--
External Sound pressure	dB(A)	57	57	57	57
Height (A)	mm	490	490	490	490
Width (B)	mm	490	490	490	490
Depth (C)	mm	191	191	191	191

Optional KryosROOF TSV

CODE	Spacial Colour	Stainless Stell 316 housing
TSF/TSV19	OCAXNS12 (1)	AVAIN01 (1)
TSF/TSV22	OCAXNS12 (1)	AVAIN01 (1)
TSF/TSV25	OCAXNS12 (1)	AVAIN02 (1)
TSF/TSV35	OCAXNS12 (1)	AVAIN02 (1)

(1) Only Cover

Heaters

Heaters are useful to avoid too much condensate water into the switchgear or an excessively low temperature. The heaters are made of aluminum to maximize heat transfer and utilize PTC heating elements.

- Suitable for installation on 35mm DIN rails,
- With fan in TH version
- To be used in combination with a thermostat or hygrostat
- Certifications: CE



CODE	M.U.	EH020	EH030	EH050	FH101	FH151	TH150	TH300	TH450	TH600
Heating capacity	W	20	30	50	100	150	150	300	450	600
Power Supply	V	110 - 230	110 - 230	110 - 230	110 - 230	110 - 230	230	110 - 230	110 - 230	110 - 230
Max Current	A	1.0 - 1.5	1.0 - 1.5	1.0 - 1.5	3.0 - 3.5	5.0 - 6.0	5.0 - 6.0	8.0 - 10.0	8.0 - 10.0	9.0 - 12.0
Fuse		2	2	2	2	4	4	4	4	6
Dimensions	mm	124x41x41	124x41x41	150x41x41	144x62x87	170x62x87	145x41x51	115x80x96	140x80x96	140x80x96
Weight	kg	0,2	0,2	0,3	0,55	0,7	0,5	0,65	0,75	0,9
Connection Type		terminal board	terminal board	terminal board	spring terminal	spring terminal	terminal board	spring terminal	spring terminal	spring terminal

Thermostats

Devices for cabinet temperature control, with DIN bar installation.

TMF (blue setting screw) = with normally open contact. It can be used for signalling temperature alarms or for controlling ventilation systems.

TMC (red setting screw) = with normally closed contact. Can be used either as an alarm signal or to control heating or anti-condensation heaters.

TEM = to be electrically powered, differs from the previous ones in that it has changeover contacts, a very low tripping differential or hysteresis.



Certifications: CE

CODE	M.U.	TMC	TMF	TEM
Temperature Range	°C	-10 / +80	-10 / +80	+5 / +60
Power Supply	V	110 - 230	110 - 230	230
Dimensions	mm	71 x 35 x 47	71 x 35 x 47	65 x 50 x 61
Switching contact resistive load opening/closing	A	10	10	10 / 5
Accuracy	°C	± 3	± 3	± 1
Thermal Gradient	°C	1	1	1
ON/OFF Differential temperature	K	- 3	- 3	0,5
Contacts	n°	2	2	3
Contacts Position	-	NC	NO	NC / NO
Protection Degree	IP	20	20	20
Weight	g	36	36	100
Electrical Connections	n x Ø	2 x 2,5 mm	2 x 2,5 mm	4 x 2,5 mm
Fixing system	-	DIN 35/15	DIN 35/15	DIN 35

Protection Degree Classification

IP classification

¹ digit	Protection from solid foreign objects	² digit	Protection against water ingress
0	No protection	0	No protection
1	Protection against the penetration of solid foreign objects with a diameter ≥ 50 mm	1	Protection against dripping water
2	Protection against the penetration of solid foreign objects with a diameter $\geq 12,5$ mm	2	Protection against dripping water when tilted up to 15°
3	Protection against the penetration of solid foreign objects with a diameter $\geq 2,5$ mm	3	Protection against spraying water
4	Protection against the penetration of solid foreign objects with a diameter ≥ 1 mm	4	Protection against splashing of water
5	Dust protection	5	Protection against water jets
6	Dust-tight	6	Protection against powerful water jets

NEMA ratings

TYPE	
4	For indoor or outdoor use, protected against windblown dust, rain, splashing water and sprayed water; also protected against external formation of ice on the enclosure
4X	Enclosures constructed for indoor or outdoor use protected against windblown dust and rain, splashing water, sprayed water and corrosion; also protected against external formation of ice on the enclosure
12	Enclosures constructed for indoor use protected against falling dirt, circulating dust and dripping, non-corrosive liquids

COSMOTEC

Industrial Cooling

STULZ S.p.A.

Via E. Torricelli 3
37067 Valeggio sul Mincio (VR)

Tel. +39 045.6331600

Fax +39 045.6331635

STULZ S.p.A. reserves the right to update the characteristics of the products (data/drawings) without notice. Any modification or print error won't entitle the reader to disputes.

REV 26 / 04-2023

WWW.COSMOTEC.IT
info@cosmotec-cooling.com