

EMP Surge Protector/Filter for AC / DC Power Supplies USS-2-48V

Excellent lightning and EMP protection of an earth-free and short-circuit current limited AC or DC power supply line pair up to max. 48 V / 6 A

Protects against overvoltages produced by NEMP / HEMP, lightning or other transients

High nominal operating current of 6 A

Multi-stage protection/filter design providing high transient energy absorption capability

Feed-through type steel body for direct installation to wall of Faraday cage

Threat-level tested against HEMP according to MIL-STD-188-125, short and medium

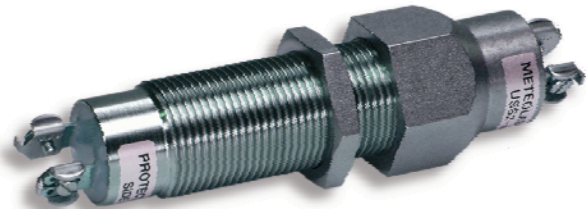

Product

The Meteolabor® USS-2 series protection circuits against surge and interference voltages are designed as feed-through type mechanical units for the protection of data and control line systems. Depending on the specific application different types are available.

The highly effective multi-stage transient protection design combined with filtering components provides excellent protection against the effects of atmospheric discharges (lightning, electrostatic discharge) or a High Altitude Electro-Magnetic Pulse (HEMP), sometimes also referred to as Nuclear Electro-Magnetic Pulse (NEMP) or simply EMP. Special features of this series of protection circuits include high surge current capability, compact feed-through design and simple installation directly to Faraday cage. The USS-2-Series is threat-level tested against EMP according to MIL-STD-188-125, short pulse and intermediate pulse.

Applications

The Meteolabor® USS-2-48V overvoltage protector/filter is intended to protect earth-free AC or DC power supply lines, which are short-circuit current limited to < 0.5 A (or fused) against overvoltage effects caused by NEMP / HEMP or lightning strikes. For reliable extinction of gas tube arrestors it is very important, that the short-circuit current of the power feeding source is fused with 6A or less, or the short circuit current must be limited to less than 0.5A.

The USS-2-48V is also suitable to protect power supply lines of PoE (Power over Ethernet) circuits within 10/100 Mbit/s Ethernet applications. This is done in combination with the USS-2-AQ (NSN listed) Ethernet protector.

USS-2-48V has been used in many fixed installations (buildings, underground shelters etc.) as well as in portable and mobile systems like containers or shelters and vehicles, which were successfully EMP-tested according to RS105 of MIL-STD-461F.

Technical Data USS-2-48V

Application	Low voltage power	Source and load must be earth-free and short-circuit current limited
Maximum operating voltage U_{Max}	± 48 V DC / 32 V AC	
Nominal operating current I_N	6 A	$T_{amb} = 40$ °C, short-circuit current must be limited to < 0.5 A or fused 6A or less for safe extinction of gas tube arrester
DC resistance	2 x 40 m Ω	
Max. surge current I_{Max}	2 x 10 kA	wire → ground/case, shape 8/20 μ s, $T_{amb} = 40$ °C
Max. lightning impulse current I_{Imp}	2x2 kA	Each wire → ground/case, shape 10/350 μ s, at least 1 pulse
Residual voltage	< 110 V	wire → wire, worst case, depending on pulse shape
Residual voltage	< 700 V	wire → ground/case, worst case, depending on pulse shape
Average common mode attenuation	typ. 50 dB	at 50 Ω , up to 2.4 GHz
DC earth leakage current	< 1 μ A	at U_{Max} , $T_{amb} = 40$ °C
Operating temperature range	- 40 °C / + 85 °C	
Connection terminals	2.8 / 6.3 mm	Choice of FASTON flat receptacle, solder or screw connection
Max. allowed installation torque	25 Nm	Not to be exceeded under all circumstances
Dimensions (Overall)	113 x 31.2 x 27 mm	Major dimensions, details see drawing
Weight	approx. 180 g	

Dimensions

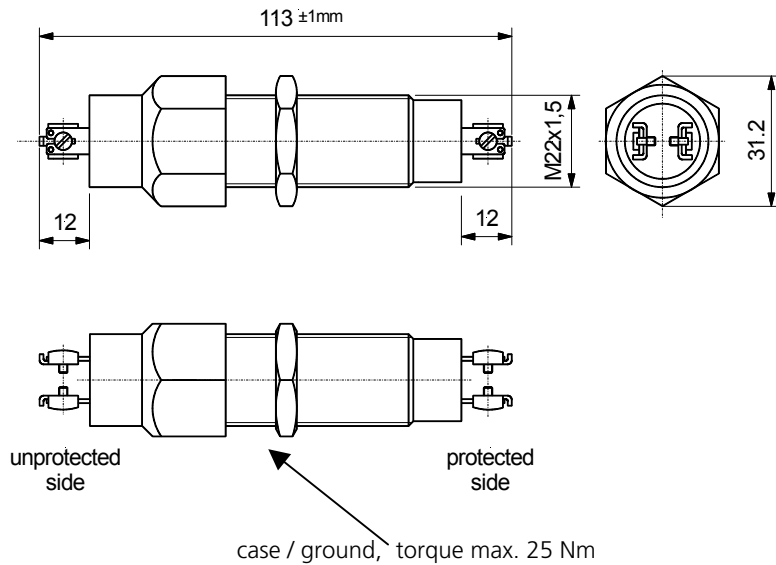

Installation Layouts

Standard drilling layout for USS-2 series with standard hexagonal nut (included, spanner size 27mm)

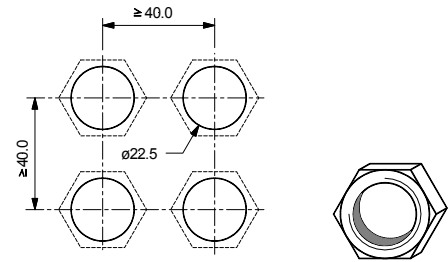

Space saving "honeycomb" mounting hole layout for USS-2 series (requires optional slotted nut USS-SM2 and USS-SK2 spanner)

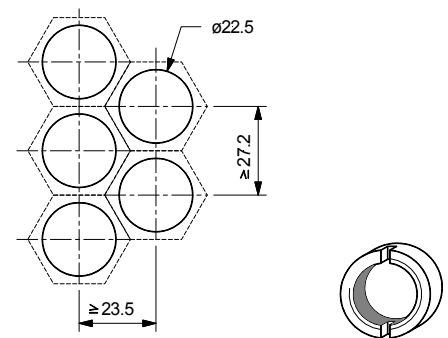

Installation Instructions

- The USS-2 series EMP protector/filters shall be installed by electrically skilled personnel.
- The electrical wiring must be done according to local regulations.
- The max. values stated in this datasheet must not be exceeded under any circumstances.
- Do not exceed max. installation torque of 25 Nm as this can destroy the device.
- USS-2 series EMP protector/filters may be directly installed into the wall of a Faraday cage as feed-through device. Otherwise the cabling on the protected side must be shielded for best performance.
- For space-saving installation of multiple protectors a "honeycomb" layout is recommended (see drawings).

General Recommendations for Protection Installation

- In order to achieve the full performance of a protection circuit the application of good-practice EMC design techniques is necessary for the whole system to be protected.
- For EMP-protection usually a shield as an electromagnetic barrier to protect a certain volume is necessary. This shield avoids coupling of radiated disturbances inside the protected volume. In addition to shielding all penetrating wires must be protected from conducted transient interferences by an appropriate POE (point of entry) protection.
- Use tested, high quality POE (point of entry) protection elements for all wires entering an electromagnetic shield and install these as feed-through devices, e.g. the Meteolabor® USS-1, USS-2, USP, CSP or PLP series.

Ordering Information / Part Number

USS-2-48V Surge protector/filter EMP USS2-48V

USS-SM2 optional slotted nut

USS-SK2 optional special socket spanner for slotted nut



Caution

Maximum torque for installation screw shall not exceed 25 Nm