



**finder**<sup>®</sup>  
SWITCH TO THE FUTURE

# Switch mode power supplies

**78**  
SERIES



Building automation



Elevators and lifts



Automation for blinds, grilles and shutters



Hoists and cranes



Panels for electrical distribution



Pump Control



**12 W Low profile Modular DC Power Supplies for electrical cabinets**

**Type 78.12....2400**

- Output 24 V DC, 12 W
- 17.5 mm (1 module) x 61 mm deep

**Type 78.12....1200**

- Output 12 V DC, 12 W
- 17.5 mm (1 module) x 61 mm deep

- Low (< 0.4 W) stand-by power consumption
- Thermal protection: internal, with V<sub>out</sub> shutdown - power OFF to reset
- Short circuit protection: Hiccup (auto-recovery) mode
- Overvoltage protection: Varistor
- Flyback topology
- Compliant with EN 60950-1 and EN 61204-3
- Parallel working for automatic redundancy - with OR diodes
- Dual Polarity and Series connection permissible
- 35 mm rail (EN 60715) mount

Screw terminal



For outline drawing see page 25

**Output specification**

Output current (-20...+40 °C, 230 V AC input)	A	0.63	1.25
Rated current I <sub>N</sub> (50 °C, full input operating range)	A	0.50	1
Rated voltage	V	24	12
Rated power	W	12	12
Output power (-20...+40 °C, 230 V AC input)	W	15	15
Peak current capability for 3 ms*	A	2	3
Output voltage adjust	V	—	—
Voltage variation (from no-load to full-load)		< 1%	< 1%
Voltage ripple @ full load**	mV	< 200	< 200
Hold-up time @ full load:	with 100 V AC input ms	> 10	> 10
	with 260 V AC input ms	> 90	> 90

**Input specification**

Nominal voltage (U <sub>N</sub> )	V AC (50/60 Hz)	110...240	110...240
	V DC (not polarized)	220	220
Operating range	V AC (50/60 Hz)	100...265***	100...265***
	V DC	140...370	140...370
Max power consumption (@ 100 V AC, 50 Hz)	VA	28.2	32
	W	14.2	17.2
Stand-by power consumption	W	< 0.4	< 0.4
Power factor		0.50	0.53
Max current consumption (@ 88 V AC)	A	0.25	0.30
Max. inrush current (peak @ 265 V) for 3 ms	A	10	10
Replaceable input fuse		—	—

**Technical data**

Efficiency (@ 230 V AC)	%	85	87
MTTF	h	> 400 · 10 <sup>3</sup>	> 400 · 10 <sup>3</sup>
Start-up delay	s	< 1	< 1
Dielectric strength between input/output	V AC	2500	2500
Dielectric strength between input/PE	V AC	—	—
Ambient temperature range****	°C	-20...+60	-20...+60
Protection category		IP 20	IP 20

**Approvals** (according to type)



• 24 V DC, 12 W output



• 12 V DC, 12 W output

\* (see diagrams P78)

\*\* peak to peak, 100 Hz component, with 100 V AC input

\*\*\* 88...100 V AC with output current limited to 80% I<sub>N</sub>

\*\*\*\* (see derating diagrams L78)

**25 W Low profile Modular DC Power Supplies for electrical cabinets**

- Type 78.25....2400**
- Output 24 V DC, 25 W
  - 35 mm (2-module) x 61 mm deep
- Type 78.25....1200**
- Output 12 V DC, 25 W
  - 35 mm (2-module) x 61 mm deep
- Low (< 0.4 W) stand-by power consumption
  - Thermal protection: internal, with V<sub>out</sub> shutdown - power OFF to reset
  - Short circuit protection: Hiccup (auto-recovery) mode
  - Overvoltage protection: Varistor
  - Flyback topology
  - Compliant with EN 60950-1 and EN 61204-3
  - Parallel working for automatic redundancy - with OR diodes
  - Dual Polarity and Series connection permissible
  - 35 mm rail (EN 60715) mount

Screw terminal



**78.25....2400**



• 24 V DC, 25 W output

**78.25....1200**



• 12 V DC, 25 W output

\* (see diagrams P78)  
 \*\* peak to peak, 100 Hz component, with 100 V AC input  
 \*\*\* 88...100 V AC with output current limited to 80% I<sub>N</sub>  
 \*\*\*\* (see derating diagrams L78)

For outline drawing see page 25

Output specification		
Output current (-20...+40 °C, 230 V AC input)	A	1                      2.1
Rated current I <sub>N</sub> (50 °C, full input operating range)	A	0.75                      1
Rated voltage	V	24                      12
Rated power	W	25                      25
Output power (-20...+40 °C, 230 V AC input)	W	25                      25
Peak current capability for 3 ms*	A	3                      4
Output voltage adjust	V DC	—                      —
Voltage variation (from no-load to full-load)		< 1%                      < 1%
Voltage ripple @ full load**	mV	< 200                      < 200
Hold-up time @ full load: with 100 V AC input ms		> 40                      > 40
with 260 V AC input ms		> 100                      > 100
Input specification		
Nominal voltage (U <sub>N</sub> )	V AC (50/60 Hz)	110...240                      110...240
	V DC (not polarized)	220                      220
Operating range	V AC (50/60 Hz)	100...265***                      110...265***
	V DC	140...370                      140...370
Max power consumption (@ 100 V AC, 50 Hz)	VA	56.4                      56
	W	27.5                      27.3
Stand-by power consumption	W	≤ 0.5                      ≤ 0.30
Power factor		0.50                      0.50
Max current consumption (@ 88 V AC)	A	0.43                      0.43
Max. inrush current (peak @ 265 V) for 3 ms	A	20                      20
Replaceable input fuse		—                      —
Technical data		
Efficiency (@ 230 V AC)	%	89                      89
MTTF	h	> 400 · 10 <sup>3</sup> > 400 · 10 <sup>3</sup>
Start-up delay	s	< 1                      < 1
Dielectric strength between input/output	V AC	2500                      2500
Dielectric strength between input/PE	V AC	—                      —
Ambient temperature range****	°C	-20...+60                      -20...+60
Protection category		IP 20                      IP 20

Approvals (according to type)



**36 W, 60 W and 50 W High efficiency, low profile Modular DC Power Supplies for electrical cabinets**

- Type 78.36**
- Output 24 V DC, 36 W
  - Input fuse: Easily replaceable plus spare
  - 70 mm (4-module) wide x 61 mm deep
- Type 78.60**
- Output 24 V DC, 60 W
- Type 78.50**
- Output 12 V DC, 50 W
- High efficiency (up to 91%)
  - Low (< 0.4 W) stand-by power consumption
  - Thermal protection: internal, with V<sub>out</sub> shutdown - power OFF to reset
  - Short circuit protection: Hiccup (auto-recovery) mode
  - Input fuse: Easily replaceable plus spare
  - Overvoltage protection: Varistor
  - Flyback topology
  - ZVS (Zero-voltage-switching), quasi-resonant mode switching
  - Compliant with EN 60950-1 and EN 61204-3
  - Parallel working for automatic redundancy - with OR diodes
  - Dual Polarity and Series connection permissible
  - Compact dimensions: 70 mm (4-modules) wide, 61 mm deep
  - 35 mm rail (EN 60715) mount

Screw terminal



For outline drawing see page 25

Output specification			
Output current (-20...+40 °C, 230 V AC input)	A	1.7                      2.8                      4.6	
Rated current I <sub>N</sub> (50 °C, input (100...265)V AC - (140...370)V DC)	A	1.5                      2.5                      4.2	
Rated voltage	V	24                      24                      12	
Rated power	W	36                      60                      50	
Output power (-20...+40 °C, 230 V AC input)	W	40                      68                      55	
Peak current capability for 3 ms*	A	8                      10                      12	
Output voltage adjust	V	—                      24...28                      12...14	
Voltage variation (from no-load to full-load)		< 1%                      < 1%                      < 1%	
Voltage ripple @ full load**	mV	< 200                      < 200                      < 200	
Hold-up time @ full load: with 100 V AC input ms		> 20                      > 20                      > 30	
	with 260 V AC input ms	> 100                      > 130                      > 150	
Input specification			
Nominal voltage (U <sub>N</sub> )	V AC (50/60 Hz)	110...240                      110...240                      110...240	
	V DC (not polarized)	220                      220                      220	
Operating range	V AC (50/60 Hz)	100...265***                      88...265                      88...265	
	V DC	140...370                      140...370                      140...370	
Max power consumption (@ 100 V AC, 50 Hz)	VA	57.5                      90                      89	
	W	43                      67.5                      58.3	
Stand-by power consumption	W	< 0.4                      < 0.4                      < 0.4	
Power factor		0.74                      0.75                      0.65	
Max current consumption (@ 88 V AC)	A	0.6                      0.9                      0.85	
Max. inrush current (peak @ 265 V) for 3 ms	A	12                      30                      30	
Replaceable input fuse		1 A - T                      1.6 A - T                      1.6 A - T	
Technical data			
Efficiency (@ 230 V AC)	%	86                      91                      90	
MTTF	h	> 600 · 10 <sup>3</sup> > 500 · 10 <sup>3</sup> > 400 · 10 <sup>3</sup>	
Start-up delay	s	< 1                      < 1                      < 1	
Dielectric strength between input/output	V AC	3000                      3000                      3000	
Dielectric strength between input/PE	V AC	—                      1500                      1500	
Ambient temperature range****	°C	-20...+70                      -20...+70                      -20...+70	
Protection category		IP 20                      IP 20                      IP 20	

Approvals (according to type)



**78.36**



• 24 V DC, 36 W output

**78.60**

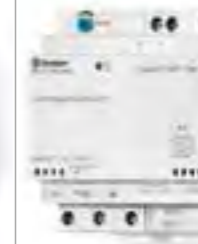

• 24 V DC, 60 W output  
 • Output adjustable between 24-28 V  
 • ZVS technology

**78.50**



• 12 V DC, 50 W output  
 • Output adjustable between 12-14 V  
 • ZVS technology

Replaceable fuse + spare



\* (see diagrams P78)  
 \*\* peak to peak, 100 Hz component, with 100 V AC input  
 \*\*\* 88...100 V AC with output current limited to 80% I<sub>N</sub>  
 \*\*\*\* (see derating diagrams L78)

**60 W and 50 W High efficiency, low profile Modular DC Power Supplies for electrical cabinets**

**Fold-Back overload characteristics for Battery charging applications and parallel working for increased load current**

**Type 78.61**  
- Output 24 V DC, 60 W

**Type 78.51**  
- Output 12 V DC, 50 W

- High efficiency (up to 91%)
- Low (< 0.4 W) stand-by power consumption
- Thermal protection: internal, with V<sub>out</sub> shutdown - power OFF to reset
- Short circuit protection: Hiccup (auto-recovery) mode
- Overload protection: Fold-back mode
- Input fuse: Easily replaceable plus spare
- Overvoltage protection: Varistor
- Flyback topology
- ZVS (Zero-voltage-switching), quasi-resonant mode switching
- Compliant with EN 60950-1 and EN 61204-3
- Parallel working for increased load current (with OR diodes)
- Dual Polarity and Series connection permissible
- Compact dimensions: 70 mm (4-modules) wide, 60 mm deep
- 35 mm rail (EN 60715) mount

Screw terminal



For outline drawing see page 25

**Output specification**

Output current (-20...+40 °C, 230 V AC input)	A	2.6	4.6
Rated current I <sub>N</sub> (50 °C, input (100...265)V AC - (140...370)V DC)	A	2.5	4.2
Rated voltage	V	24	12
Rated power	W	60	50
Output power (-20...+40 °C, 230 V AC input)	W	68	55
Peak current capability for 3 ms*	A	8	12
Output voltage adjust	V	24...28	12...15
Voltage variation (from no-load to full-load)		< 1%	< 1%
Voltage ripple @ full load**	mV	< 200	< 200
Hold-up time @ full load: with 100 V AC input ms		> 20	> 30
with 260 V AC input ms		> 130	> 150

**Input specification**

Nominal voltage (U <sub>N</sub> )	V AC (50/60 Hz)	110...240	110...240
	V DC (not polarized)	220	220
Operating range	V AC (50/60 Hz)	88...265	88...265
	V DC	140...370	140...370
Max power consumption (@ 100 V AC, 50 Hz)	VA	90	89
Stand-by power consumption	W	< 0.4	< 0.4
Power factor		0.75	0.65
Max current consumption (@ 88 V AC)	A	0.9	0.85
Max. inrush current (peak @ 265 V) for 3 ms	A	30	30
Replaceable input fuse		1.6 A - T	1.6 A - T

**Technical data**

Efficiency (@ 230 V AC)	%	91	90
MTTF	h	> 500 · 10 <sup>3</sup>	> 400 · 10 <sup>3</sup>
Start-up delay	s	< 1	< 1
Dielectric strength between input/output	V AC	3000	3000
Dielectric strength between input/PE	V AC	1500	1500
Ambient temperature range***	°C	-20...+70	-20...+70
Protection category		IP 20	IP 20

Approvals (according to type)



- 24 V DC, 60 W output
- Output adjustable between 24-28 V
- ZVS technology
- Suitable for battery charging



- 12 V DC, 50 W output
- Output adjustable between 12-15 V
- ZVS technology
- Suitable for battery charging

Replaceable fuse + spare



- \* (see diagrams P78)
- \*\* peak to peak, 100 Hz component, with 100 V AC input
- \*\*\* (see derating diagrams L78)
- suitable for battery charging (see details page 18)

**Industrial Switch Mode DC Power Supplies: 110 W to 130 W**

**Type 78.1A**  
- Output 24 V DC, 120 W

**Type 78.1B**  
- Output 24 V DC, 110 W, compact size  
- Secure electrical separation (SELV according to EN 60950)

**Type 78.1D**  
- Output 24 V DC, 130 W  
- Double stage active Power Factor Correction

- Fold-Back overload characteristics for Battery charging applications and parallel working for increased load current (78.1D)
- High efficiency (up to 93%)
- Low stand-by power consumption (down to 1 W)
- LLC (78.1B) or forward topology (78.1D)
- Thermal protection: internal with pre-alert alarm via LED and auxiliary contact, and with V<sub>out</sub> safety shutdown - power OFF to reset (78.1D)
- Overload indication: Pre-alert alarm via LED and auxiliary contact indication (78.1D)
- Boost current: Without time limit, with LED and auxiliary contact indication (78.1D)
- Overload protection: Fold-back mode (78.1D)
- Short circuit protection: Hiccup (auto-recovery) mode
- Input fuse: Easily replaceable plus spare
- Overvoltage protection: Varistor
- Compliant with EN 60950-1 and EN 61204-3
- Parallel working for increased load current (with OR diodes)
- Dual Polarity and Series connection permissible
- 35 mm rail (EN 60715) mount

For outline drawing see page 25, 26, 27

**Output specification**

Output current (-20...+50 °C, 230 V AC input)	A	5.0 (@40 °C)	5.0 (@40 °C)	5.4 (@50 °C)
Output current (-20...+50 °C, 120 V AC input)	A	4.5 (@40 °C)	4.5 (@40 °C)	5.4 (@50 °C)
Rated voltage	V	24	24	24
Rated power	W	120	110	130
Output power (-20...+40 °C, 230 V AC input)	W	120	120	130
Peak current capability for 5 ms*	A	10	10	10
Output voltage adjust	V DC	24...28	24...28	24...28
Voltage variation (from no-load to full-load)		< 2%	< 3%	< 1%
Voltage ripple @ full load**	mV	< 500	< 300	< 100
Hold-up time @ full load: with 120 V AC input ms		>25	>20	> 20
with 250 V AC input ms		>110	>90	> 20

**Input specification**

Nominal voltage (U <sub>N</sub> )	V AC (50/60 Hz)	120...240	120...240	110...240
	V DC	—	220	110...240
Operating range	V AC (50/60 Hz)	120...250	100...265	88...265
	V DC	—	140...275 (polarized)	95...275 (non-polarized)
Drop out DC Voltage	V	—	110	80
Max power consumption (@ minimum V AC operating range)	VA	195 (@50 Hz)	268 (@50 Hz)	145 (@50 Hz)
Stand-by power consumption	W	< 1.9	< 1.0	< 3.3
Power factor		0.69	0.5	0.998
Max current consumption	A	1.75 (@120 V AC)	1.75 (@115 V AC)	1.6 (@88 V AC)
Max. inrush current (peak @ 250 V) for 3 ms	A	13	12	12
Replaceable input fuse		—	3.15 A - T	2.5 A - T

**Technical data**

Efficiency (@ 230 V AC)	%	92	93	89
MTTF	h	> 500 · 10 <sup>3</sup>	> 500 · 10 <sup>3</sup>	> 400 · 10 <sup>3</sup>
Start-up delay	s	< 3	< 1	< 1
Dielectric strength between input/output	V AC	2000	2500 (SELV)	2500
Dielectric strength between input/PE	V AC	—	1500	1500
Ambient temperature range***	°C	-20...+60	-20...+70	-20...+70
Protection category		IP 20	IP 20	IP 20

Approvals (according to type)

**NEW 78.1A**



- 24 V DC, 120 W output
- Output adjustable between 24-28 V

Replaceable fuse + spare



**78.1B**



- 24 V DC, 110 W output
- Output adjustable between 24-28 V
- Compact size, low stand-by consumption

Thermal protection with LED indication

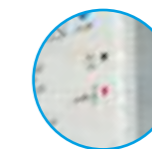

(depending on type)

**78.1D**



- 24 V DC, 130 W output
- Output adjustable between 24-28 V
- Double stage with active PFC (Power Factor Correction)

Auxiliary contact signalling

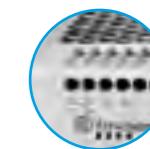

- \* (see diagrams P78)
- \*\* peak to peak, 100 Hz component, with 120 V AC input
- \*\*\* (see derating diagrams L78)
- suitable for battery charging (see details page 18)

Output current (-20...+50 °C, 230 V AC input)	A	5.0 (@40 °C)	5.0 (@40 °C)	5.4 (@50 °C)
Output current (-20...+50 °C, 120 V AC input)	A	4.5 (@40 °C)	4.5 (@40 °C)	5.4 (@50 °C)
Rated voltage	V	24	24	24
Rated power	W	120	110	130
Output power (-20...+40 °C, 230 V AC input)	W	120	120	130
Peak current capability for 5 ms*	A	10	10	10
Output voltage adjust	V DC	24...28	24...28	24...28
Voltage variation (from no-load to full-load)		< 2%	< 3%	< 1%
Voltage ripple @ full load**	mV	< 500	< 300	< 100
Hold-up time @ full load: with 120 V AC input ms		>25	>20	> 20
with 250 V AC input ms		>110	>90	> 20
Nominal voltage (U <sub>N</sub> )	V AC (50/60 Hz)	120...240	120...240	110...240
	V DC	—	220	110...240
Operating range	V AC (50/60 Hz)	120...250	100...265	88...265
	V DC	—	140...275 (polarized)	95...275 (non-polarized)
Drop out DC Voltage	V	—	110	80
Max power consumption (@ minimum V AC operating range)	VA	195 (@50 Hz)	268 (@50 Hz)	145 (@50 Hz)
Stand-by power consumption	W	< 1.9	< 1.0	< 3.3
Power factor		0.69	0.5	0.998
Max current consumption	A	1.75 (@120 V AC)	1.75 (@115 V AC)	1.6 (@88 V AC)
Max. inrush current (peak @ 250 V) for 3 ms	A	13	12	12
Replaceable input fuse		—	3.15 A - T	2.5 A - T
Efficiency (@ 230 V AC)	%	92	93	89
MTTF	h	> 500 · 10 <sup>3</sup>	> 500 · 10 <sup>3</sup>	> 400 · 10 <sup>3</sup>
Start-up delay	s	< 3	< 1	< 1
Dielectric strength between input/output	V AC	2000	2500 (SELV)	2500
Dielectric strength between input/PE	V AC	—	1500	1500
Ambient temperature range***	°C	-20...+60	-20...+70	-20...+70
Protection category		IP 20	IP 20	IP 20



**Industrial Switch Mode DC Power Supply:  
240 W****High efficiency PSU with high peak output current and low stand by power consumption****Type 78.2A**

- Output 24 V DC, 240 W
- High efficiency (up to 94%)
- Low stand-by power consumption
- LLC topology
- Thermal protection internal, power OFF to reset
- Boost current: Without time limit
- Short circuit protection: Hiccup (auto-recovery) mode
- Overvoltage protection: Varistor
- Compliant with EN 61204-3
- Parallel working for increased load current (with OR diodes)
- Dual Polarity and Series connection permissible
- 35 mm rail (EN 60715) mount

Screw terminal



For outline drawing see page 27

**Output specification**

Output current (-20...+40 °C, 230 V AC input)	A	10
Output current (-20...+40 °C, 120 V AC input)	A	9
Rated voltage	V	24
Rated power	W	240
Output power (-20...+40 °C, 230 V AC input)	W	240
Peak current capability for 5 ms*	A	25
Output voltage adjust	V DC	24...28
Voltage variation (from no-load to full-load)		< 3%
Voltage ripple @ full load**	mV	< 300
Hold-up time @ full load: with 100 V AC input ms		> 30
with 250 V AC input ms		> 50

**Input specification**

Nominal voltage (U <sub>N</sub> )	V AC (50/60 Hz)	120 or 230
Operating range	V AC (50/60 Hz)	95...130 or 185...250
Drop out DC Voltage	V	—
Max power consumption	VA	361 (@ 50 Hz)
(@ minimum V AC operating range)	W	265 (@ 50 Hz)
Stand-by power consumption	W	≤ 3 @ 120 V; ≤ 2.6 W @ 230 V
Power factor		0.73
Max current consumption	A	3.5 (@ 100 V AC)
Max. inrush current (peak @ 265 V) for 3 ms	A	14
Replaceable input fuse		—

**Technical data**

Efficiency (@ 230 V AC)	%	94
MTTF	h	> 400 · 10 <sup>3</sup>
Start-up delay	s	< 1
Dielectric strength between input/output	V AC	2000
Dielectric strength between input/PE	V AC	—
Ambient temperature range***	°C	-20...+60
Protection category		IP 20

**Approvals** (according to type)**NEW 78.2A**

- 24 V DC, 240 W output
- Output adjustable between 24-28 V

\* (see diagrams P78)

\*\* peak to peak, 100 Hz component, with 100 V AC input

\*\*\* (see derating diagrams L78)

suitable for battery charging

**Industrial Switch Mode DC Power Supply:  
240 W****Overload characteristics support parallel working for increased load current****Type 78.2E**

- Output 24 V DC, 240 W
- Double stage active Power Factor Correction
- High efficiency (up to 93%)
- Low stand-by power consumption
- Forward topology
- Thermal protection: internal with pre-alert alarm via LED and auxiliary contact, and with V<sub>out</sub> safety shutdown - power OFF to reset
- Overload indication: Pre-alert alarm via LED and auxiliary contact indication
- Boost current: Without time limit, with LED and auxiliary contact indication
- Overload up to 20 A
- Short circuit protection: Hiccup (auto-recovery) mode
- Input fuse: Easily replaceable plus spare
- Overvoltage protection: Varistor
- Compliant with EN 60950-1 and 61204-3
- Parallel working for increased load current (with OR diodes)
- Dual Polarity and Series connection permissible
- 35 mm rail (EN 60715) mount

Screw terminal



For outline drawing see page 26

**Output specification**

Output current (-20...+40 °C, 230 V AC input)	A	10.8
Rated current I <sub>N</sub>	A	10
(50 °C, full input operating range)		
Rated voltage	V	24
Rated power	W	240
Output power (-20...+40 °C, 230 V AC input)	W	250
Peak current capability for 5 ms*	A	25
Output voltage adjust	V DC	24...28
Voltage variation (from no-load to full-load)		< 1%
Voltage ripple @ full load**	mV	< 100
Hold-up time @ full load: with 110 V AC input ms		> 20
with 260 V AC input ms		> 20

**Input specification**

Nominal voltage (U <sub>N</sub> )	V AC (50/60 Hz)	110...240
	V DC	110...240
Operating range	V AC (50/60 Hz)	88...265
	V DC	90...275 (non-polarised)
Drop out DC Voltage	V	80
Max power consumption	VA	275 (@ 50 Hz)
(@ minimum V AC operating range)	W	274 (@ 50 Hz)
Stand-by power consumption (@ 88 V)	W	≤ 2.8
Power factor		0.995
Max current consumption	A	3.0 (@ 88 V AC)
Max. inrush current (peak @ 265 V) for 3 ms	A	12
Replaceable input fuse		3.15 A - T

**Technical data**

Efficiency (@ 230 V AC)	%	93
MTTF	h	> 400 · 10 <sup>3</sup>
Start-up delay	s	< 1
Dielectric strength between input/output	V AC	2500
Dielectric strength between input/PE	V AC	1500
Ambient temperature range***	°C	-20...+70
Protection category		IP 20

**Approvals** (according to type)**78.2E**

- 24 V DC, 240 W output
- Output adjustable between 24-28 V
- Double stage with active PFC (Power Factor Correction)

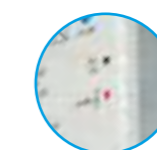
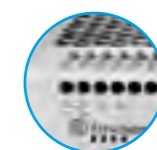
Replaceable fuse  
+ spareThermal protection  
with LED indicationAuxiliary contact  
signalling

\* (see diagrams P78)

\*\* peak to peak, 100 Hz component, with 110 V AC input

\*\*\* (see derating diagrams L78)

**KNX power supply with 30 V DC output - 640 mA**

- Output 30 V DC 640 mA, KNX Bus
- Diagnostic LEDs
- 72 mm wide (4 modules)
- 35 mm rail (EN 60715) mount
- Suitable for ETS 4 (or latest versions)

78.2K

Screw terminal

**NEW 78.2K.1.230.3000**

- Thermal protection, overload protection and short-circuit protection
  - No minimum distance required between adjacent power supplies.
- It is possible to use two or more power supplies within a panel to provide for redundancy

F For outline drawing see page 28

**Output specification**

Output current	mA	640
Output voltage	V	30

**Input specification**

Nominal voltage (U <sub>N</sub> )	V AC	230...240
Operating range	V AC	185 - 260
Stand-by power consumption	W	1.45
Power factor		0.62
Max current consumption	A	0.25

**Technical data**

Dielectric strength between input/output	V AC	3000
Ambient temperature range	°C	-5/+45
Protection category		IP 20

**Approvals** (according to type)**Ordering information**

Example: 78 series switch mode power supply, 36 W - 24 V DC output, supply voltage 110...240 V AC, replaceable fuse.

7 8 . 3 6 . 1 . 2 3 0 . 2 4 0 1

A B C D

**Series****Power**

- 12 = 12 W output
- 25 = 25 W output
- 36 = 36 W output
- 50/51 = 50 W output
- 60/61 = 60 W output
- 1A = 120 W output
- 2A = 240 W output
- 1B = 110 W output
- 1D = 130 W output
- 2E = 240 W output
- 2K = KNX 640 mA

**Voltage conversion**

- 1 = AC/DC input, DC output
- 1 = AC input, DC output (78.1A, 78.2A, 78.2K)

**Input voltage**

- 230 = 110...240 V AC / 220V DC
- 230 = 110...240 V AC/DC
- 230 = 120...240 V AC / 220V DC
- 230 = 230...240 V AC (78.2K)
- 230 = 120 or 230 V AC adjustable (78.2A)

**D:**

- 0 = Standard
- 1 = Replaceable fuse
- 2 = Embedded fuse + output voltage regulator
- 3 = Replaceable fuse + output voltage regulator
- 4 = Fuse + regulator + positive logic contact
- 5 = Fuse + regulator + pre-alarm contact

**C:**

- 0 = Standard
- 1 = Double stage, with PFC (Power Factor Correction)

**AB:**

- 12 = 12 V output
- 24 = 24 V output
- 30 = 30 V output KNX

**Codes**

- 78.12.1.230.1200
- 78.12.1.230.2400
- 78.25.1.230.1200
- 78.25.1.230.2400
- 78.36.1.230.2401
- 78.50.1.230.1203
- 78.51.1.230.1203
- 78.60.1.230.2403
- 78.61.1.230.2403
- 78.1A.1.230.2402
- 78.2A.1.230.2402
- 78.1B.1.230.2403
- 78.1D.1.230.2414
- 78.1D.1.230.2415
- 78.2E.1.230.2414
- 78.2E.1.230.2415
- 78.2K.1.230.3000

## Technical data

EMC specifications (according to EN 61204-3)		Reference standard	78.12, 78.25, 78.36	78.60, 78.50	78.61, 78.51	78.1A	78.1B	78.1D	78.2A	78.2E
Electrostatic discharge	contact discharge	EN 61000-4-2	4 kV	4 kV	4 kV	4 kV	4 kV	4 kV	4 kV	4 kV
	air discharge	EN 61000-4-2	8 kV	8 kV	8 kV	8 kV	8 kV	8 kV	8 kV	8 kV
Radiated electromagnetic field	80...1000 MHz	EN 61000-4-3	6 V/m	10 V/m	10 V/m	10 V/m	10 V/m	10 V/m	10 V/m	10 V/m
	1...2.8 GHz	EN 61000-4-3	3 V/m	3 V/m	3 V/m	3 V/m	3 V/m	3 V/m	10 V/m	10 V/m
Fast transients (burst 5/50 ns, 5 and 100 kHz)	on supply terminals	EN 61000-4-4	2 kV	3 kV	3 kV	2 kV	2 kV	3 kV	3 kV	3 kV
Voltage pulses on supply terminals (surge 1.2/50 µs)	common mode	EN 61000-4-5	2 kV	2 kV	2 kV	2 kV	2 kV	3 kV	2.5 kV	2.5 kV
	differential mode	EN 61000-4-5	2 kV (78.12), 4 kV* (78.36)	4 kV*	4 kV*	4 kV**	4 kV**	4 kV**	4 kV	4 kV**
Radio-frequency common mode voltage (0.15...230 MHz)	on supply terminals	EN 61000-4-6	6 V	10 V	10 V	10 V	10 V	10 V	10 V	10 V
Short interruptions		EN 61000-4-11	5 cycles	6 cycles	6 cycles	5 cycles	5 cycles	6 cycles	5 cycles	5 cycles
Radio-frequency conducted emissions	0.15...30 MHz	EN 55022	class B	class A	class B	class A	class B	class B	class A	class B
Radiated emissions	30...1000 MHz	EN 55022	class B	class A	class B	class A	class A	class A	class A	class A
<b>Terminals</b>			<b>Max</b>		<b>Min...Max</b>					
Wire size (Solid cable, stranded cable)		mm <sup>2</sup>	1 x 4 / 2 x 2.5		1 x 0.5...1 x 4					
		AWG	1 x 12 / 2 x 14		1 x 20...1 x 12					
Wire size (Solid cable, stranded cable for 78.1A and 78.2A)		mm <sup>2</sup>	1 x 2.5		1 x 0.5...2.5					
		AWG	1 x 14		1 x 20...14					
Screw torque		Nm	0.8		0.5					
Wire strip length		mm	8 / 8 (for 78.1A and 78.2A)		8 / 8 (for 78.1A and 78.2A)					
<b>Other data</b>										
Power lost to the environment with rated output current		W	2 (78.12), 2.3 (78.25), 5 (78.36, 78.50/51), 5.4 (78.60/61)							
		W	10 (78.1A), 9 (78.1B), 13.2 (78.1D), 15.3 (78.2A), 16.8 (78.2E)							

\* input fuse may blow for surges higher than 1.5 kV

\*\* input fuse may blow for surges higher than 2 kV

## Technical data for 78.2K

EMC specifications (according to EN 61204-3)		Reference standard	78.2K
Electrostatic discharge	contact discharge	EN 61000-4-2	4 kV
	air discharge	EN 61000-4-2	8 kV
Radiated electromagnetic field	80...1000 MHz	EN 61000-4-3	10 V/m
	1...2.8 GHz	EN 61000-4-3	3 V/m
Fast transients (burst 5/50 ns, 5 and 100 kHz)	HBES terminals	EN 61000-4-4	1 kV
	on supply terminals	EN 61000-4-4	2 kV
Voltage pulses on supply terminals (surge 1.2/50 µs)	DM supply terminals	EN 61000-4-5	1 kV
	CM supply terminals	EN 61000-4-5	2 kV
	HBES terminals	EN 61000-4-5	2 kV
Radio-frequency common mode voltage (0.15...230 MHz)	HBES terminals	EN 61000-4-6	10 V
	on supply terminals	EN 61000-4-6	10 V
Short interruptions	criterion A	EN 61000-4-11	10 cycles
Radio-frequency conducted emissions	0.15...30 MHz	EN 55022	class B
Radiated emissions	30...1000 MHz	EN 55022	class B
<b>Terminals</b>			<b>Max</b>
Wire size (Solid cable, stranded cable)		mm <sup>2</sup>	1 x 4 / 2 x 2.5
		AWG	1 x 12 / 2 x 14
Screw torque		Nm	0.8
Wire strip length		mm	9
<b>Other data</b>			
Power lost to the environment with rated output current		W	4.8

DM: differential mode

CM: common mode

## Output specification

L78-1 Output current v ambient temperature (78.12)

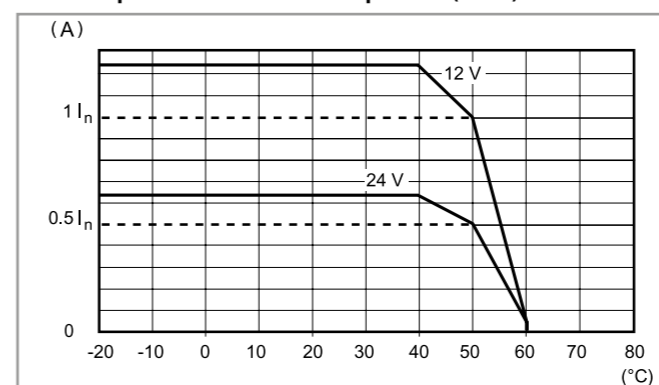

P78-1 Output peak current v time (78.12)

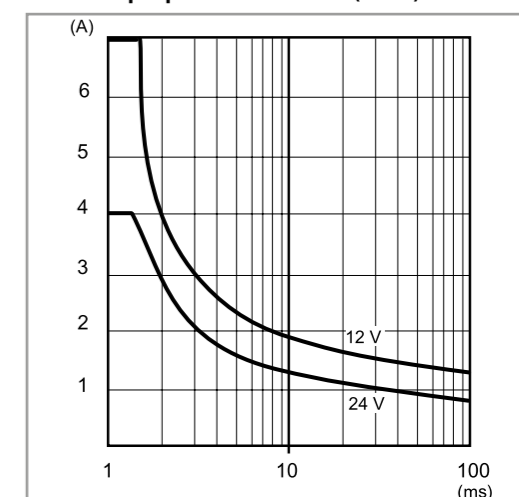

L78-2 Output current v ambient temperature (78.25)

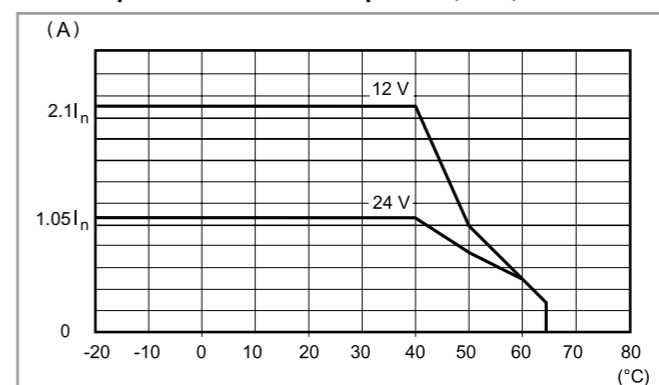

P78-2 Output peak current v time (78.25)

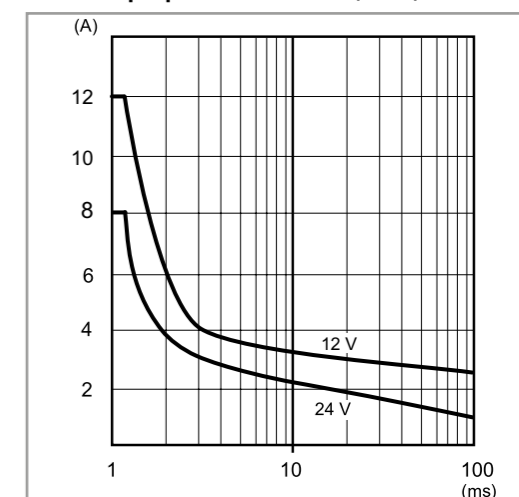

L78-3 Output current v ambient temperature (78.36)

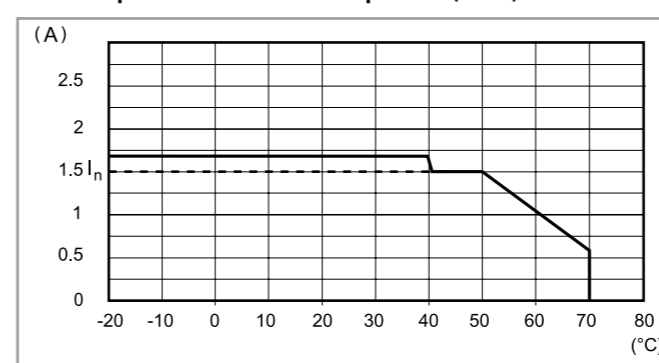

P78-3 Output peak current v time (78.36)

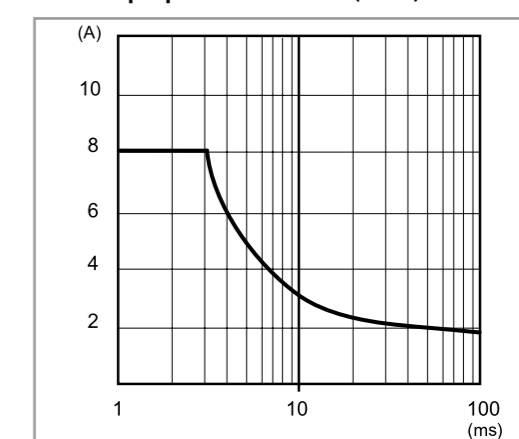

## Output specification

L78-4 Output current v ambient temperature (78.60)

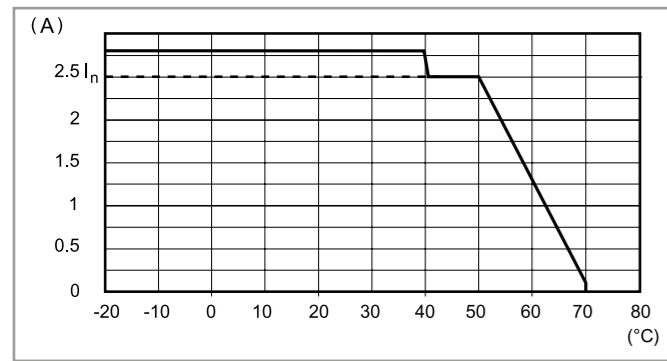

P78-4 Output peak current v time (78.60)

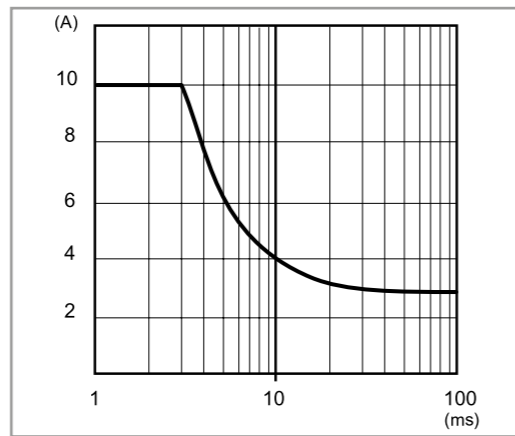

L78-5 Output current v ambient temperature (78.50/51)

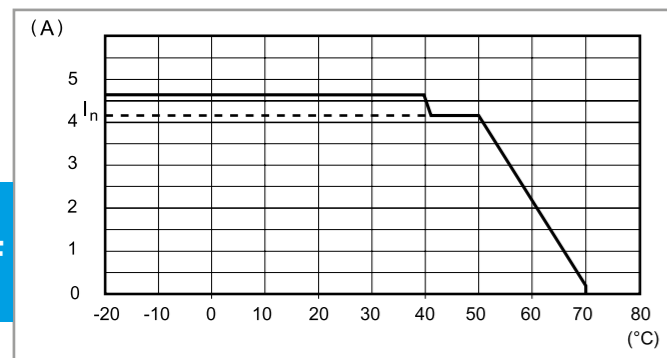

P78-5 Output peak current v time (78.50/51)

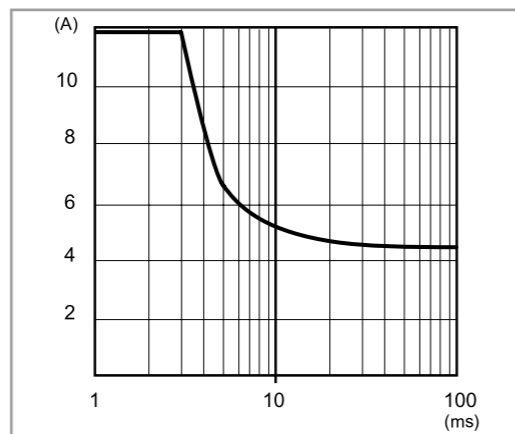

L78-6 Output current v ambient temperature (78.61)

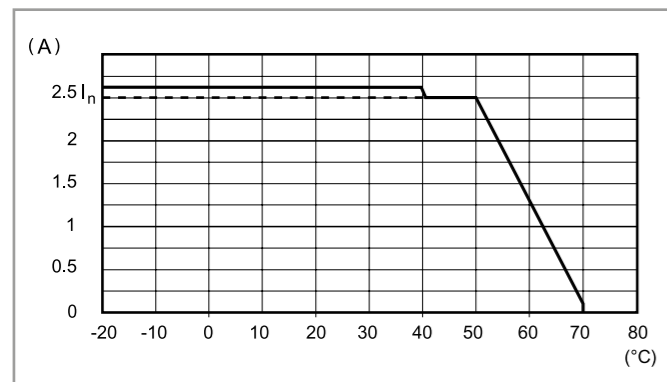

P78-6 Output peak current v time (78.61)

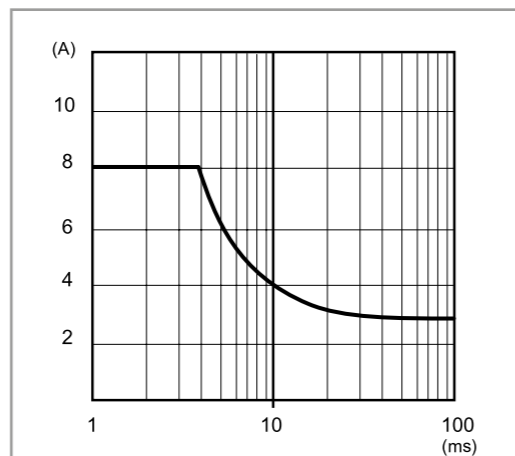

## Output specification

L78-7 Output current v ambient temperature (78.1A)

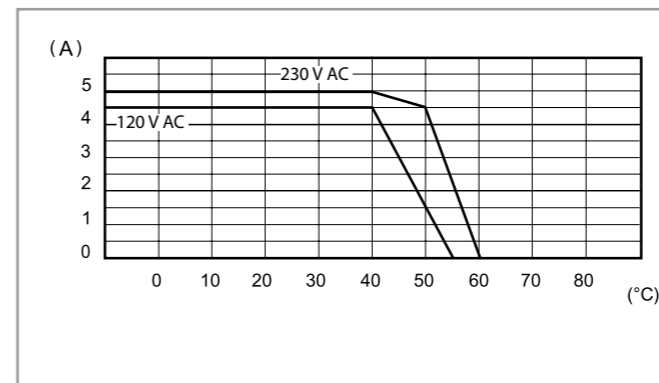

P78-7 Output peak current v time (78.1A)

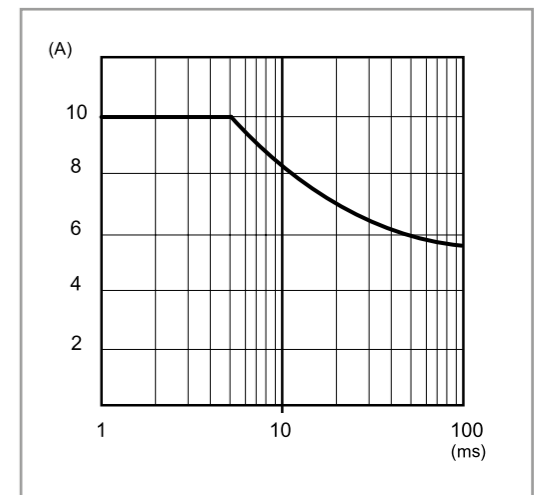

L78-8 Output current v ambient temperature (78.1B)

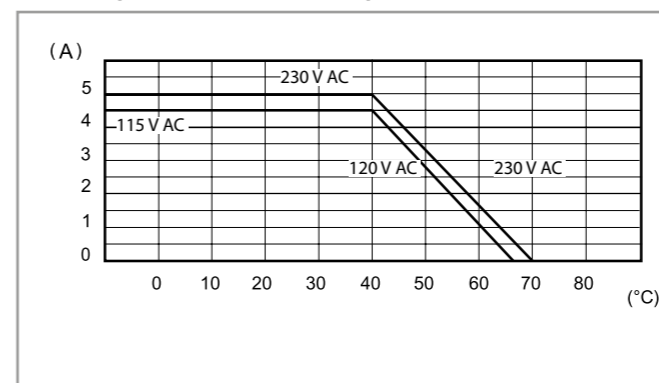

P78-8 Output peak current v time (78.1B)

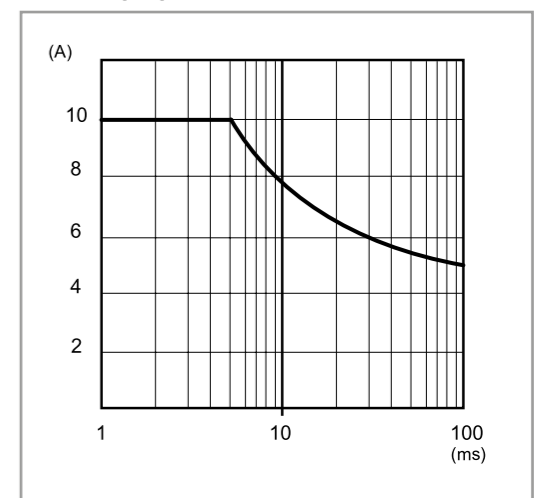

L78-9 Output current v ambient temperature (78.1D)

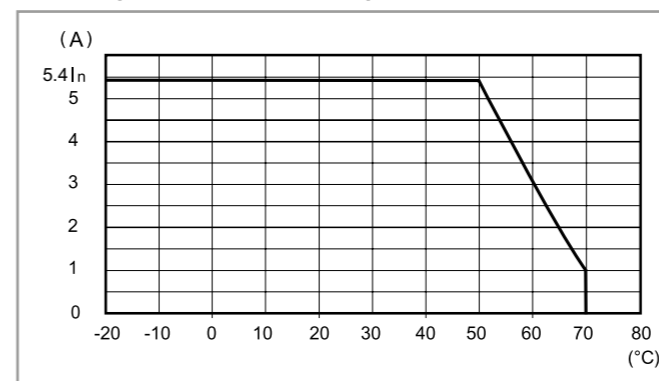

P78-9 Output peak current v time (78.1D)

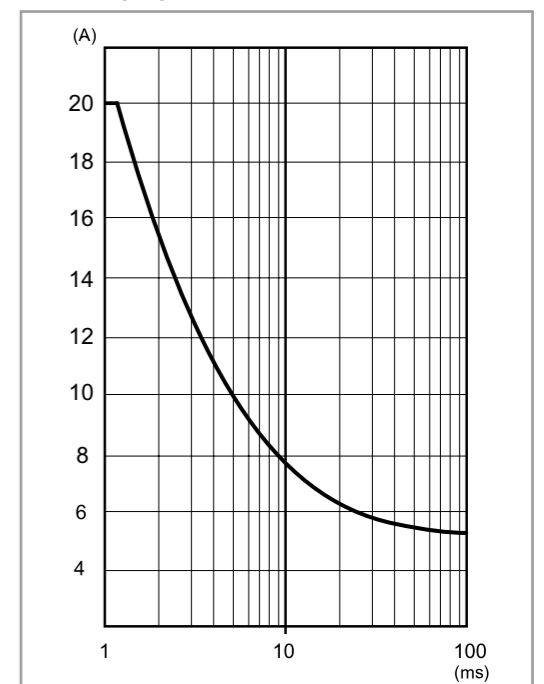



## Output specification

L78-10 Output current v ambient temperature (78.2A)

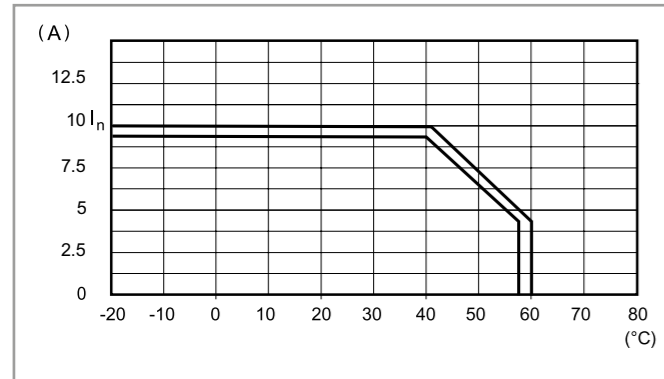

P78-10 Output peak current v time (78.2A)

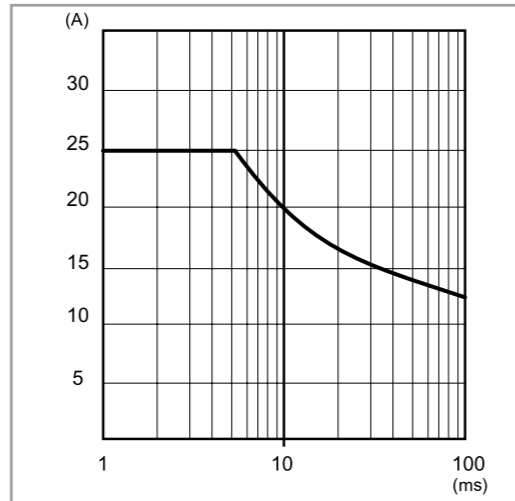

F L78-11 Output current v ambient temperature (78.2E)

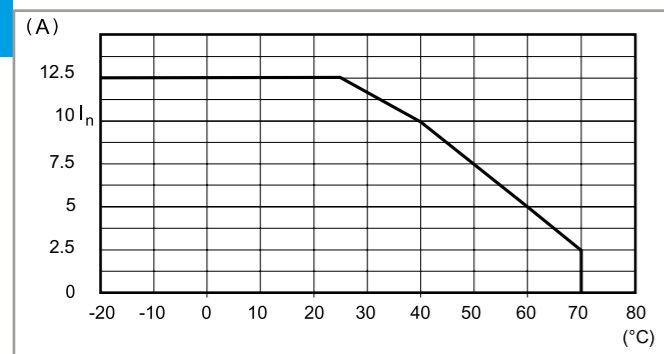

P78-11 Output peak current v time (78.2E)

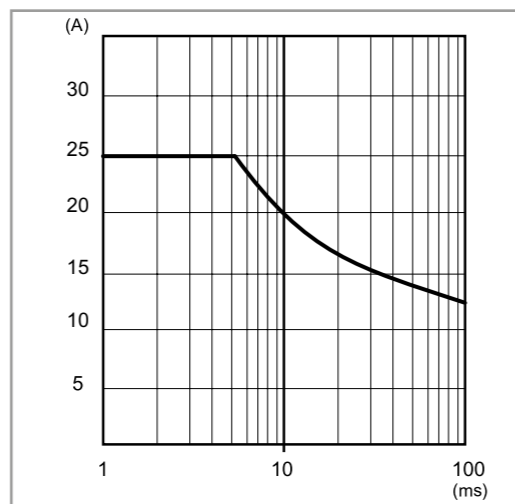

## Output specification

FB78-5 Output voltage v output current (78.2E)

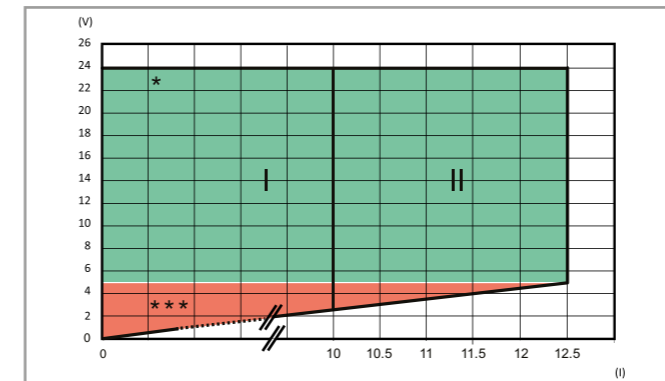

I: Output characteristic for temperature up to 50 °C  
 II: Output characteristic for temperature up to 25 °C  
 \* / \*\*\*: See LED table below

FB78-6 Output voltage v output current (78.2K)

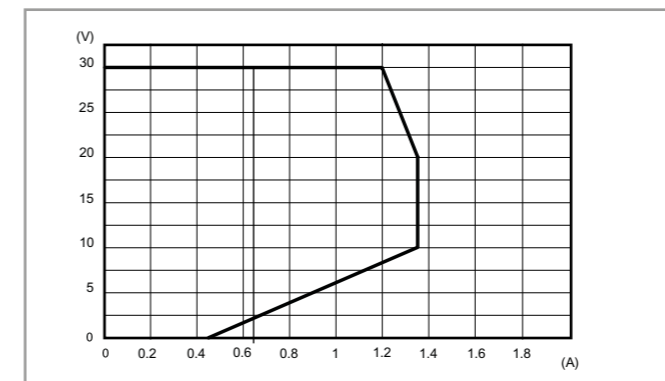

Overload diagram, KNX approved

## Hiccup mode

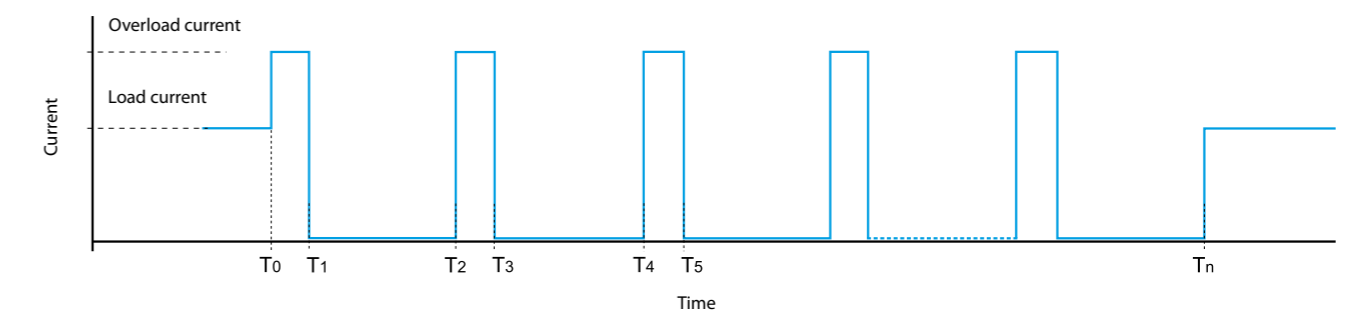

Under normal conditions, the 78 Series Power Supply supplies the current required by the load. However, under abnormal conditions such as a short circuit or heavy overload ( $T_0$ ) the output voltage will be rapidly reduced to zero - followed by the current ( $T_1$ ). After approximately 2 seconds ( $T_1$  to  $T_2$ ), the power supply checks for the persistence of the anomaly over the time period  $T_2$  to  $T_3$  (30 to 100ms - dependent on the type of anomaly). If the anomaly persists, as shown above, the current is again reset to 0 A for a further 2 s ( $T_3$  to  $T_4$ ). This "hiccup" process is repeated until the anomaly is removed ( $T_n$ ), whereon the power supply then returns to normal working.

78.1B is able to handle this anomaly for 15 s. After this time it enters in protection mode, and a manual reset is necessary by removing and re-applying the supply voltage

### Fold-back technology and battery charging

**Fold-back technology** allows load current to be maintained under conditions of heavy overload. In case of heavy overload, the fold-back circuit will provide the output current and the output voltage, in accordance with the relevant "FB" diagram. In practice, when overcurrent is drawn by the load, the fold-back circuit reduces the output voltage supplying the current up to the maximal value, then it starts to work in hiccup mode. Also in case of short circuit, the power supply will work in hiccup mode. Both these conditions end when the anomaly is removed, and the power supply returns to normal working.

The fold-back mode allows the use of the power supply as a **battery charger**, in particular 78.51/61 for charging lead acid batteries (both standard and gel types) rated 7...24 Ah and 78.1D for charging lead batteries rated 17...38 Ah. In any case, it is necessary to verify that the charging characteristics of the batteries are compliant with the output characteristics of the power supply.

It is suggested to insert a diode in series between the + output and the + input of the battery (if not already installed in the battery unit).

#### Back-up connection for mains interruption

When the mains is ON, the power supply is able to charge the battery and supply the load at the same time (the power supply must be rated minimum 110 % of the load). When the mains is OFF, the battery starts to supply the load.

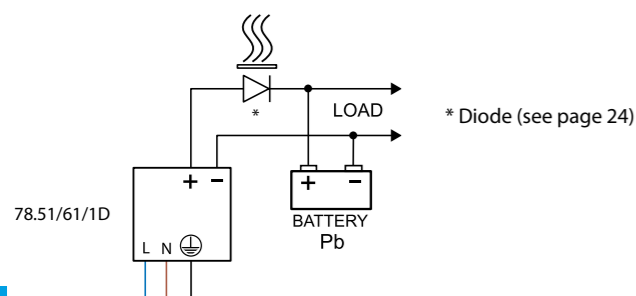

FB78-1 Output voltage v output current (78.51)

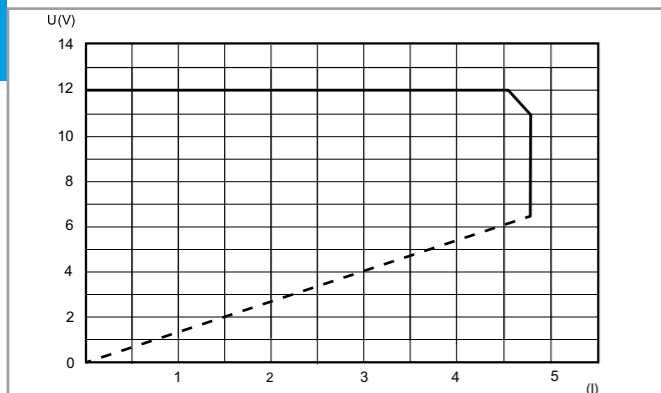

FB78-2 Output voltage v output current (78.61)

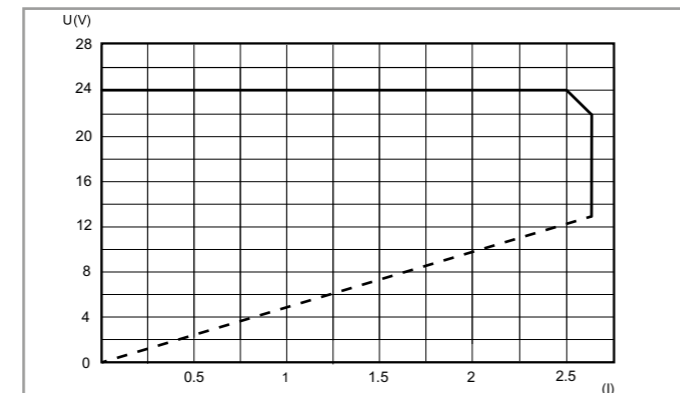

FB78-3 Output voltage v output current (78.1D)

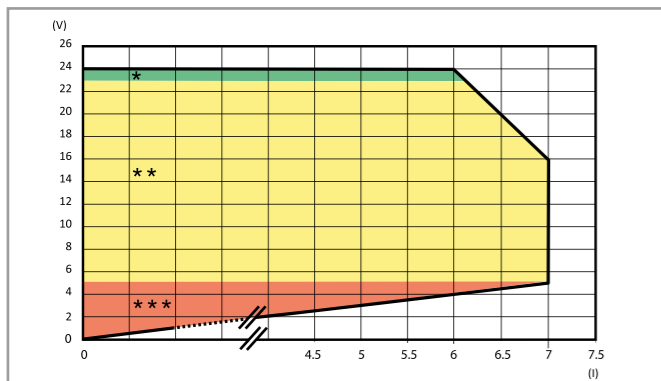

Fold-back characteristic for ambient temperature up to 50 °C

\* / \*\* / \*\*\*: See LED table below

### 78.1D, 78.2E LED table

#### Feedback contact switching mode: Type 78.xx.x.xxx.24x4 ("positive logic")

The NO contact closes when power is applied to the unit and remains closed unless there is a serious fault preventing the power supply unit from delivering output current. (Such as a broken fuse, power supply failure, short-circuit or thermal protection.)

This version is suitable, for example, for signalling to a remote PLC all those alarms representing a service interruption of the power supply output.

Type	Area	State	LED	Contact 13-14
78.1D.1.230.2414 78.2E.1.230.2414	*	OK	DC OK ALARM  OFF	
	**	Overload (78.1D only)	DC OK ALARM  OFF	
	***	Short circuit	DC OK ALARM  OFF	
		Thermal limit	DC OK ALARM	
		Thermal protection#	DC OK ALARM  OFF	

#Remove the supply voltage, following the intervention of the thermal protection, in order to reset the power supply.

### 78.1D, 78.2E LED table

#### Feedback contact switching mode: Type 78.xx.x.xxx.24x5 ("pre-alarm")

The NO contact closes when an anomaly happens (Overload, short circuit, thermal limit, thermal protection).

This version is suitable, for example, for activating visual or audible alarms, or to activate a cooling fan.

Type	Area	State	LED	Contact 13-14
78.1D.1.230.2415 78.2E.1.230.2415	*	OK	DC OK ALARM  OFF	
	**	Overload (78.1D only)	DC OK ALARM  OFF	
	***	Short circuit	DC OK ALARM  OFF	
		Thermal limit	DC OK ALARM	
		Thermal protection#	DC OK ALARM  OFF	

#Remove the supply voltage, following the intervention of the thermal protection, in order to reset the power supply.

### 78.12, 78.25, 78.36, 78.50, 78.60, 78.51, 78.61, 78.1A, 78.2A, 78.1B LED table

Type	State	LED
78.12.1.230.xx00 78.25.1.230.1200 78.25.1.230.2400 78.36.1.230.2401 78.50.1.230.1203 78.60.1.230.2403 78.51.1.230.1203 78.61.1.230.2403 78.1A.1.230.2402	OK	
	Short circuit	
	Thermal limit	OFF
78.2A.1.230.2402 78.1B.1.230.2403	OK	
	Short circuit	OFF
	Thermal limit	OFF

LED table

Type	Area	State	LED	OUTPUT
78.2K.1.230.3000	CHECK START UP	$V_{out} OK$	 • OFF • OFF	ON
		$V_{out} LOW < 29V$	 • OFF • OFF	OFF
		$V_{out} HIGH > 33V$	 • OFF • OFF	OFF
	NORMAL FUNCTION	$V_{out} OK$ $I_{out} > 0.9A$	 • OFF 	ON
		$V_{out} < 29V$ $I_{out} > 0.9A$	• OFF • OFF 	ON
	 Alarm condition: $T_{amb} > 45^{\circ}C @ I_{nom}$ .	Pre-alarm: up to 60s	• OFF 	ON
		Latched alarm	• OFF • OFF 	OFF

Wiring diagrams for 78.12, 78.25, 78.36, 78.50, 78.51, 78.60 & 78.61

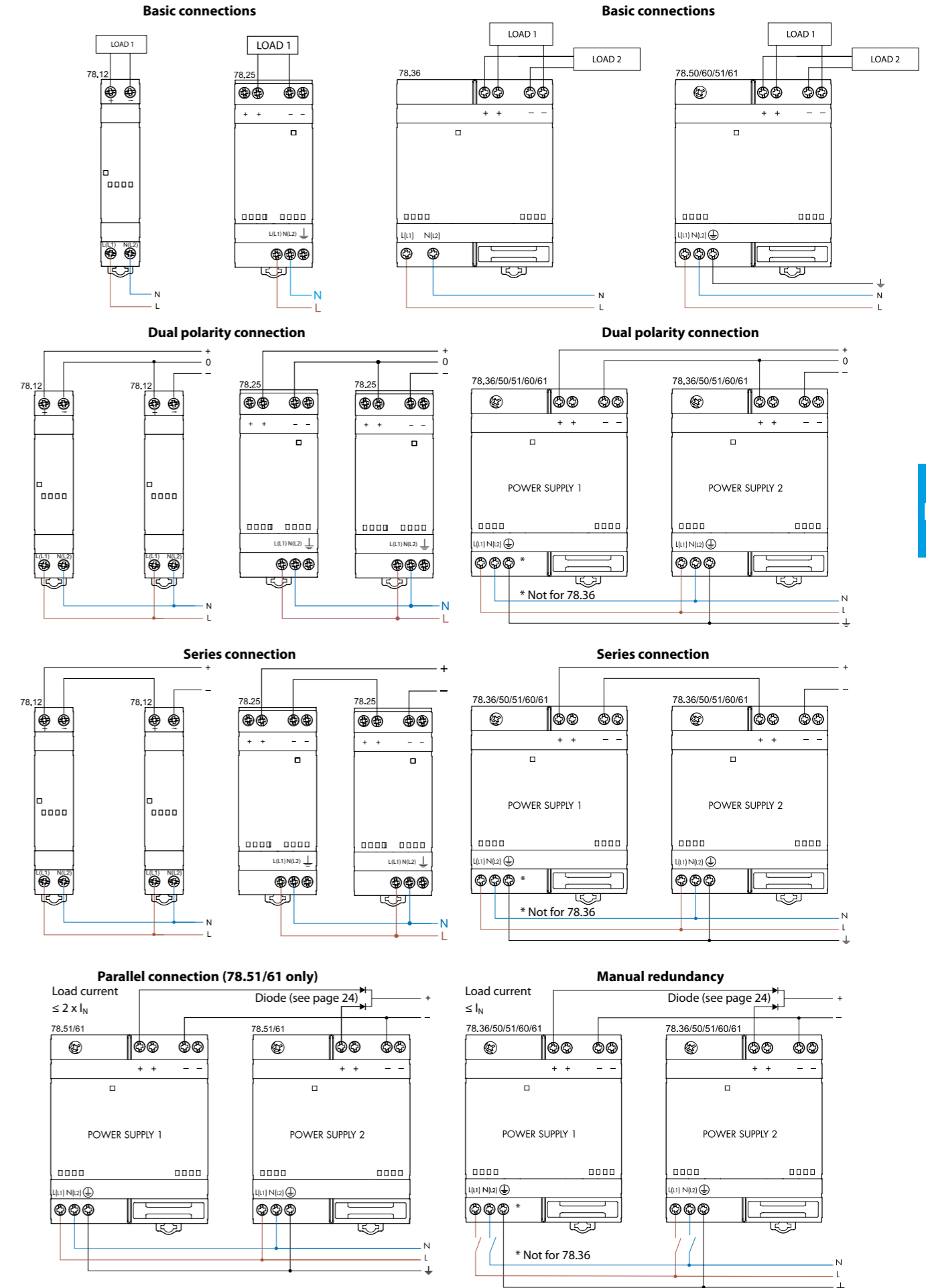

F

F

Wiring diagrams for 78.1B & 78.1D

Basic connections

78.1B - Power supply connection

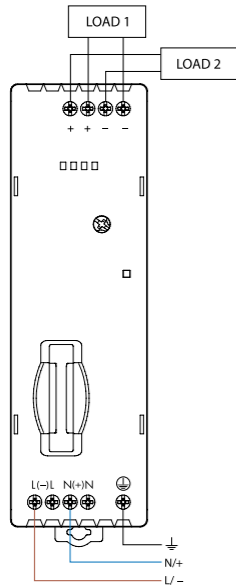

78.1D - Power supply connection

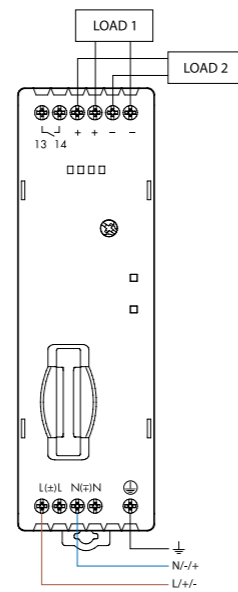

Dual polarity connection

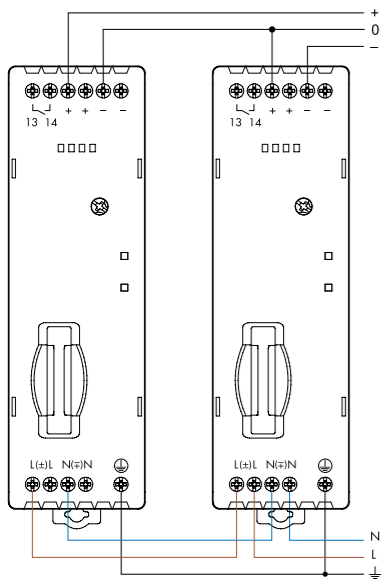

Parallel connection

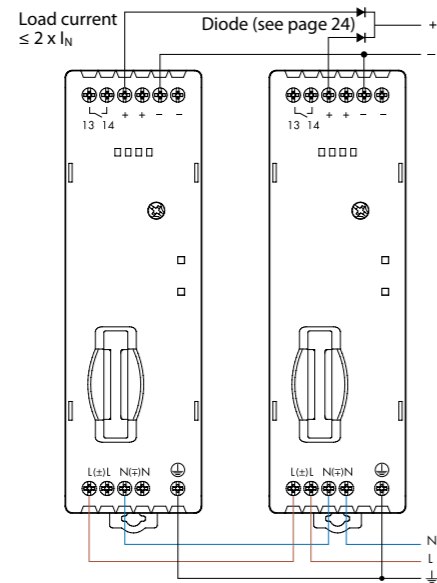

Series connection

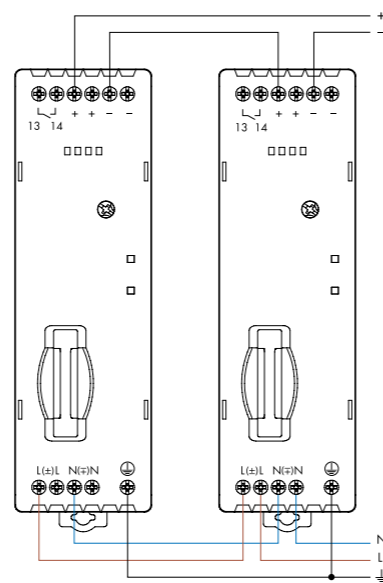

Wiring diagrams for 78.2E

Basic connections

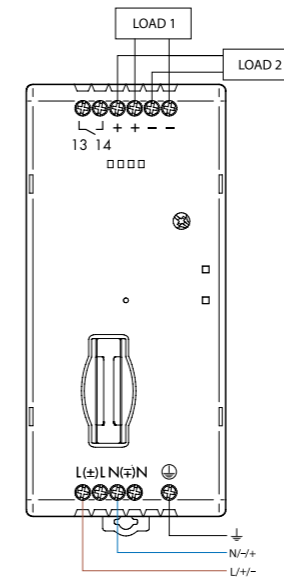

Dual polarity connection

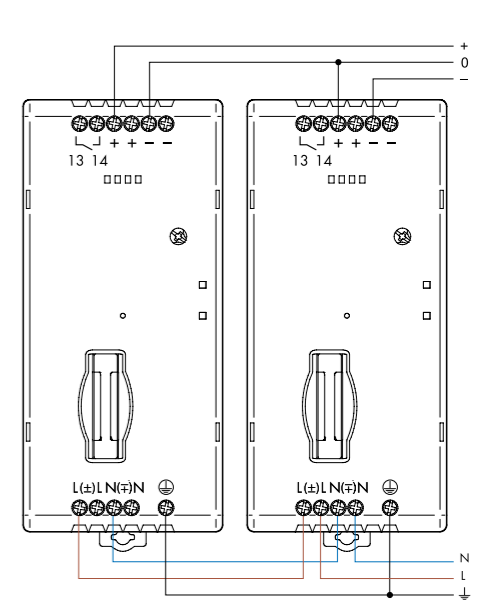

Parallel connection

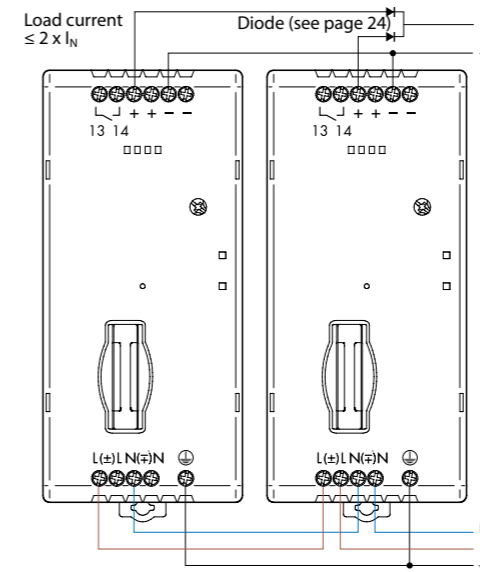

Series connection

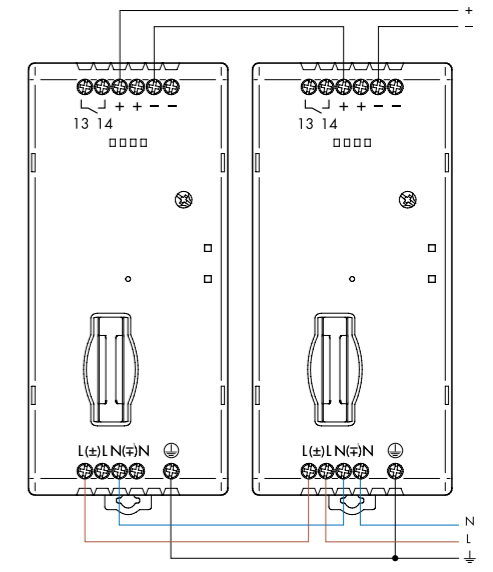

Wiring diagram for 78.1A

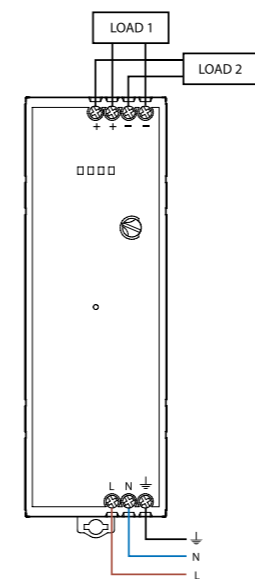

Wiring diagram for 78.2A

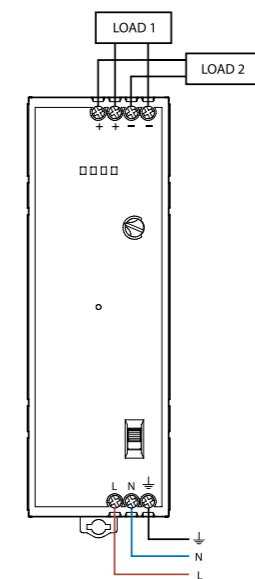

Wiring diagram for 78.2K

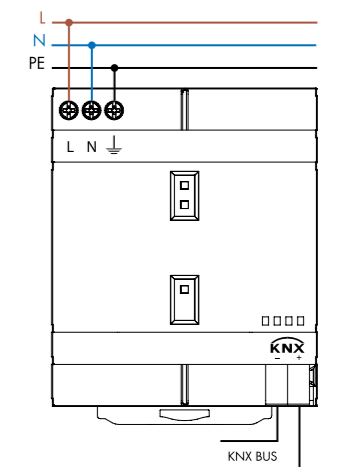

F

F

Diode(s)

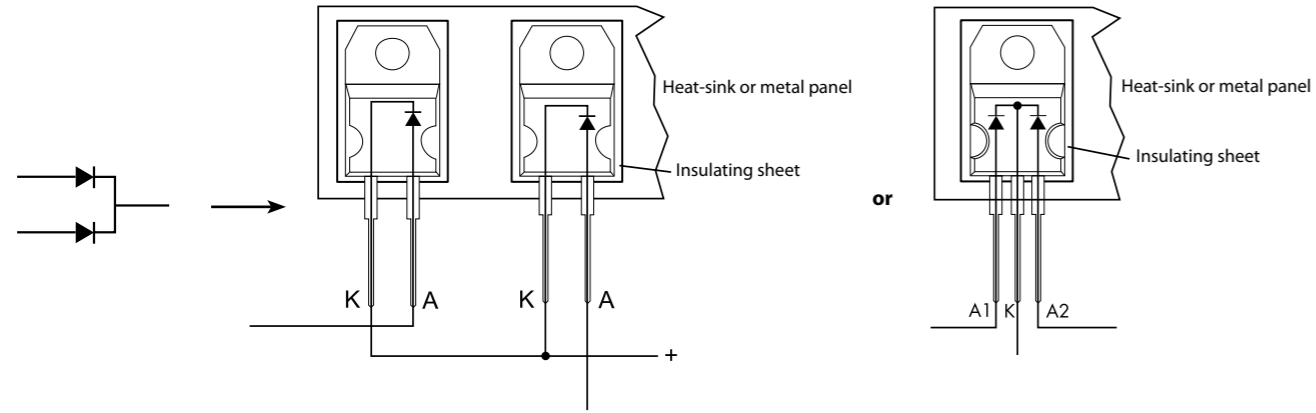

Diode for type 78.25, 78.36, 78.50, 78.60, 78.51, 78.61

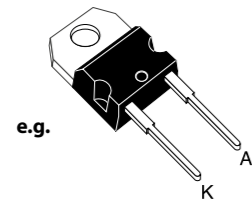

e.g.  
**TO-220AC**  
**STPS1545D**

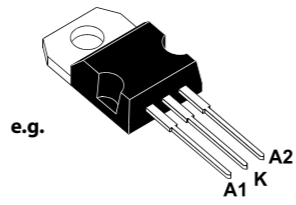

e.g.  
**TO-220AB**  
**STPS30L40CT**

Diode for type 78.1B, 78.1D, 78.2E

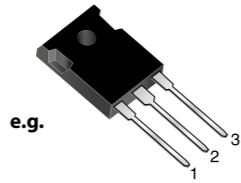

e.g.

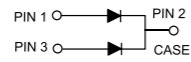

**TO-247AD**  
**MBR 4060PT**

Outline drawings

Type 78.12  
Screw terminal

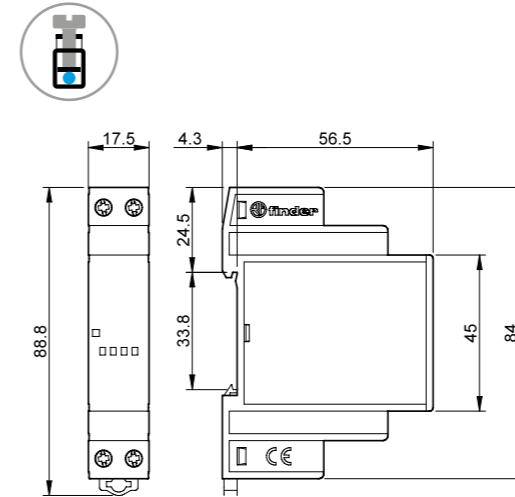

Type 78.25  
Screw terminal

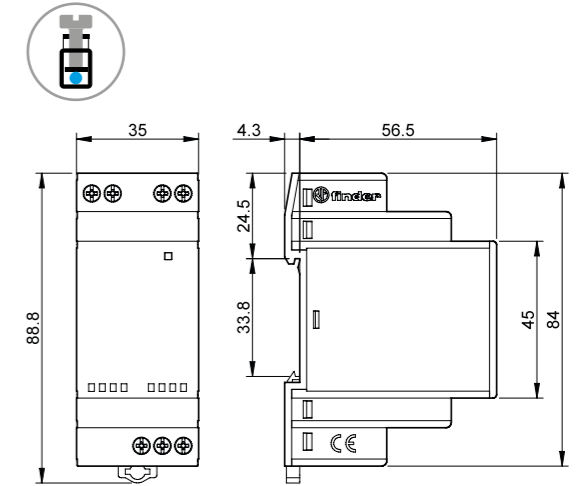

Type 78.36  
Screw terminal

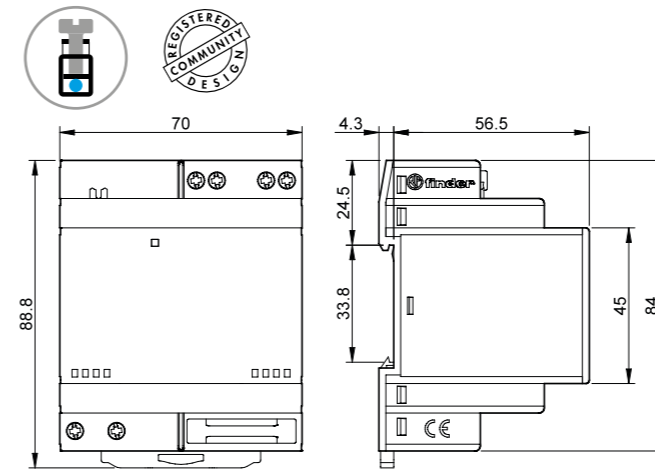

Types 78.50 / 78.60  
Screw terminal

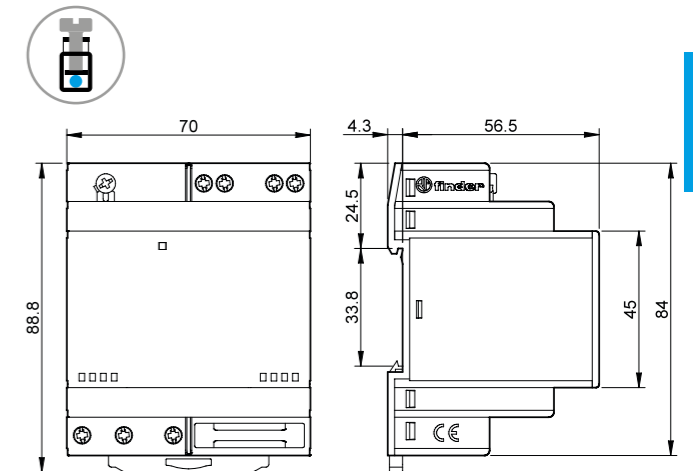

Types 78.51 / 78.61  
Screw terminal

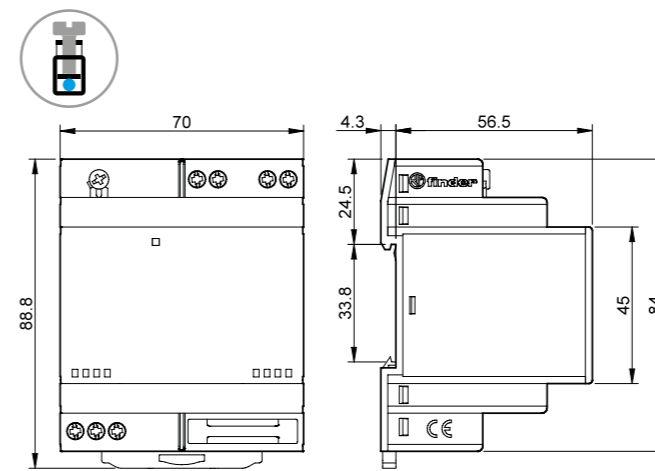

Type 78.1B  
Screw terminal

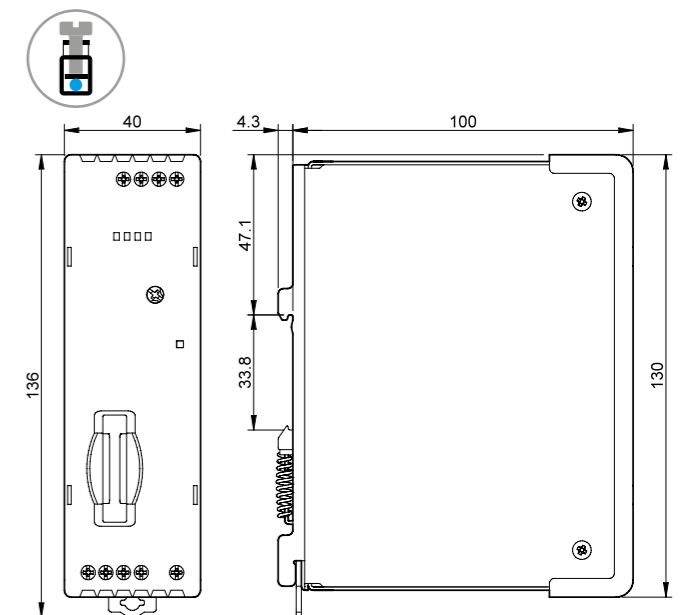

F

F

## Outline drawings

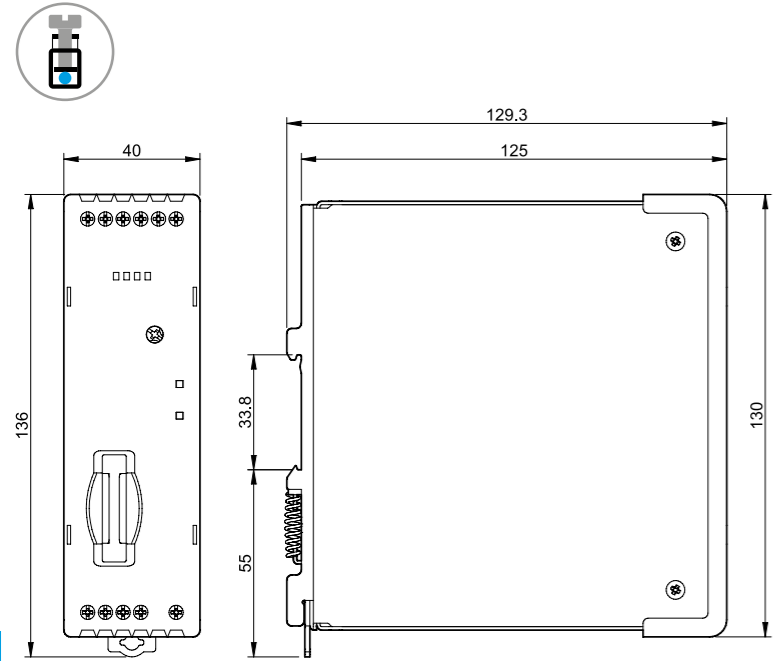
Type 78.1D  
Screw terminal

F

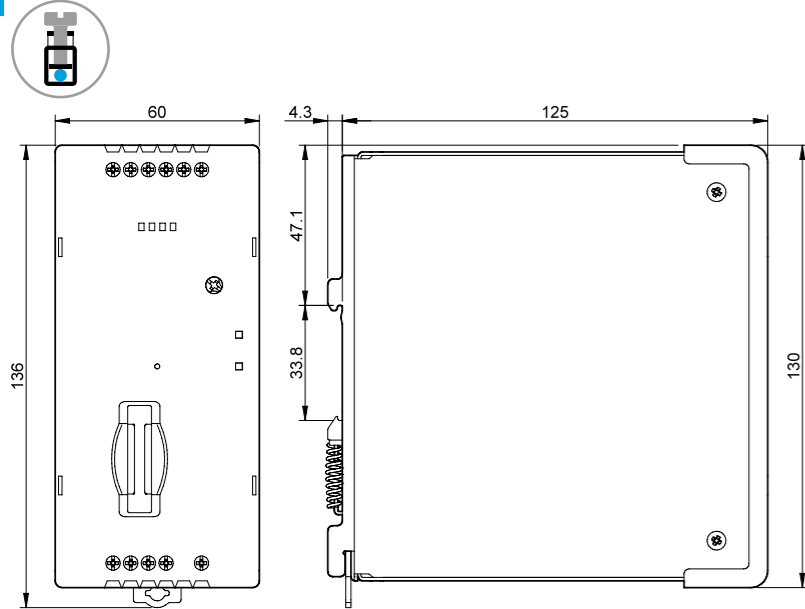
Type 78.2E  
Screw terminal

## Outline drawings

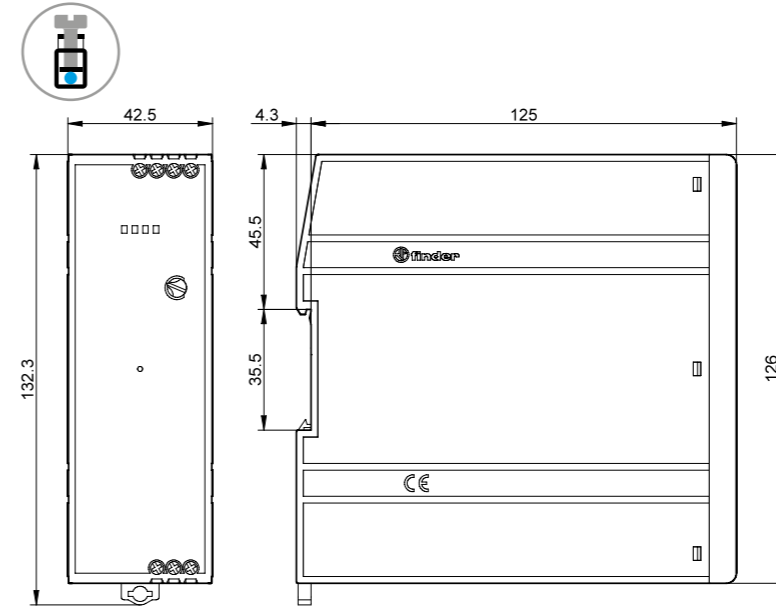
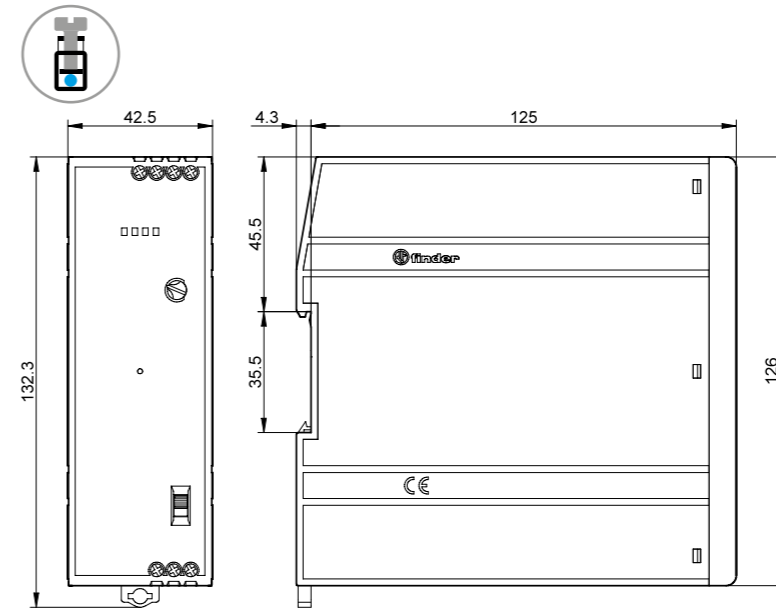
Type 78.1A  
Screw terminalType 78.2A  
Screw terminal

F

## Outline drawings

Type 78.2K  
Screw terminal

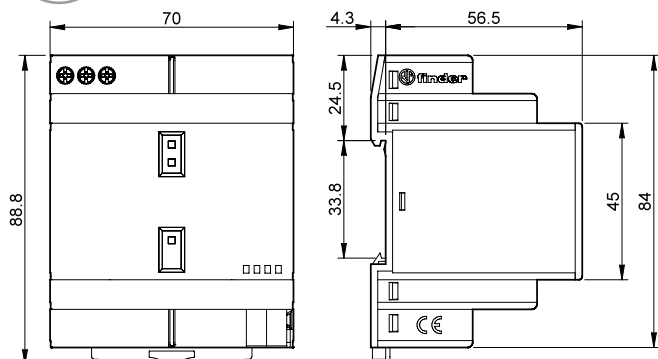

## Accessories

F



Sheet of marker tags (CEMBRE Thermal transfer printers), (48 tags), 6 x 12 mm

060.48

060.48



Identification tag, plastic, 1 tag, 17 x 25.5 mm (for 78.12/25/36/50/60/51/61)

019.01

019.01