



NM8, NM8S Moulded Case Circuit Breaker

1. General

- 1.1 Certificates: CE, DNV, KEMA, UKrSEPRO, EAC, RCC;
- 1.2 Electric ratings: AC50/60Hz, AC220V~690V
 16A~1600A;
- 1.3 Standard: IEC/EN 60947-2.

2. Operating conditions

- 2.1 Temperature: -5°C ~ +40°C; the average value within 24h shall not exceed +35°C; for the circuit breaker with thermo-magnetic release, +40°C is set to be the standard temperature for ratings. Special utilization, please refer to coefficients indicated on page 21 for temperature compensation correction;
- 2.2 Altitude: ≤ 2000m;
- 2.3 Pollution grade: Grade 3;
- 2.4 Air conditions:
 At mounting site, relative humidity not exceed 50% at the max temperature of +40°C, higher relative humidity is allowable under lower temperature. For example, RH could be 90% at +20°C, special measures should be taken to occurrence of dews.



3. Type designation

N M 8 □ - □ □ □ □ □ □ □ □ □ □ □ □

Application code
 Blank: for power distribution;

M: for motor protection
 Number of poles: 2: 2-pole
 3: 3-pole
 4: 4-pole
 With current release components,
 N-pole makes and breaks with other three poles, N-pole first makes then breaks, N-pole operating value is 1.0In of other three poles

Rated current :
 125: 16, 20, 25, 32, 40, 50, 63, 80, 100, 125
 250: 100, 125, 160, 180, 200, 225, 250
 400: 250, 315, 350, 400
 630: 250, 315, 350, 400, 500, 630 (for thermo-magnetic breaker, the rated operational current be up to 500A)
 800: 630, 700, 800
 1250: 630, 700, 800, 1000, 1250
 1600: 1000, 1250, 1600 (Only electronic products)

Breaking capacity code:
 S: Standard type; (current limiting technology utilised)
 H: Higher type; (current limiting technology utilised)
 R: Current limiting type (current limiting technology utilised)

Frame size rated current: 125, 250, 400,
 630, 800, 1250, 1600

Release type code:
 Blank: thermal-magnetic release;
 S: Electronic release;

Design sequence number

MCCB

Company code

4. Product overview

NM8 Moulded Case Circuit Breaker

- 1 Body
- 2 Thermo magnetic release
- 3 Electronic release
- 4 Plug-in base
- 5 Rotary manual operating handle
- 6 Motor driven operating mechanism
- 7 Under-voltage release
- 8 Shunt release
- 9 Alarm contact
- 10 Auxiliary contact
- 11 Front connection plate
- 12 Rear connection plate
- 13 Locking system(padlock)
- 14 Short terminal cover
- 15 Extended terminal cover
- 16 DIN rail adaptor
- 17 Cage clamp terminal
- 18 Mechanical interlock

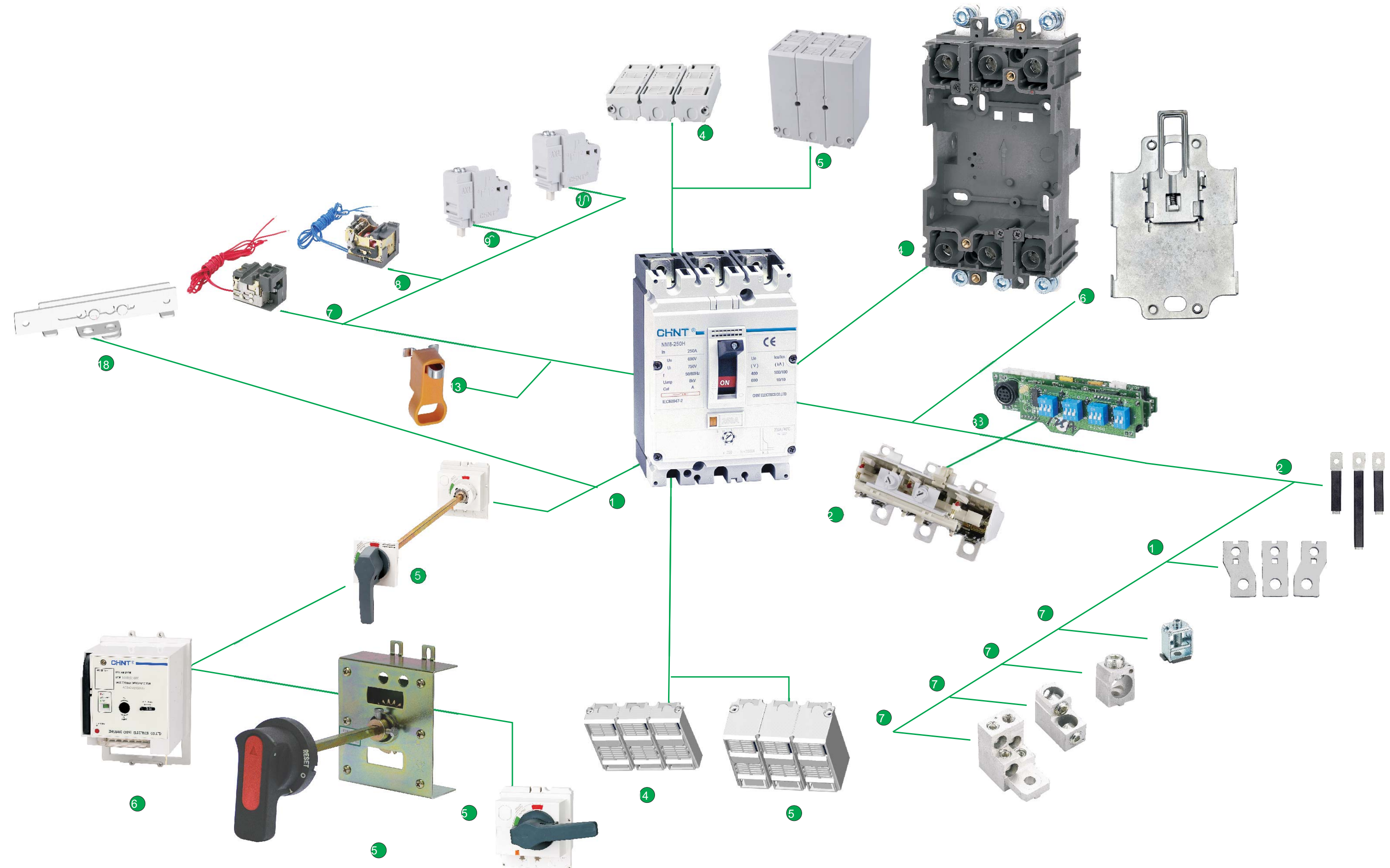

5. Technical data
5.1 Parameters

NM8 circuit breaker Thermal-magnetic type		NM8-125						NM8-250						NM8-400						NM8-630						NM8-800						NM8-1250											
4 Frames		Frame 1						Frame 2						Frame 3						Frame 4						Frame 4																	
Electric characteristics as per IEC 60947-2 and EN60947-2																																											
Rated current(A)	In	16, 20, 25, 32, 40, 50, 63, 80, 100, 125												100, 125, 160, 180, 200, 225, 250						250, 315, 350, 400						250, 315, 350, 400, 500						630, 700, 800						630, 700, 800, 1000, 1250					
Rated insulation voltage (V)	Ui	800																																									
Rated impulse withstand voltage (kV)	Uimp	8																																									
Rated operational voltage (V)	Ue	690																																									
		AC 50/60Hz																																									
		DC																																									
Number of poles		2		3		4		2		3		4		3		4		3		4		3		4		3		4		3		4											
Breaking capacity code		H S H R S H																																									
Rated ultimate short-circuit breaking capacity (kA RMS) Icu	AC 380V/400V/415V	100 50 100 150 50 100																																									
	AC 660V/690V	8 8 8 8 8																																									
Rated service breaking capacity Ics= (%Icu)		100																																									
Suitability for isolation		■																																									
Utilization category		A																																									
Safety of insulation		■																																									
Life(CO recycle)	Mechanical	20,000						20,000						15,000						15,000						10,000						10,000											
	Electrical	10,000						10,000						6,000						6,000						6,000						6,000											
Protection		Thermo-magnetic																																									
Release units		■																																									
Over-load protection		■																																									
Short-circuit protection		■																																									
Residual current protection	Added on residual current protection module	-																																									
Mounting and connection																																											
Fixed	Front connection	■																																									
	Rear connection	■																																									
DIN rail	Front connection	-																																									
Plug-in	Front connection	■																																									
	Rear connection	■																																									
Manual	Handle	■																																									
	Direct or extended rotary handle	■																																									
Motor-driven mechanism		■																																									
Manual, remote operated automatic source changeover systems		■																																									
Shunt and under-voltage release		■																																									
Auxiliary and alarm contact		■																																									
Pad locking system		■																																									
Mounting and connection accessories																																											
Connection terminal		■																																									
Front connection plate		■																																									
Rear connection plate		■																																									
DIN rail adaptor		-																																									
Plug-in type connection accessories		■																																									
Terminal covers		■																																									
Interphase barrier		■																																									
Dimension and weight																																											
Dimension(mm)W×H×L	Fixed type-front connection	62×140×79	90×140×79	120×140×79	70×157×88	105×157×88	140×157×88	140×255×113	185×255×113	140×255×113	185×255×113	210×370×196	280×370×196	210×370×196	280×370×196																												
Weight(kg)	Fixed type-front connection	0.85	1.2	1.6	1.5	2.1	2.8	7.5	10	7.5	10	17.5	23	17.5	23																												

Note: ① When Ue is ≥660V, Ics=50% Icu.

NM8S circuit breaker Electronic type		NM8S-125						NM8S-250						NM8S-400						NM8S-630①						NM8S-800						NM8S-1250						NM8S-1600											
3 Frames		Frame 1						Frame 2						Frame 2						Frame 3						Frame 3																							
Electric characteristics as per IEC 60947-2 and EN60947-2																																																	
Rated current(A)	In	40, 50, 63, 80, 100, 125												100, 125, 160, 180, 200, 225, 250						250, 315, 350, 400						250, 315, 350, 400, 500, 630						630, 700, 800						630, 700, 800, 1000, 1250						1000, 1250, 1600					
Rated insulation voltage (V)	Ui	800																																															
Rated impulse withstand voltage (kV)	Uimp	8																																															
Rated operational voltage (V)	Ue	690																																															
		AC 50/60Hz																																															
		DC																																															
Number of poles		3		4		4		3		4		3		4		3		4		3		4		3		4		3		4		3		4															
Breaking capacity code		S H																																															
Rated ultimate short-circuit breaking capacity (kA RMS) Icu	AC 380V/400V/415V	70 100																																															
	AC 660V/690V	10 10																																															
Rated service breaking capacity Ics= (%Icu)		100																																															
Suitability for isolation		■																																															
Utilization category		A																																															
Safety of insulation		■																																															
Life(CO recycle)	Mechanical	20,000						15,000						15,000						10,000						10,000																							
	Electrical	20,000						6,000						6,000						4,000						4,000																							
Protection		Electronic																																															
Release units		■																																															
Over-load protection		■																																															
Short-circuit protection		■																																															
Residual current protection	Added on residual current protection module	-																																															
Mounting and connection																																																	
Fixed	Front connection	■																																															
	Rear connection	■																																															
DIN rail	Front connection	-																																															
Plug-in	Front connection	■																																															
	Rear connection	■																																															
Manual	Handle	■																																															
	Direct or extended rotary handle	■																																															
Motor-driven mechanism		■																																															
Manual, remote operated automatic source changeover systems		■																																															
Shunt and under-voltage release		■																																															
Auxiliary and alarm contact		■																																															
Pad locking system		■																																															
Mounting and connection accessories																																																	
Connection terminal		■																																															
Front connection plate		■																																															
Rear connection plate		■																																															
DIN rail adaptor		-																																															
Plug-in type connection accessories		■																																															
Terminal covers		■																																															
Interphase barrier		■																																															
Dimension and weight																																																	
Dimension(mm)W×L×H	Fixed type-front connection	105×157×88	140×157×88	140×255×113	185×255×113	140×255×113	185×255×113	210×370×196	280×370×196	210×370×196	280×370×196																																						
Weight(kg)	Fixed type-front connection	2.1	2.8	8	11	8	11	17.5	23	17.5	23																																						

Note: ① The rated current of NM8S-630 plug-in type up to 570A.

5.2 The following table shows which connection diagram to use according to the number of poles to be connected in series to obtain the required breaking capacity, in relation to the type of distribution network:

Rated voltage V	protection function	Isolation	Earth-insulated network	Network with one polarity ⁽¹⁾ earthed	Network with a middle point earthed
≤250	■	■	A	A	A
	■	-	-	-	-
≤500	■	■	A	B	A
	■	-	-	C	-

Note:

a The risk of double earth fault is nil, therefore the fault current only involves a part of the interruption poles.

b For connection with four poles in series, circuit-breakers with neutral at 100% of the phase settings must be used.

6. Release

6.1 Thermo-magnetic release

6.1.1 Thermo-magnetic release of NM8-125, 250, 400, 630, 800 and 1250 breakers can be set to meet protection requirements

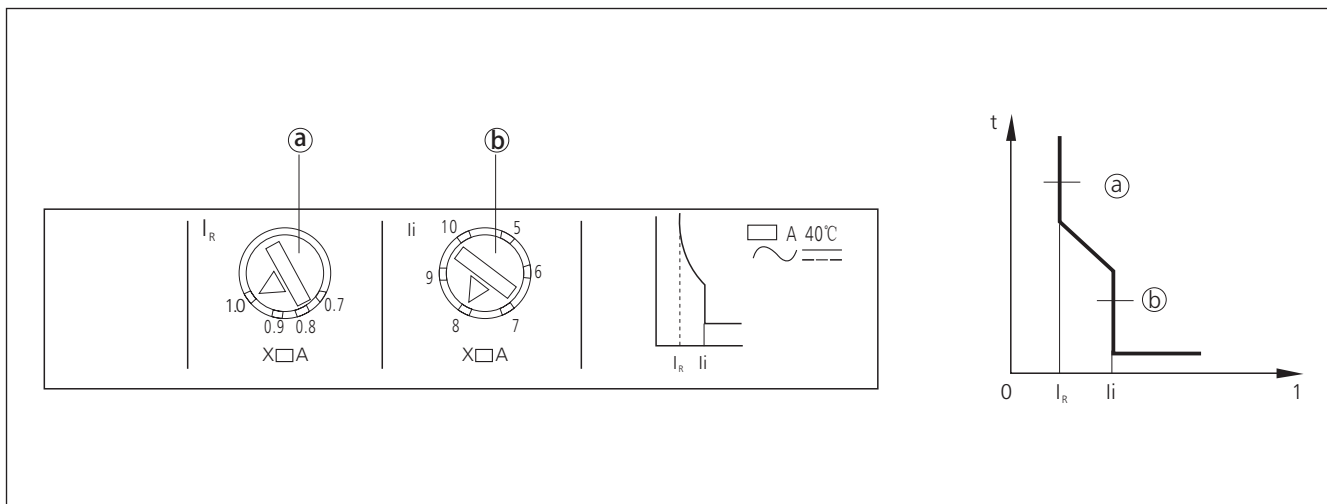

Adjustable setting of over-load protection (a)

Adjustable setting of short-circuit protection or fixed (b)

Thermo-magnetic release	NM8-125	NM8-250	NM8-400	NM8-630	NM8-800	NM8-1250
Rated value (A) In 40°C	16, 20, 25, 32, 40, 50, 63, 80, 100, 125	100, 125, 160, 180, 200, 225, 250	250,315, 350, 400	250, 315, 350, 400, 500	630, 700, 800	630, 700, 800, 1000, 1250
Over-load protection	Thermo protection					
Tripping current IR (A)	Adjustable range (0.8~1)XIn	Adjustable range (0.7~1)XIn	Adjustable range (0.7~1)XIn	Adjustable range (0.7~1)XIn	Adjustable range (0.8~1)XIn	Adjustable range (0.8~1)XIn
N-pole protection (A) 4A, 4B 4C, 4D	Without protection 1.0XIn	Without protection 1.0XIn	Without protection 1.0XIn	Without protection 1.0XIn	Without protection 1.0XIn	Without protection 1.0XIn
Short-circuit protection	Magnetic protection					
Tripping current Ii (A)	10In (for power distribution protection) 12In (for motor protection)	Adjustable range (5~10) XIn (8~12)In(for motor protection)	Adjustable range (5~10) XIn (8~12)In(for motor protection)	Adjustable range (5~10) XIn (8~12)In(for motor protection)	Adjustable range (5~10) XIn (8~12)In(for motor protection)	Adjustable range (5~10)XIn (8~12)In(for motor protection)

NM8-250, (100~180)A: adjustable magnetic protection value=(6~10)In, (200~250)A: adjustable magnetic protection value=(5~10)In

6.1.2 Characteristic of thermo protection operation of thermo-magnetic release for power distribution

Serial No.	Test current	I/In	Conventional time	Initial status
1	Conventional non-tripping current	1.05	> 1h (In ≤ 63A) > 2h (In > 63A)	Cold status
2	Conventional tripping current	1.3	≤ 1h (In ≤ 63A) ≤ 2h (In > 63A)	Right after test 1

6.1.3 Characteristic of thermo protection operation of thermo-magnetic release for motor protection

Serial No.	Test current	I/In	Conventional time	Initial status
1	Conventional non-tripping current	1.0	> 2h	Cold status
2	Conventional tripping current	1.2 1.5 7.2	≤ 2h ≤ 4min 4s ≤ T ≤ 10s	Right after test 1

6.2 Electronic Release

6.2.1 NM8S-125, 250 electronic release is an universal module. It is of 11 current specifications: 40A, 50A, 63A, 80A, 100A, 125A, 160A, 180A, 200A, 225A and 250A to adjust setting values and to meet protection requirements.

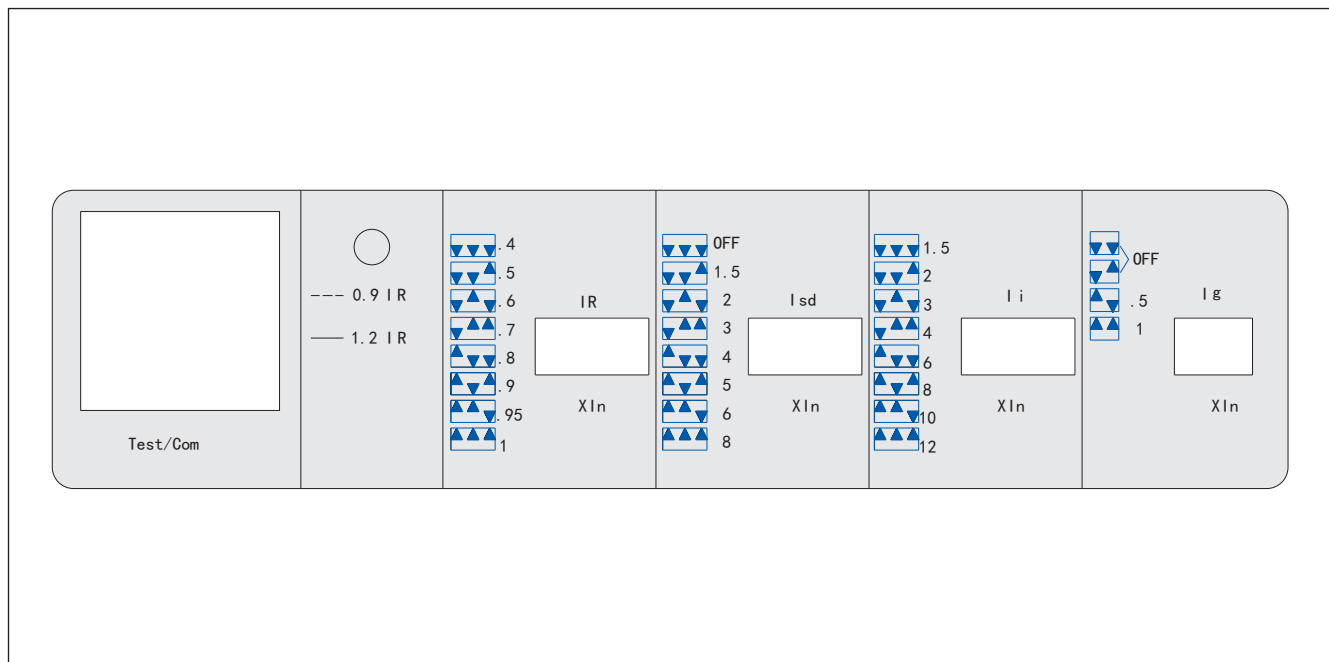

The indicator light flashes, when single-phase operational current is $\leq 90\% I_R$.
 The indicator light is always lit, when single-phase operational current is $\geq 115\% I_R$.

Electronic release	NM8S-125	NM8S-250
Rated value I_n (A) 20~70°C	40, 50, 63, 80, 100, 125	100, 125, 160, 180, 200, 225, 250
Over-load protection	Thermal protection	
Tripping current I_R	Adjustable range 0.4, 0.5, 0.6, 0.7, 0.8, 0.9, 0.95, 1XIn	Adjustable range 0.4, 0.5, 0.6, 0.7, 0.8, 0.9, 0.95, 1XIn
Tripping time	$1.05 I_R$ >2h non tripping $1.3 I_R$ ≤ 1 h $1.5 I_R$ 96s $6 I_R$ 6s	$1.05 I_R$ >2h non tripping $1.3 I_R$ ≤ 1 h $1.5 I_R$ 96s $6 I_R$ 6s
N-line protection tripping current I_g	Adjustable range OFF, 0.5, 1XIn	Adjustable range OFF, 0.5, 1XIn
Tripping current I_i	Adjustable range 1.5, 2, 3, 4, 6, 8, 10, 12XIn	Adjustable range 1.5, 2, 3, 4, 6, 8, 10, 12XIn
Short time-delay short current protection tripping current I_{sd}	Adjustable range OFF, 1.5, 2, 3, 4, 6, 8XIn	Adjustable range OFF, 1.5, 2, 3, 4, 6, 8XIn

6.2.2 NM8S-400, 630 electronic release is an universal module.
 It is of 6 current specifications: 250A, 315A, 350A, 400A, 500A,
 and 630A to adjust setting values and to meet protection requirements.
 The release is of wide setting range and multi-functional modules
 can be selected. NM8S-400, 630 electronic release.

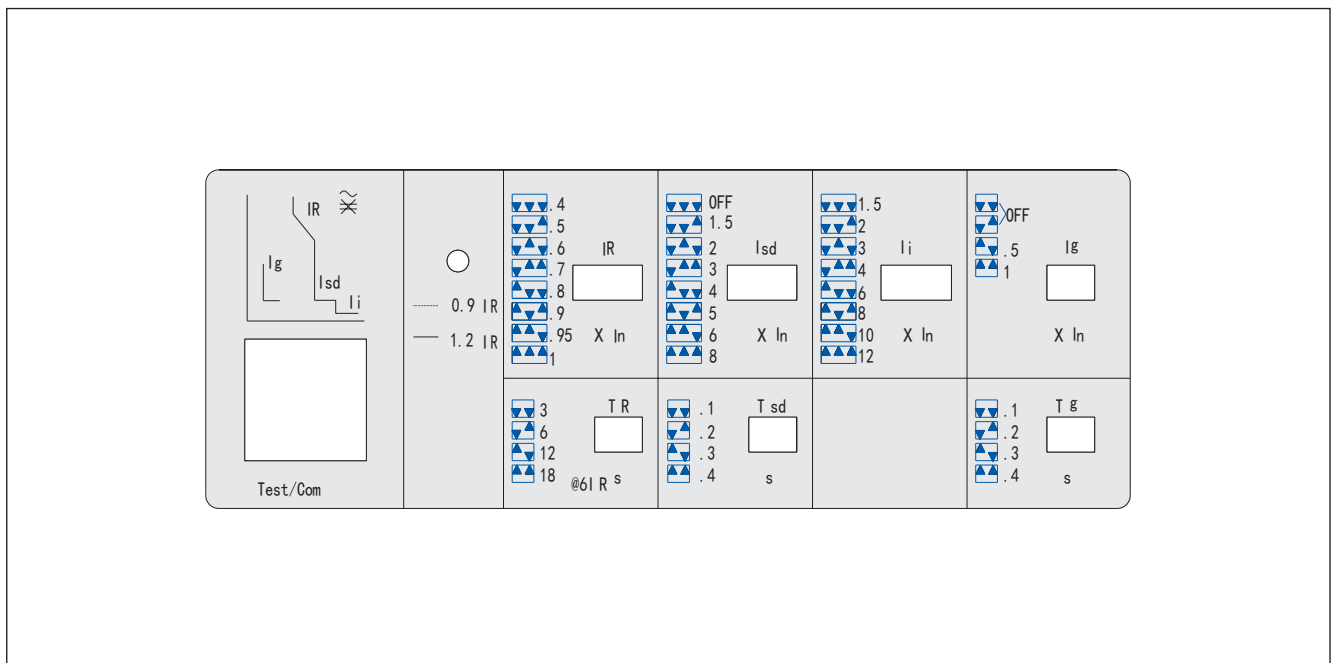

6.2.3 NM8S-800, 1250, 1600 electronic release is an universal module. It is of 6 current specifications: 630A, 700A, 800A, 1000A, 1250A and 1600A to adjust setting values and to meet protection requirements. The release is of wide setting range and multi-functional modules can be selected.

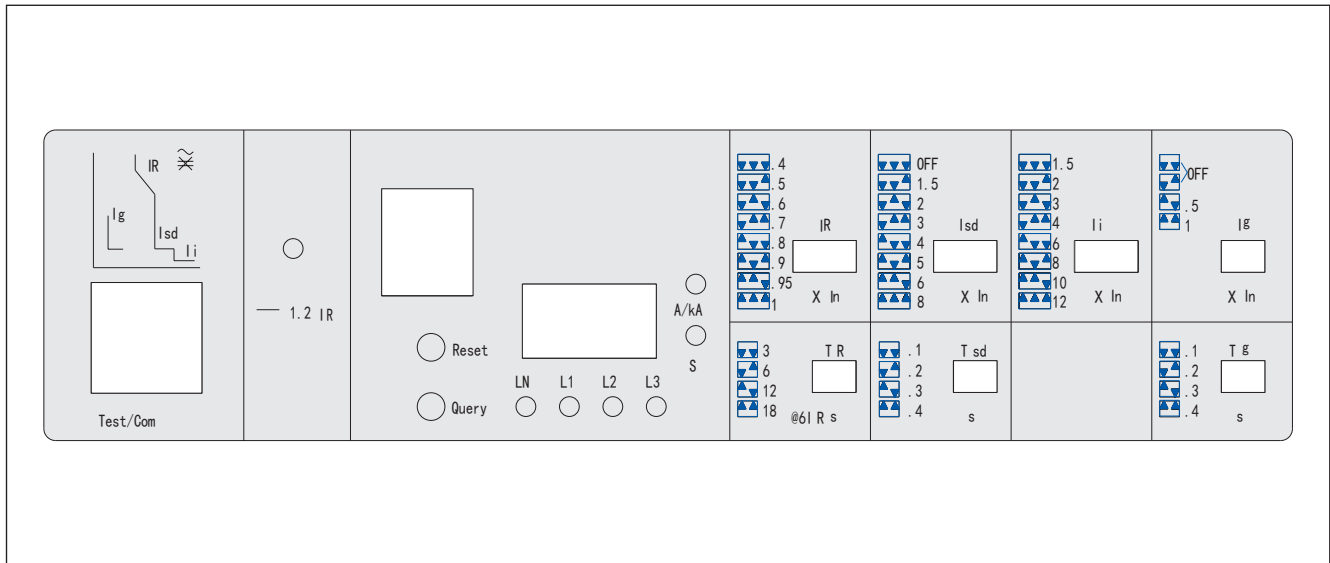

Tripping current I_R , I_{sd} , I_i should be set with three-digit switch or rotary knob as per current.

- I_R setting of over-load protection
 I_R could be adjusted as per customers' requirements,
 and TR, tripping time at the status of 6I_R can be set as per customers' requirements.

Model	1.05 I_R	1.3 I_R	1.5 I_R (s)	2.0 I_R (s)	6 I_R (s)
NM8S-400, 630	>2h non-tripping	<1h tripping	48,96, 192, 288	27, 54, 108, 162	3, 6, 12, 18
NM8S-800,1250,1600	>2h non-tripping	<1h tripping	48, 96, 192, 288	27, 54, 108, 162	3, 6, 12, 18

● I_r indicator light for over-load status indication

The indicator light flashes, when single-phase operational current is $< 90\% I_r$

The indicator light is always lit, when single-phase operational current is $\geq 115\% I_r$

● I_{sd} setting of short-circuit protection and tripping time

Setting value of current I_{sd} could be adjusted as per customers' requirements and OFF stands for status without ST protection;

T_{sd} the tripping time could be adjusted as per customers' requirements.

● I_i setting of short-circuit protection

Value of setting current could be adjusted as per customers' requirements

● I_g setting of protection operations

As a 4P circuit breaker with N-line protection, setting value of current I_g could be adjusted as per customers' requirements and OFF stands for status without protection of N-pole; T_g , the operating time of N-pole could be adjusted as per customers' requirements.

Electronic release	NM8S-400	NM8S-630	NM8S-800	NM8S-1250	NM8S-1600
Rated value A In 20~70°C	250, 315, 350, 400	250, 315, 350, 400, 500, 630	630, 700, 800	630, 700, 800, 1000, 1250	1000, 1250, 1600
long time-delay over-load protection (thermal protection)					
Tripping current I_r (A)	Adjustable range 0.4, 0.5, 0.6, 0.7, 0.8, 0.9, 0.95, 1XIn	Adjustable range 0.4, 0.5, 0.6, 0.7, 0.8, 0.9, 0.95, 1XIn	Adjustable range 0.4, 0.5, 0.6, 0.7, 0.8, 0.9, 0.95, 1XIn	Adjustable range 0.4, 0.5, 0.6, 0.7, 0.8, 0.9, 0.95, 1XIn	Adjustable range 0.4, 0.6, 0.7, 0.8, 0.9, 0.95, 1In
Tripping time $6I_r$ (s)	Adjustable range 3, 6, 12, 18	Adjustable range 3, 6, 12, 18	Adjustable range 3, 6, 12, 18	Adjustable range 3, 6, 12, 18	Adjustable range 3, 6, 12, 18
short time-delay short-circuit protection					
Tripping current I_{sd} (A)	Adjustable range OFF, 1.5, 2, 3, 4, 5, 6, 8XIn	Adjustable range OFF, 1.5, 2, 3, 4, 5, 6, 8XIn	Adjustable range OFF, 1.5, 2, 3, 4, 5, 6, 8XIn	Adjustable range OFF, 1.5, 2, 3, 4, 5, 6, 8XIn	Adjustable range OFF, 1.5, 2, 3, 4, 5, 6, 8In
Tripping time T_{sd} (s)	Adjustable range 0.1, 0.2, 0.3, 0.4	Adjustable range 0.1, 0.2, 0.3, 0.4	Adjustable range 0.1, 0.2, 0.3, 0.4	Adjustable range 0.1, 0.2, 0.3, 0.4	Adjustable range 0.1, 0.2, 0.3, 0.4
(Instantaneous) short-circuit protection					
Tripping current I_i (A)	Adjustable range .5, 2, 3, 4, 6, 8, 10, 12XIn 12In(for motor protection)	Adjustable range 1.5, 2, 3, 4, 6, 8, 10, 12XIn 12In(for motor protection)	Adjustable range 1.5, 2, 3, 4, 6, 8, 10, 12XIn 12In(for motor protection)	Adjustable range 1.5, 2, 3, 4, 6, 8, 10, 12XIn 12In(for motor protection)	Adjustable range 1.5, 2, 3, 4, 6, 8, 10, 12XIn 12In(for motor protection)
(N-line) protection					
Tripping current I_g (A)	Adjustable range OFF, 0.5, 1XIn	Adjustable range OFF, 0.5, 1XIn	Adjustable range OFF, 0.5, 1XIn	Adjustable range OFF, 0.5, 1XIn	Adjustable range OFF, 0.5, 1XIn
Tripping time T_g (s)	Adjustable range 0.1, 0.2, 0.3, 0.4	Adjustable range 0.1, 0.2, 0.3, 0.4	Adjustable range 0.1, 0.2, 0.3, 0.4	Adjustable range 0.1, 0.2, 0.3, 0.4	Adjustable range 0.1, 0.2, 0.3, 0.4

7. Curves

7.1 Tripping curve (ambient temperature +40°C)

NM8-125(16A, 20A)

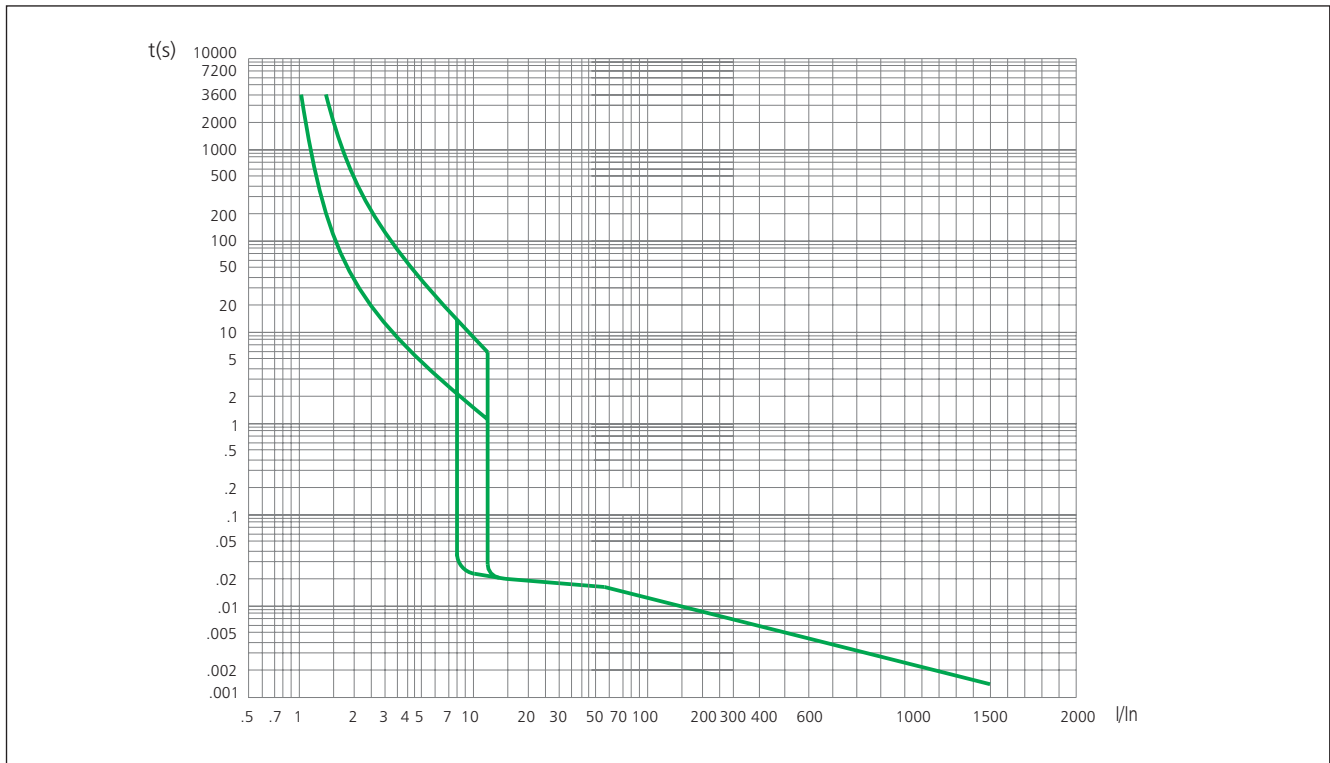

NM8-125(25A, 32A)

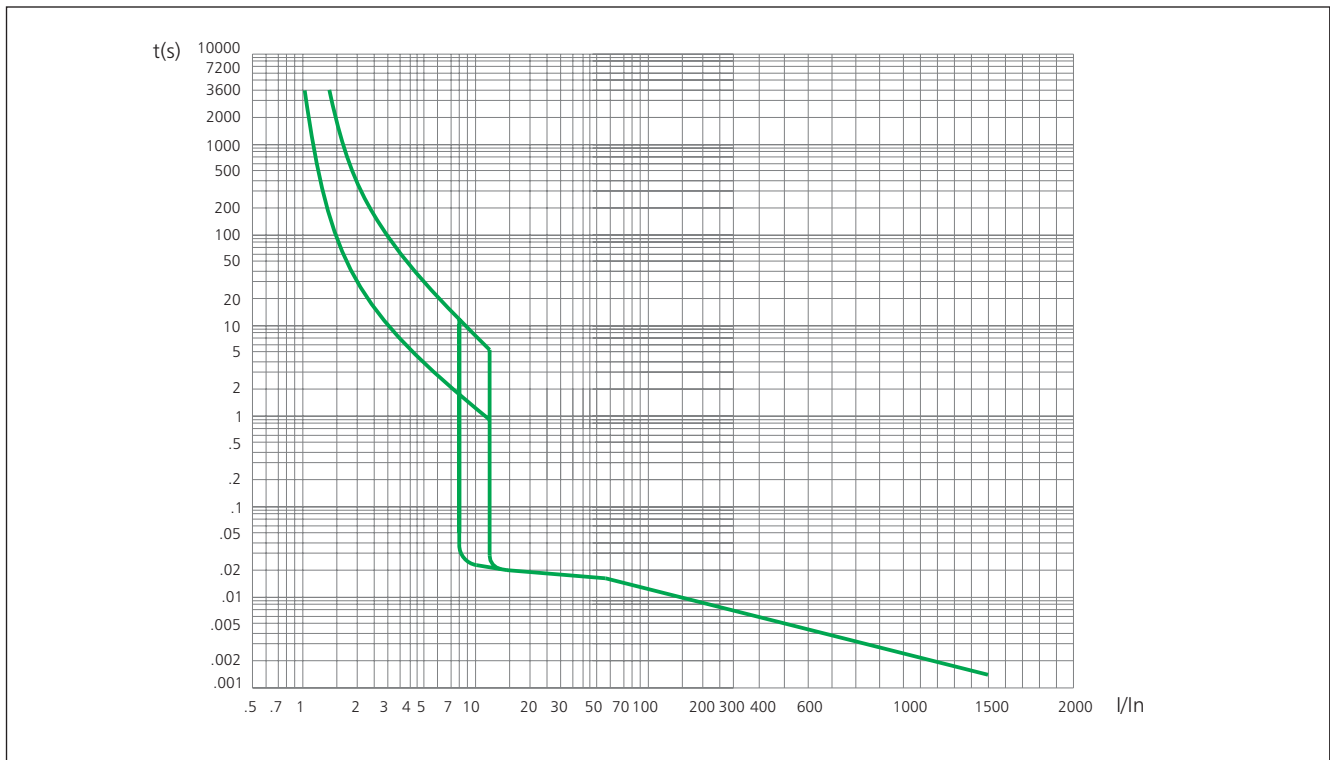

NM8-125(40A, 50A, 63A)

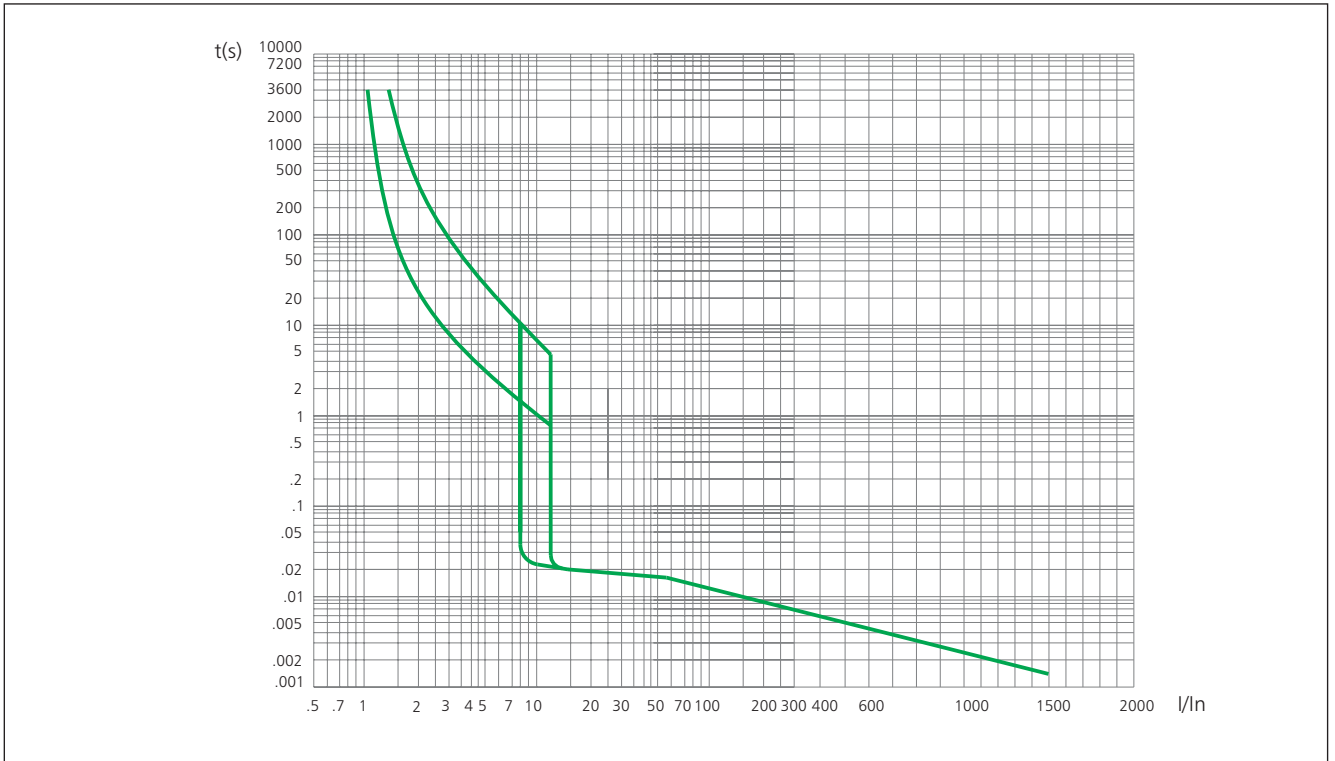

NM8-125(80A, 100A)

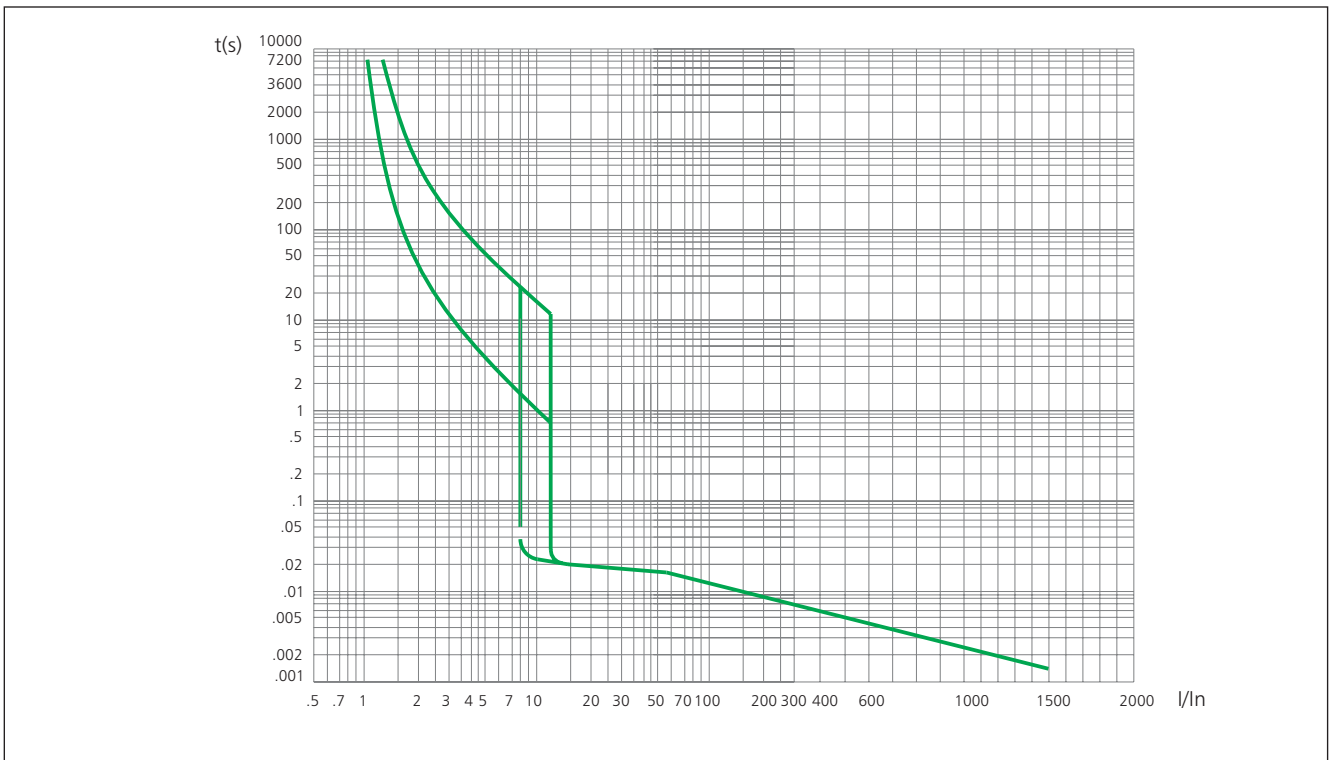

NM8-125(125A)

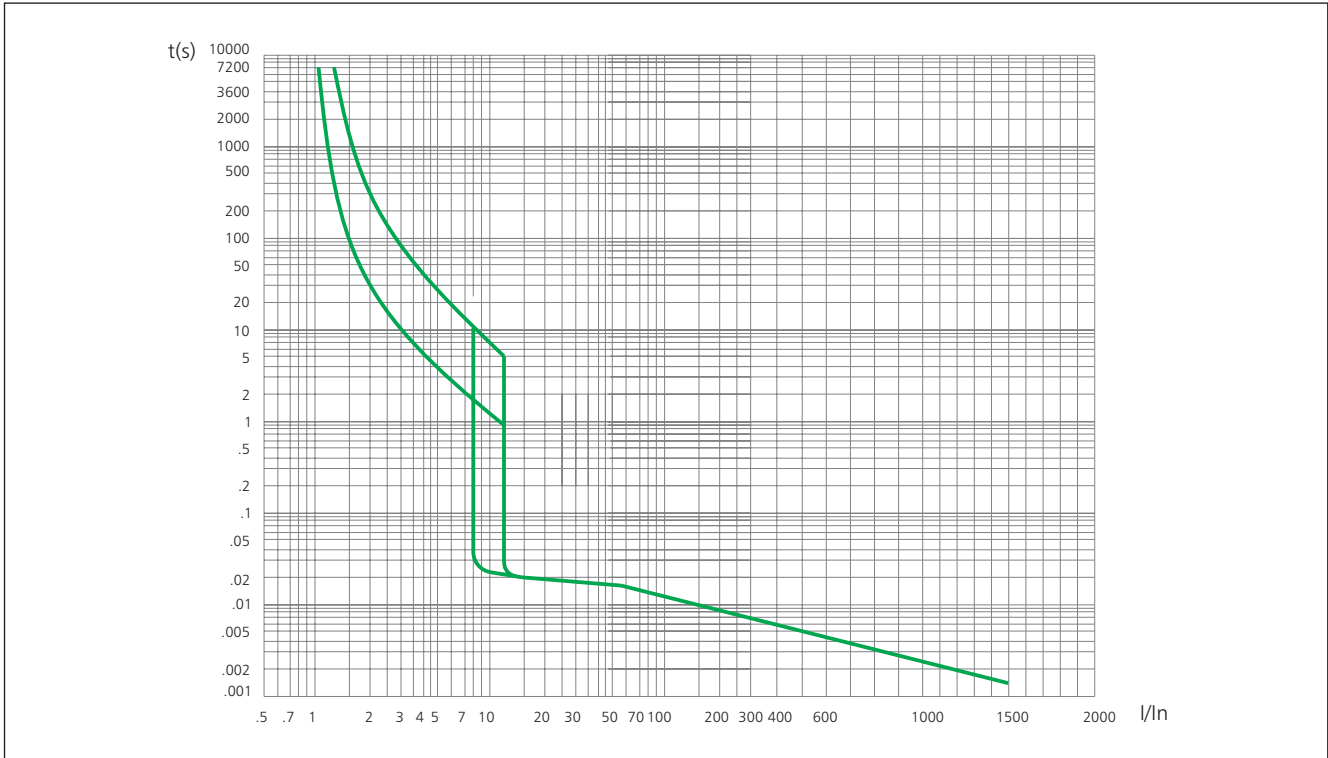

NM8-250(100A, 125A)

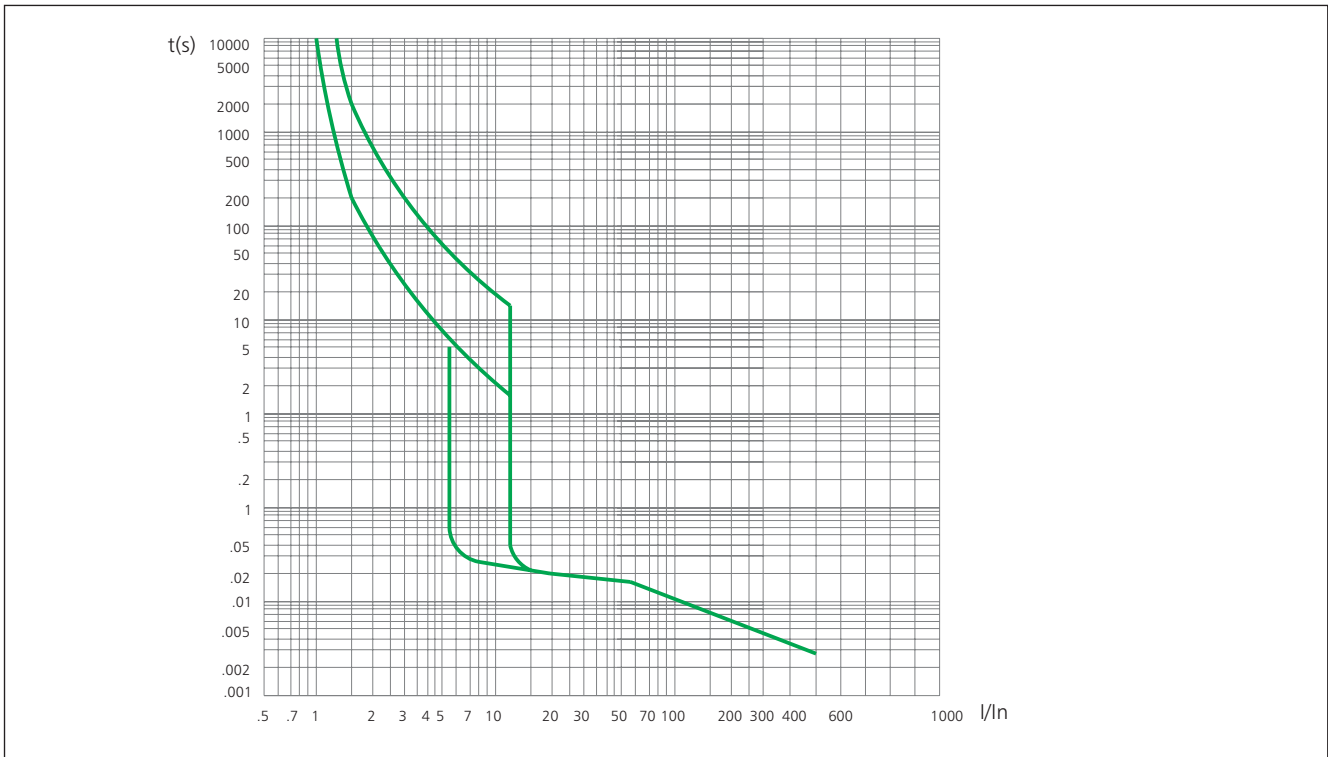

NM8-250(160A, 180A)

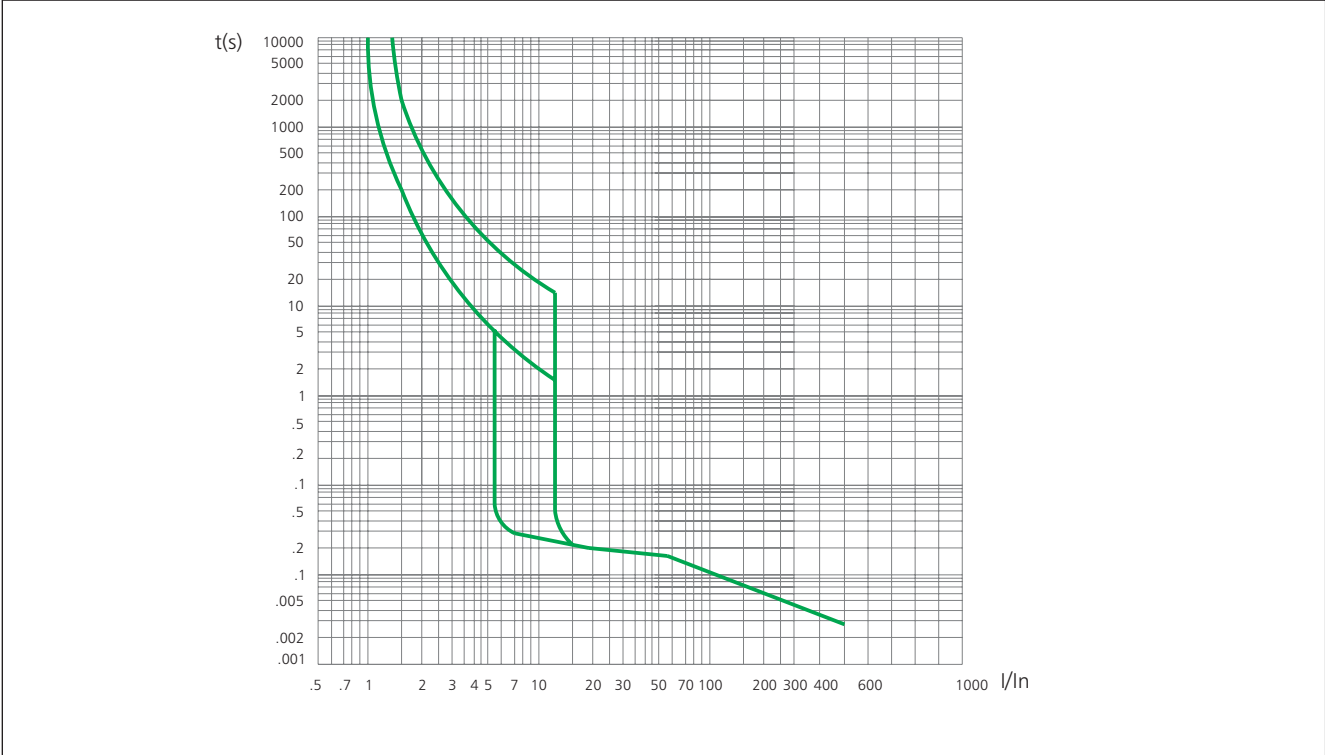

NM8-250(200A, 225A, 250A)

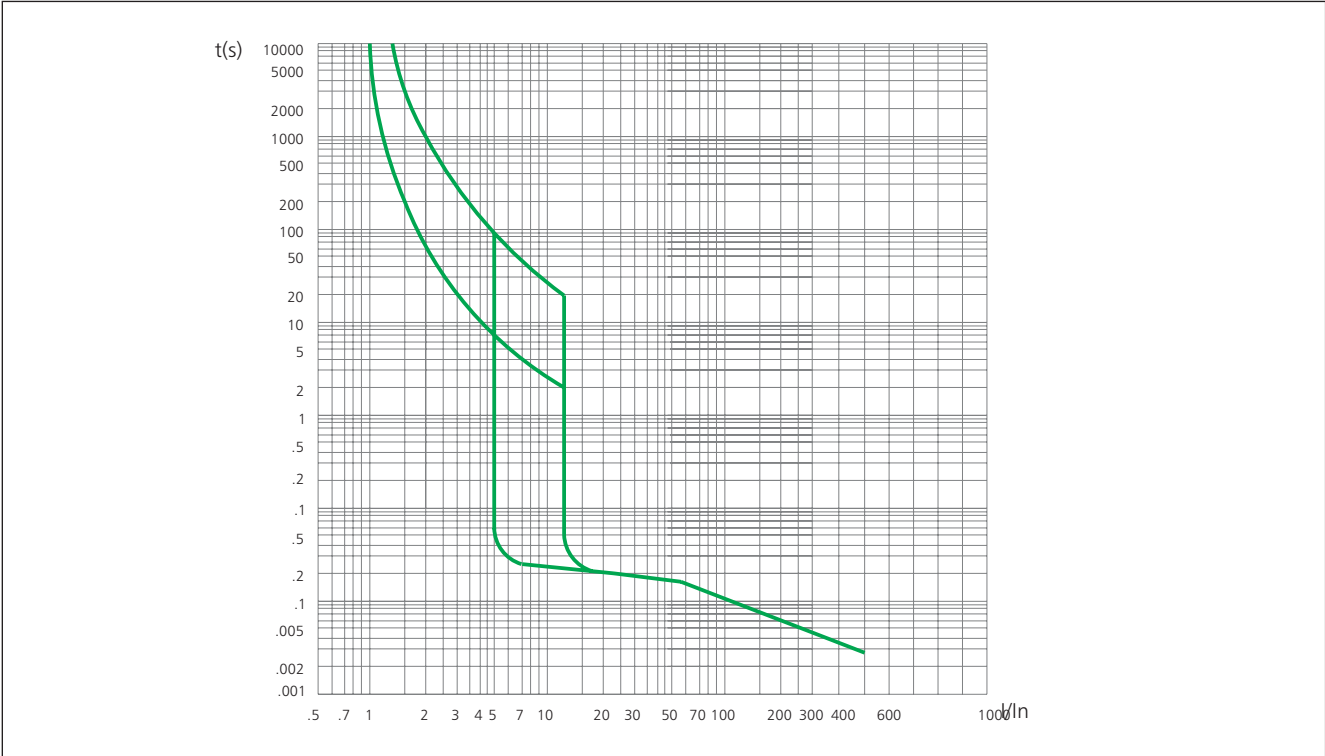

NM8-400, 630(250A~500A)

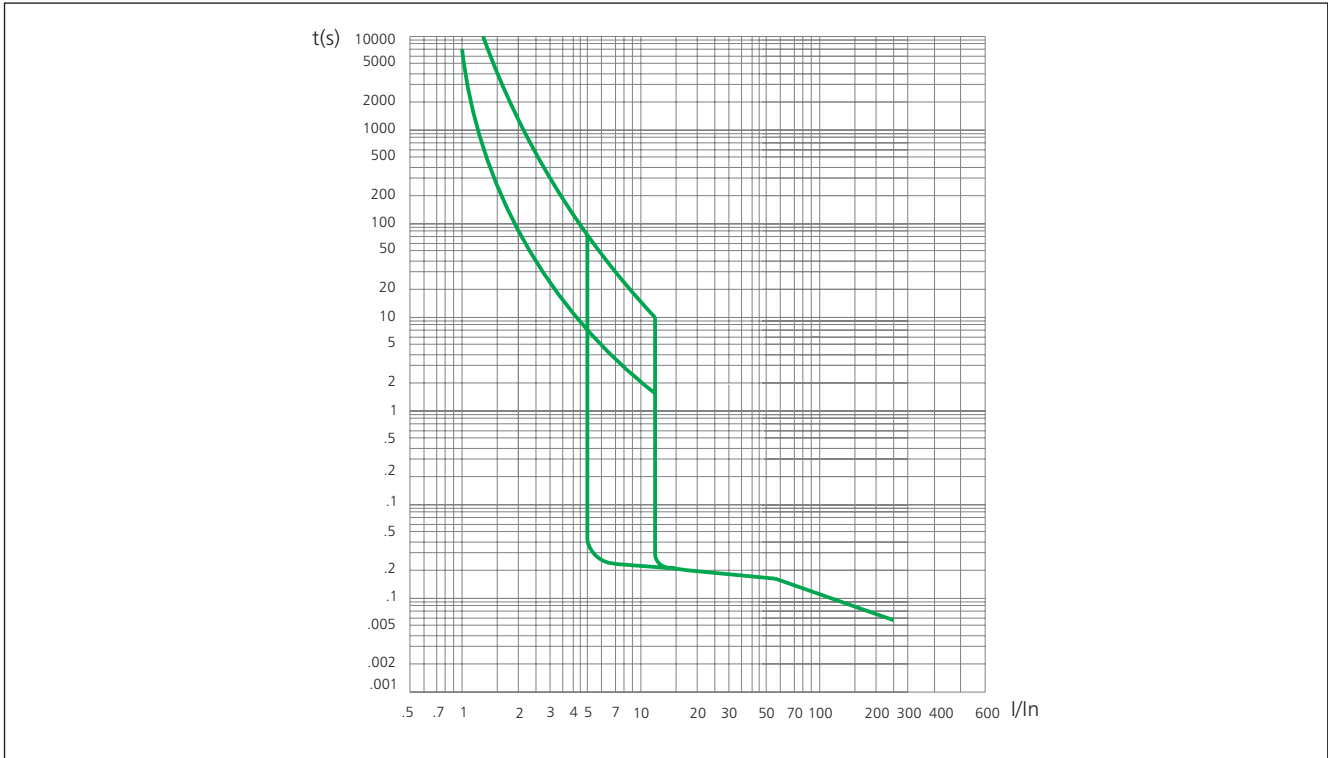

NM8-800(630A, 700A, 800A)
NM8-1250(630A, 700A, 800A, 1000A, 1250A)

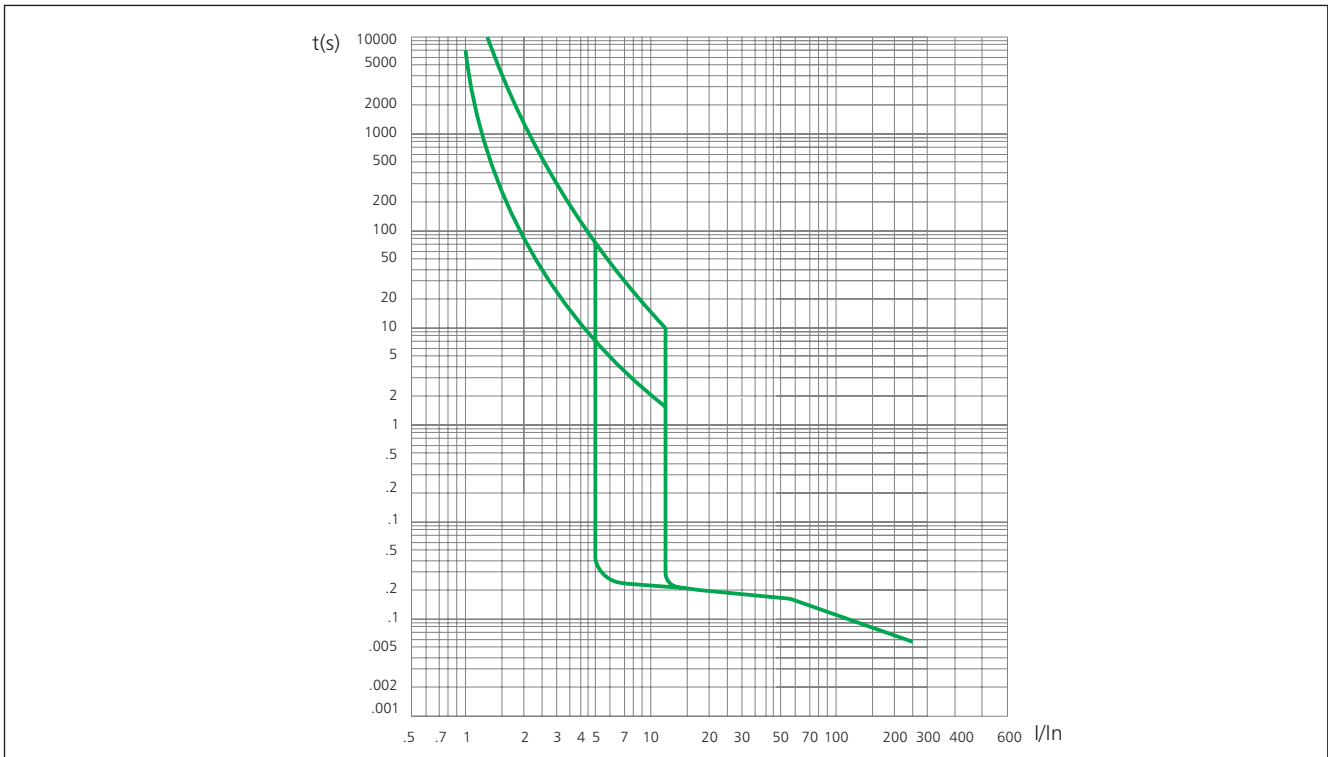

Relé de protección de motor NM8-125, 250, 400, 630(16A~500A)

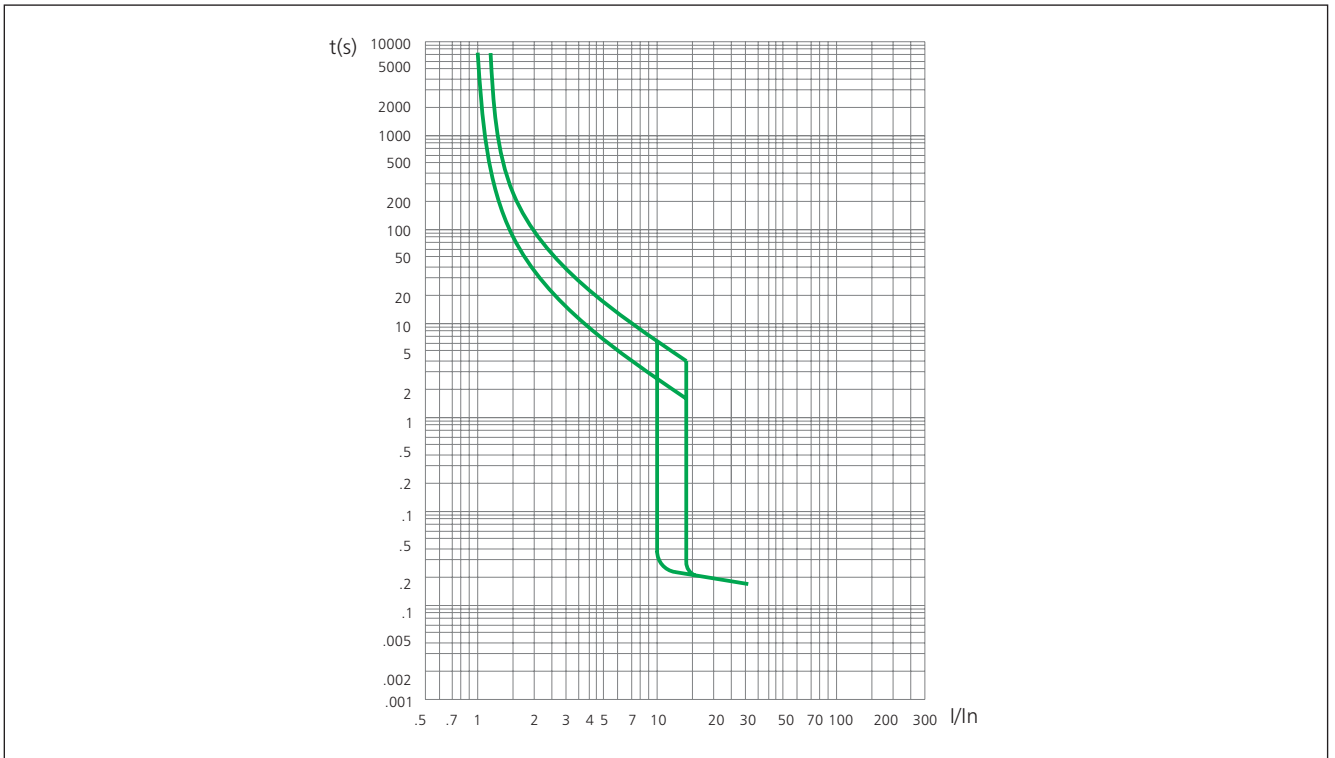

Relé electrónico NM8S-125, 250(40A~250A)

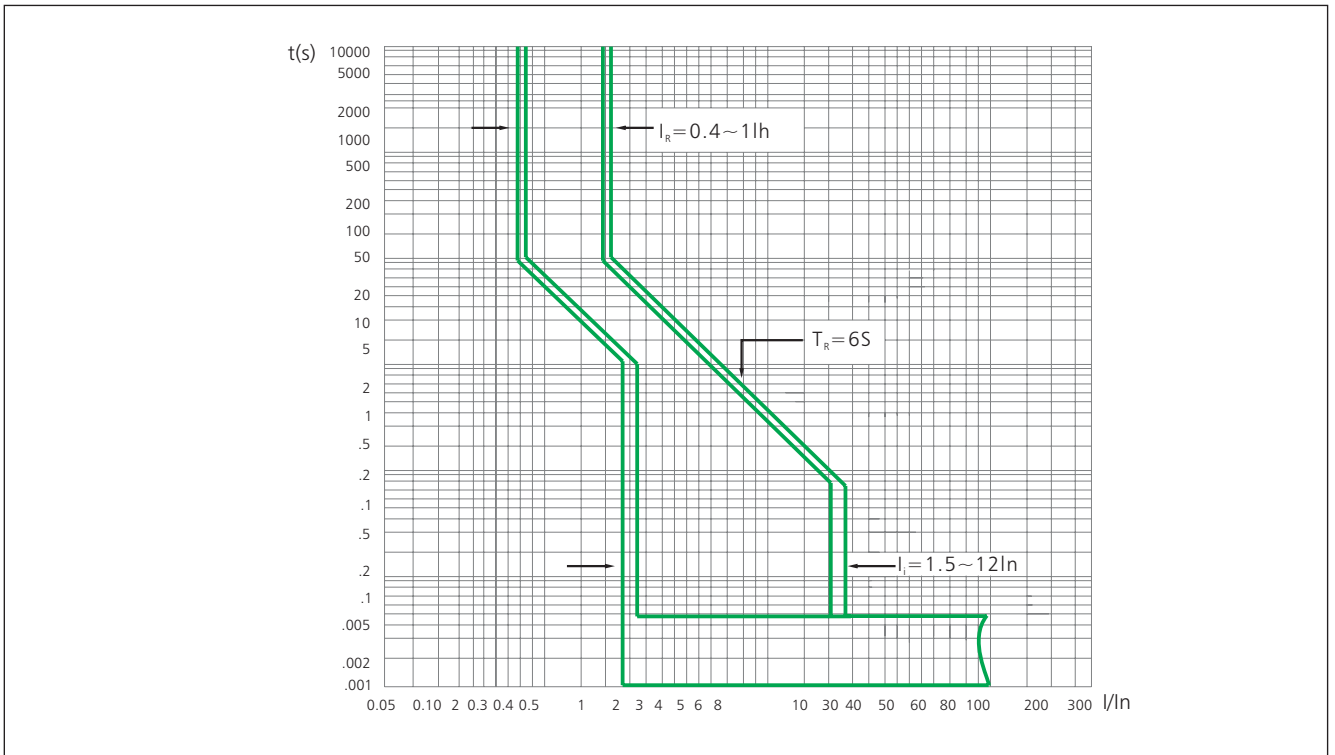

Intelligent release NM8S-400, 630(250A~630A)
NM8S-800, 1250, 1600(630A~1600A)

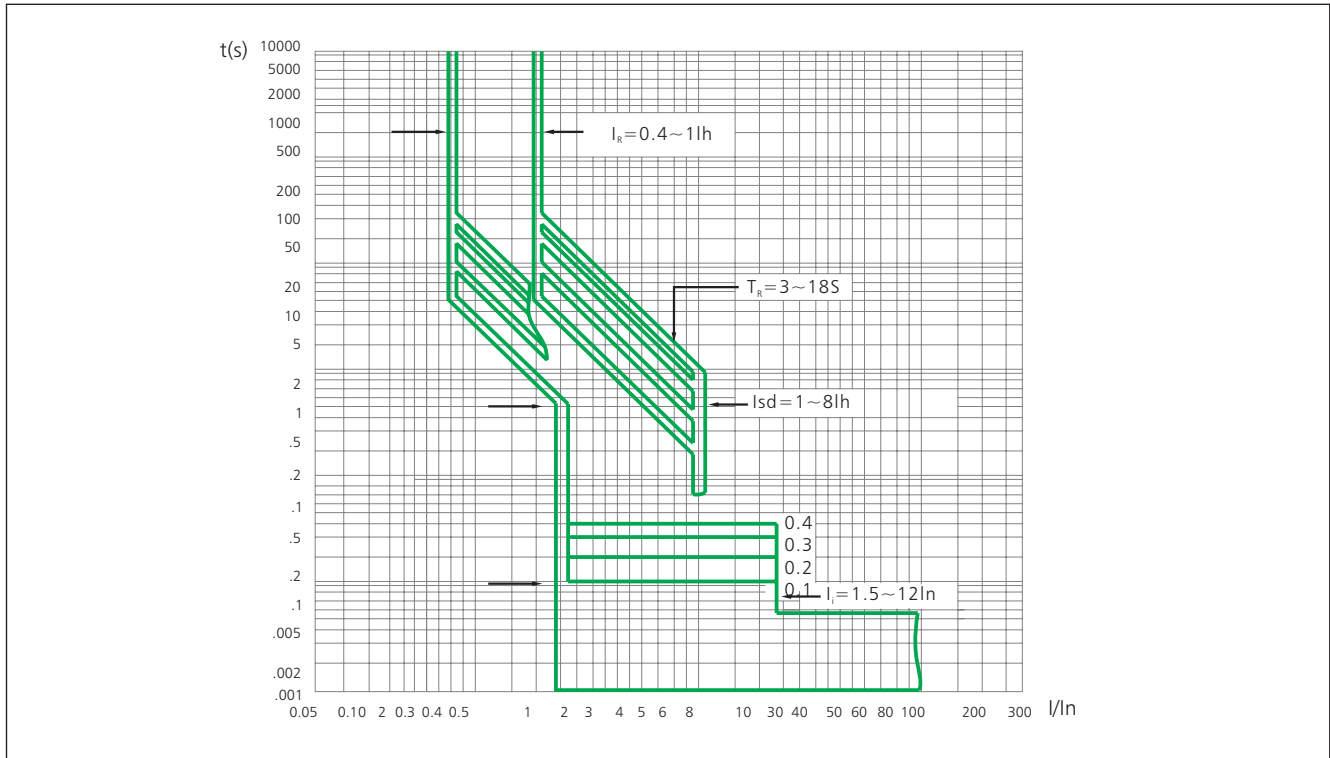

7.2 Temperature compensation

When the ambient temperature slightly changes, tripping characteristics will change as well, please refer to the table below for temperature compensation correction.

7.2.1 Temperature compensation coefficient of breaker with thermo-magnetic release as follows.

Ambient temperature	0°C	5°C	10°C	15°C	20°C	25°C	30°C	35°C	40°C	45°C	50°C	55°C	60°C	65°C	70°C
Temperature compensation coefficient	1.2	1.175	1.15	1.125	1.1	1.075	1.05	1.025	1.0	0.975	0.95	0.925	0.90	0.875	0.85

Note: For reference only

7.2.2 Temperature compensation coefficient of breaker with electronic release as follows

Frame Level rated current	0°C	5°C	10°C	15°C	20°C	25°C	30°C	35°C	40°C	45°C	50°C	55°C	60°C	65°C	70°C
NM8S-125S/H(40~125)	1	1	1	1	1	1	1	1	1	1	1	1	1	1	1
NM8S-250S/H(125~160)	1	1	1	1	1	1	1	1	1	1	1	1	1	1	1
NM8S-250S/H(200~250)	1	1	1	1	1	1	1	1	1	1	1	0.95	0.95	0.90	0.90
NM8S-630S/H/R(250~400)	1	1	1	1	1	1	1	1	1	1	1	0.98	0.95	0.93	0.90
NM8S-630S/H/R(500~630)	1	1	1	1	1	1	1	1	1	0.98	0.95	0.93	0.90	0.88	0.85
NM8S-1250S/H/R(630~800)	1	1	1	1	1	1	1	1	1	0.975	0.975	0.95	0.95	0.925	0.925
NM8S-1250S/H/R(1000~1250)	1	1	1	1	1	1	1	1	1	0.95	0.9	0.875	0.80	0.80	0.80
NM8S-1600S/H/R(1000~1600)	1	1	1	1	1	1	1	1	1	0.95	0.9	0.875	0.80	0.80	0.80

8. Mounting of circuit breaker

8.1 Modes of down-lead

Two modes of upper and lower down-lead are available; adoption of different down-lead modes will not affect normal operation of breaker, in addition, it is no need for derating.

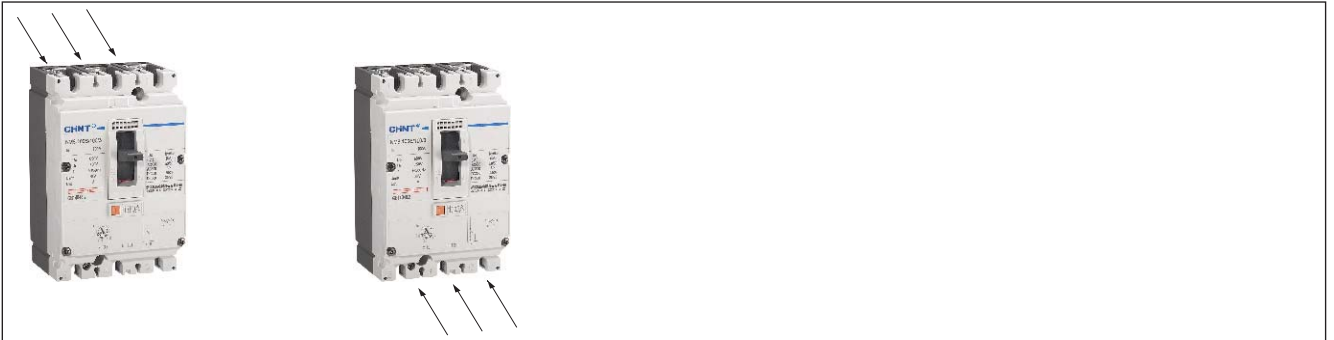

8.2 Modes of mounting

Mounting modes following are available for fixed and plug-in type breakers.

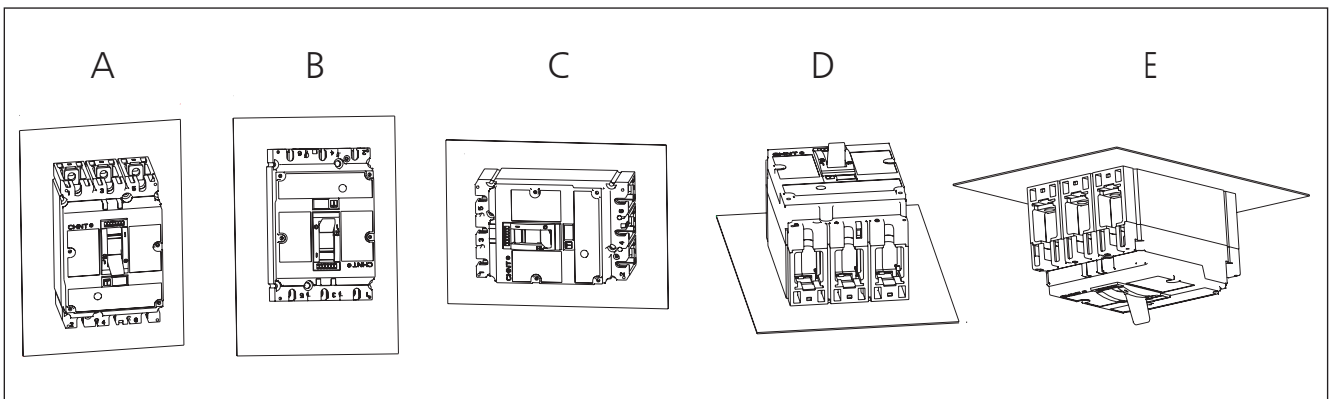

8.3 Modes of fixing

8.3.1 Fixing modes following are available for fixed and plug-in type breakers.

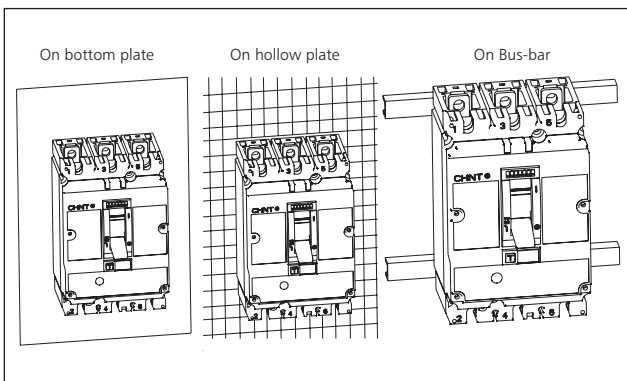

8.3.2 Fixing mode following is available for NM8(S)-125, 250 for fixed type breakers, which adopts DIN rail adaptor of front connection.

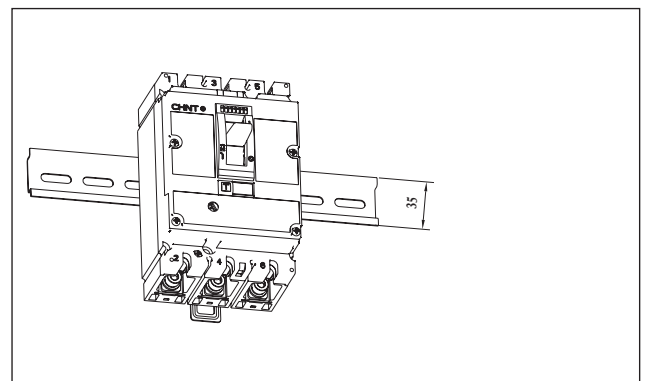

8.4 Secured distance

8.4.1 Min. Distance between breakers

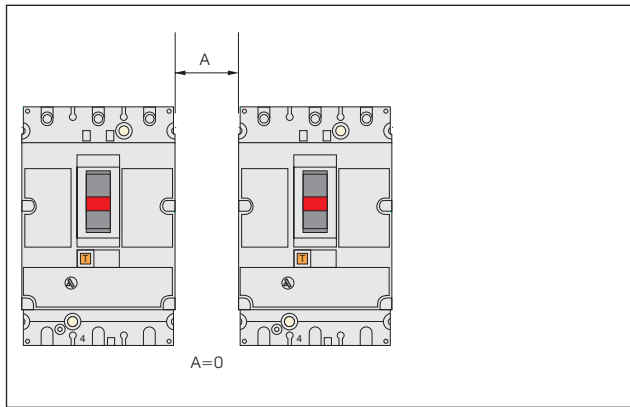

8.4.2 Min. distance between breaker and surface of switchgear where the operation handle is exposed.

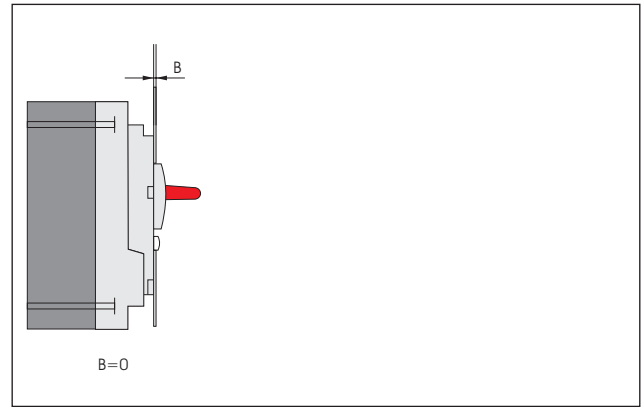

8.4.3 Min. distance between breaker and side of switchgear

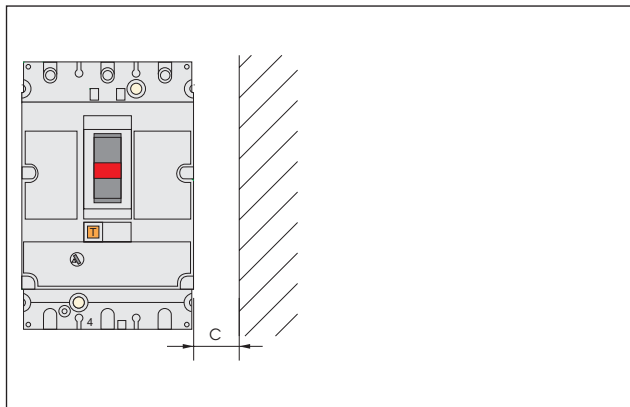

8.4.4 Min. distance between top and bottom of breaker

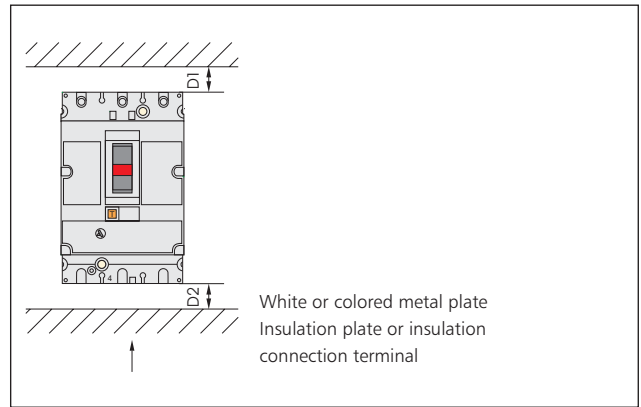

NM8 Breaker	Ue	C	Insulation plate or insulation connection terminal(mm)		White or colored metal plate(mm)	
			D1	D2	D1	D2
NM8-125	Ue ≤ 440V	10	30	30	35	35
	Ue < 600V	20	30	30	35	35
NM8S-125	Ue ≥ 600V	30	30	30	35	35
	Ue ≤ 440V	10	30	30	35	35
NM8-250	Ue < 600V	20	30	30	35	35
	Ue ≥ 600V	30	30	30	35	35
NM8S-250	Ue ≤ 440V	10	30	30	60	60
	Ue < 600V	20	30	30	60	60
NM8-400, 630,	Ue ≤ 440V	10	30	30	100	100
	Ue < 600V	20	30	30	100	100
NM8S-400, 630	Ue ≤ 440V	10	30	30	70	70
	Ue < 600V	20	30	30	70	70
NM8-800, 1250,	Ue ≤ 440V	10	130	100		
	Ue < 600V	20	130	100		
NM8S-800, 1250, 1600	Ue ≤ 440V	10	130	100		
	Ue < 600V	20	130	100		

Note: when voltage is ≥ 500V, extended terminal cover should be mounted

8.5 Modes of connection

8.5.1 Cable connection plug and Copper busbar

a. Screw is used to connect with copper (aluminum) cable connection plug or copper busbar

Size of connection screw

NM8-125: M6

NM8S-125, NM8-250, NM8S-250: M8

NM8-400, 630, NM8S-400, 630: M10

NM8-800, 1250, NM8S-800, 1250: M10

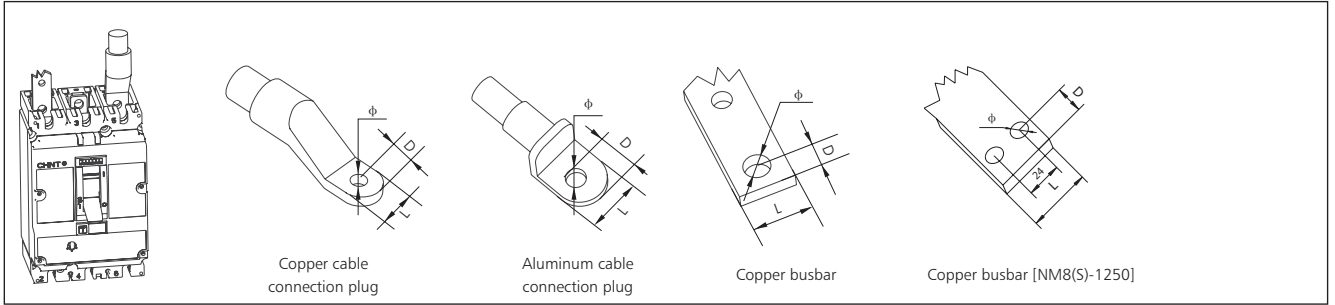

Dimension	NM8-125	NM8S-125 NM8-250 NM8S-250	NM8-400, 630 NM8S-400, 630	NM8-800, 1250 NM8S-800, 1250, 1600
Distance between different poles(mm)	30	35	45	70
L(mm)	≤ 15	≤ 25	≤ 32	≤ 50
D(mm)	≤ 7	≤ 10	≤ 16	≤ 16
φ (mm)	>6	>8	>10	>11

b. With front connection and use screw to connect with copper (aluminum) cable connection plate or copper busbar

Size of connection screw

NM8-125: M6

NM8S-125, NM8-250, NM8S-250: M8

NM8-400, 630, NM8S-400, 630: M12

NM8-800, 1250, NM8S-800,1250,1600: M10

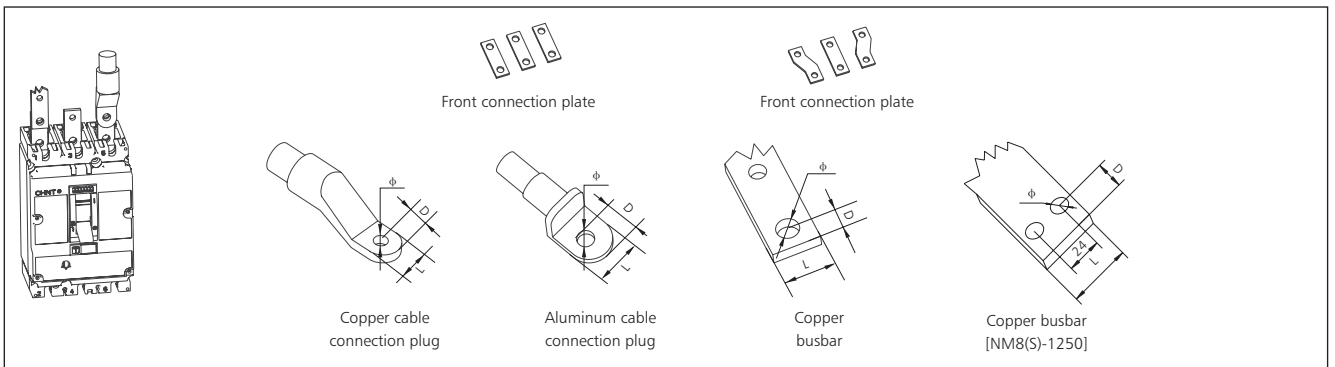

Dimension	NM8-125	NM8S-125 NM8-250 NM8S-250	NM8-400, 630 NM8S-400, 630		NM8-800, 1250 NM8S-800, 1250, 1600
Distance between different poles(mm)	30	35	52.5	70	70
L(mm)	≤ 15	≤ 25	≤ 40	≤ 60	≤ 50
D(mm)	≤ 7	≤ 10	≤ 20	≤ 20	≤ 16
φ (mm)	>6	>8	>12	>12	>11

8.5.2 Connection of bare cable

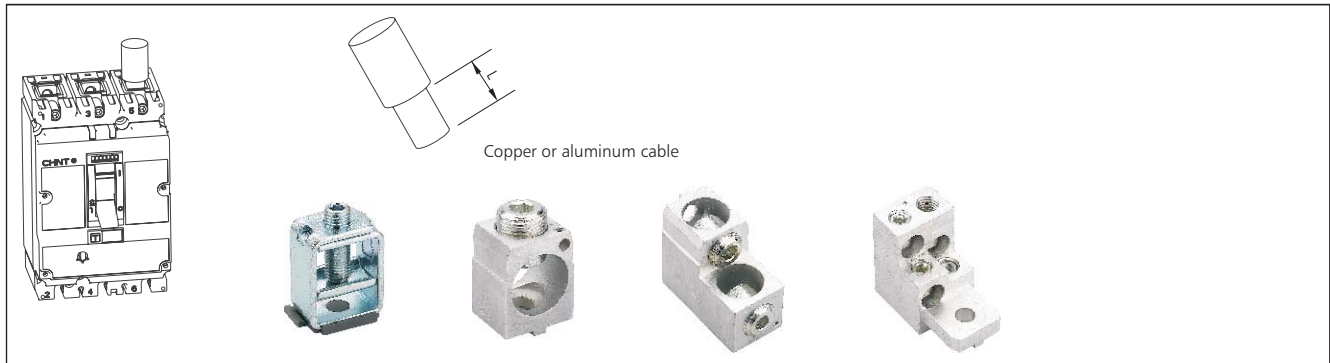

Dimension	NM8-125	NM8S-125 NM8-250 NM8S-250
L(mm)	16	20
CSA(mm ²)	2.5~50	2.5~185

Dimension	NM8-400, 630 NM8S-400, 630		
	1	2	4
Number of cable	1	2	4
L(mm)	26	30, 60	30
CSA(mm ²)	35~370	35~185	35~125

8.5.3 Rear connection

For rear connection, cable connection plug should be used for connection with copper busbar.

Rear connection

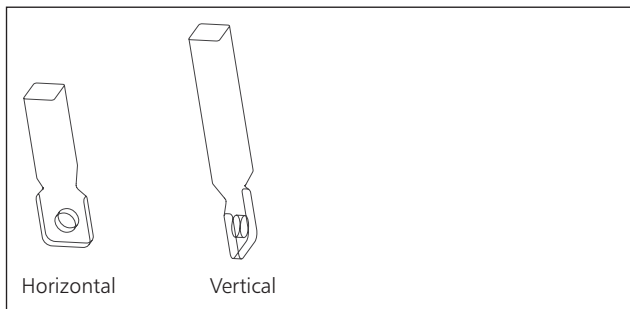

8.5.4 Plug-in type connection

Two modes of front and rear connection are available; for rear connection, upper limit or lower limit connection is used.

Plug-in type

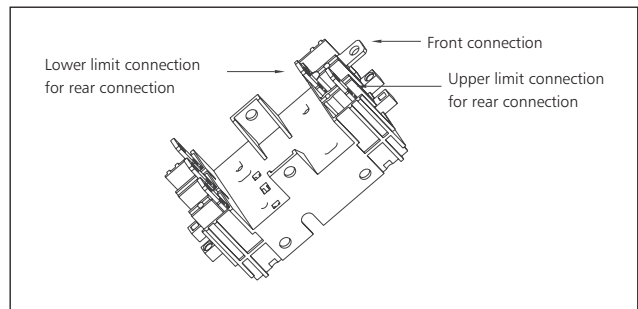

8.5.5 Standard CSA of copper cable or busbar used for connection

Rated current(A)		16	20	25	32	40	50	63	80	100	125	160	200	250	315	350	400	500	630	700	800	1000	1250	1600
Cross section area (mm ²)	Copper cable	2.5	2.5	4.0	6.0	10	10	16	25	35	50	70	95	120	185	185	240	2×150	2×185	2×240	2×240	-	-	-
	Copper busbar	-	-	-	-	-	-	-	-	-	-	-	-	-	-	-	-	2×30×5	2×40×5	2×50×5	2×50×5	2×60×5	2×80×5	2×80×5

8.5.6 Usual cross sections for conductors according intensity

In(A)	Copper conductors	Copper bar
	Cross Section Area (mm ²)	Dimensions Area (mm ²)
10	1.5	—
16	2.5	—
20	2.5	—
25	4	—
32	6	—
40	10	—
63	16	—
80	25	—
100	35	—
125	50	—
160	70	—
200	95	—
250	120	—
315	185	—
400	240	—
500	2×150	2×30×5
630	2×185	2×40×5
800	2×240	2×50×5
1000	—	2×60×5
1250	—	2×80×5
1600	—	2×80×5

8.6 Overall and Mounting Dimensions

8.6.1 Overall and mounting dimensions of fixed type for front connection

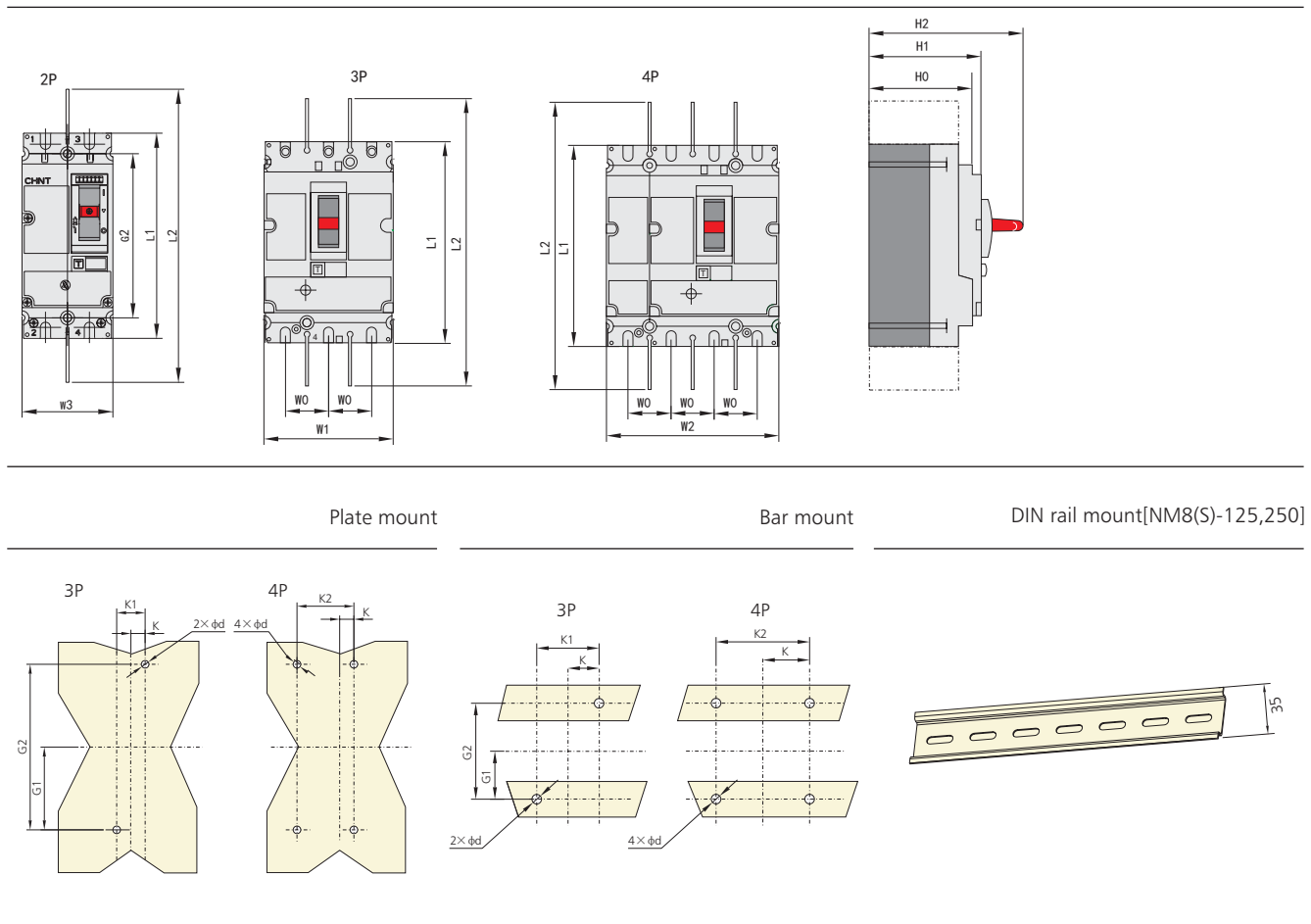

(mm)

Model	L1	L2	H0	H1	H2	K	K1	K2	G1	G2	W0	W1	W2	W3	d
NM8-125	140	243	72	79	108	15	30	60	56	112	30	90	120	62	5.5
NM8S-125/NM8-250/NM8S-250	157	273	82	88	126	17.5	35	70	62.5	125	35	105	140	70	5.5
NM8-400, 630/NM8S-400, 630	255	482	109	113	168	22.5	45	90	100	201.5	45	140	185	-	5.5
NM8-800, 1250/NM8S-800, 1250	370	565	141	145	206	35	70	140	120	240	70	210	280	-	7
NM8S-1600	370	565	137	151	211	35	70	140	120	240	70	210	280	-	7

8.6.2 Overall and mounting dimensions of fixed type for rear connection

Plate mount

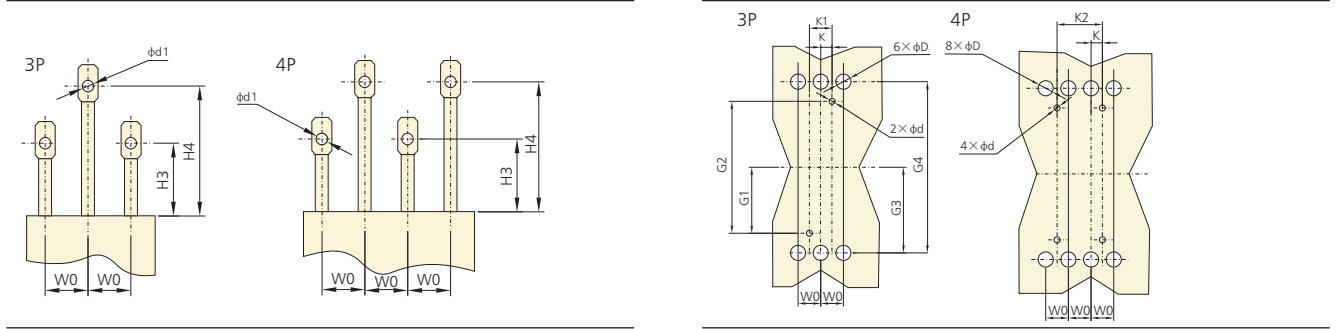

(mm)

Model	H3	H4	W0	K	K1	K2	G1	G2	G3	G4	d	d1	D
NM8-125	47	87	30	15	30	60	56	112	63	126	5.5	6.5	15
NM8S-125/NM8-250/NM8S-250	57	97	35	17.5	35	70	62.5	125	72	140	5.5	8	20
NM8-400/NM8S-400	56	100	45	22.5	45	90	100	200	113.5	227	6	13	32
NM8-630/NM8S-630	56	100	45	22.5	45	90	100	200	113.5	227	6.5	13	32

8.6.3 Overall and mounting dimension of plug-in type

Plate mount

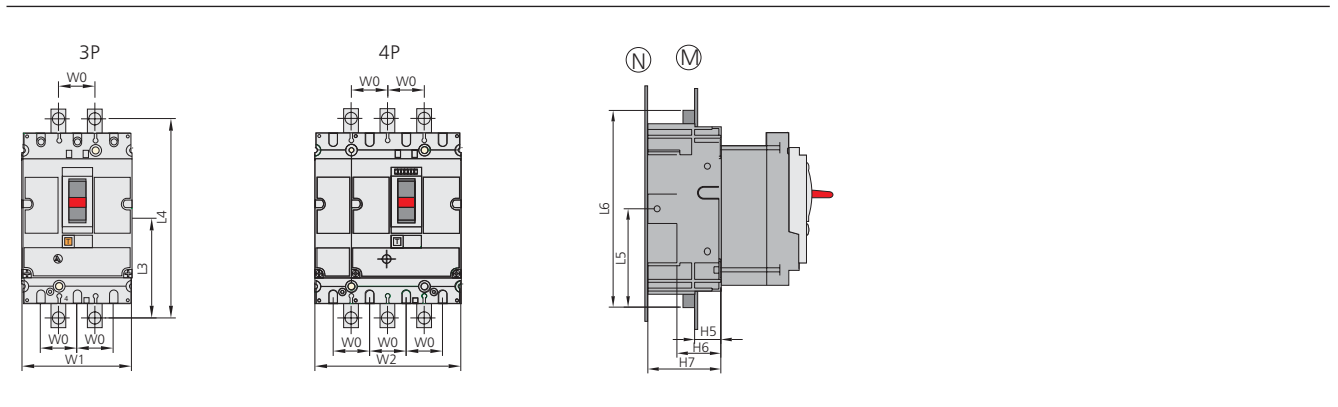
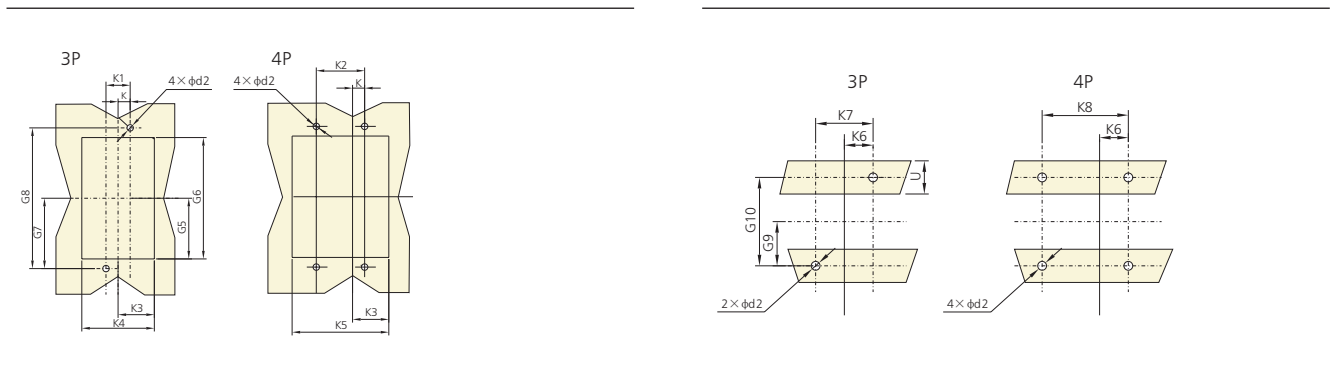

Plate mount

Bar mount



Moulded Case Circuit Breakers NM8, NM8S

Plate mount (N) front connection
Insulation barrier must be mounted
between mounting plate and breaker base

(standard configuration)
Plate mount (N) rear connection
Mounting plate and breaker base must be used with insulation material

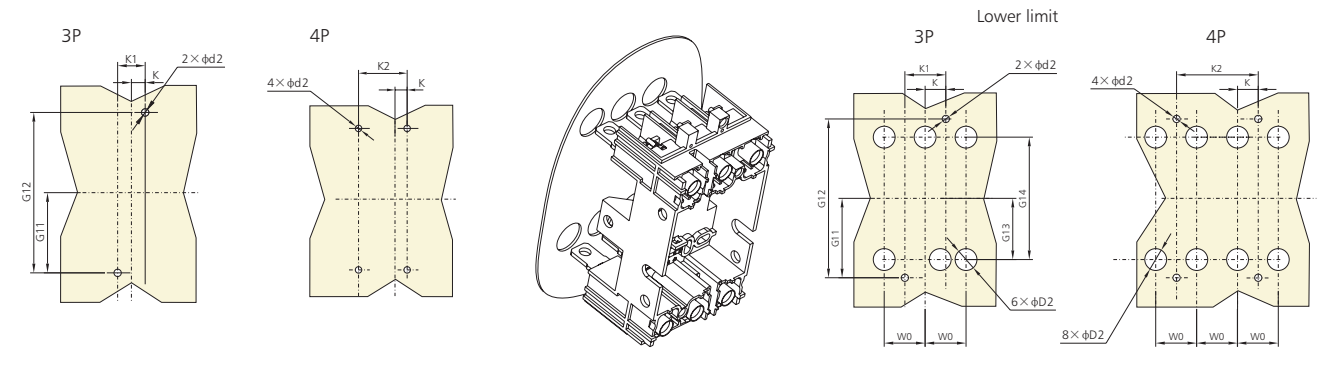

Note: Plug-in type rear connection, use insulated mounting base plate

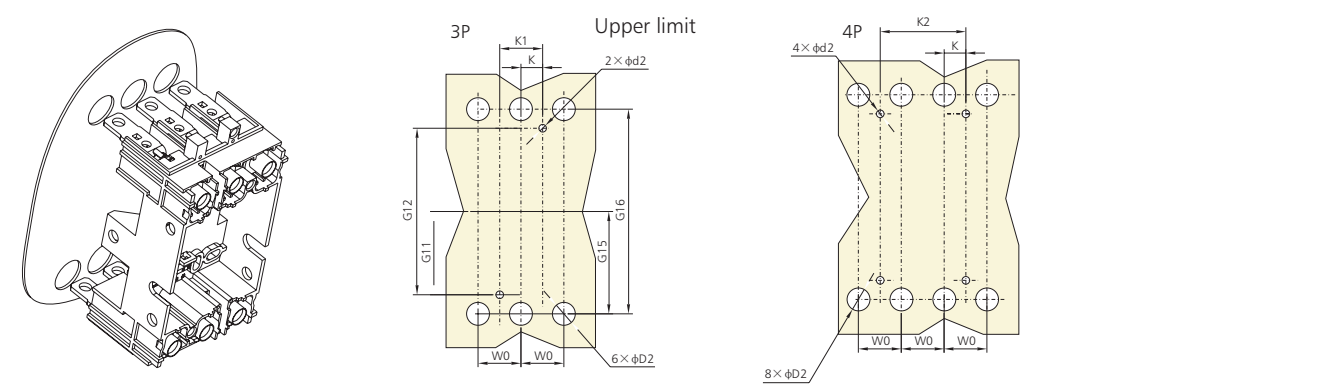

(mm)

Model	W0	W1	W2	L5	L6	H5	H6	H7	K	K1	K2	K3	K4	K5	K6	K7
NM8-125	30	90	120	90	180	24	40	67	15	30	60	47	94	124	30	60
NM8S-125/NM8-250/NM8S-250	35	105	140	102.5	205	27	45	75	17.5	35	70	54.5	109	144	35	70
NM8-400, 630/NM8S-400, 630	45	140	185	157.5	315	27	45	45	22.5	45	90	71.5	143	188	45	90

Model	K8	G5	G6	G7	G8	G9	G10	G11	G12	G13	G14	G15	G16	d2	D2	U
NM8-125	90	77	154	85.2	170.4	32.5	65	68	136	54.5	109	70.5	141	6	20	≤ 32
NM8S-125/NM8-250/NM8S-250	105	87	174	95	190	37.5	75	77.5	155	61	122	79	158	6	25	≤ 32
NM8-400, 630/NM8S-400, 630	140	137	274	150	300	75	150	125	250	100	200	126	252	6	33	≤ 32

8.6.4 Flush type (for fixed or plug-in type)

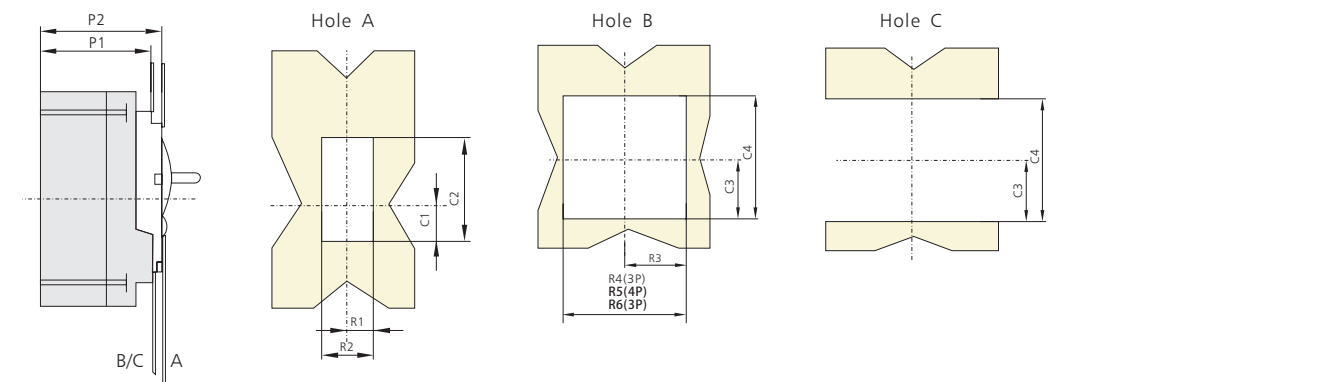

(mm)

Model	P1	P2	R1	R2	R3	R4	R5	R6	C1	C2	C3	C4
NM8-125	73	80	13	26	46.5	93	123	65	26	68	50.5	101
NM8S-125/NM8-250/NM8S-250	83	90	14.5	29	54	108	143	73	33	78	56.5	113
NM8-400, 630/NM8S-400, 630	109	114	26.5	53	71.5	143	188	-	41.5	116	108	205

9. Accessories

9.1 Inner accessories

9.1.1 Shunt release

$U_s = 70 \sim 110\%U_n$, circuit breaker reliably operates
Long-time electrification is prohibited
Time of response: pulsive type $\geq 20\text{ms}$, $\leq 60\text{ms}$

9.1.2 Under-voltage release

$U_s = 35 \sim 70\%U_n$, circuit breaker reliably breaks
 $U_s \geq 85\%U_n$, circuit breaker reliably closes
 $U_s < 35\%U_n$, prevent circuit breaker from making
Note: With under-voltage release, $U_s \geq 85\%U_n$, circuit breaker normally makes and breaks

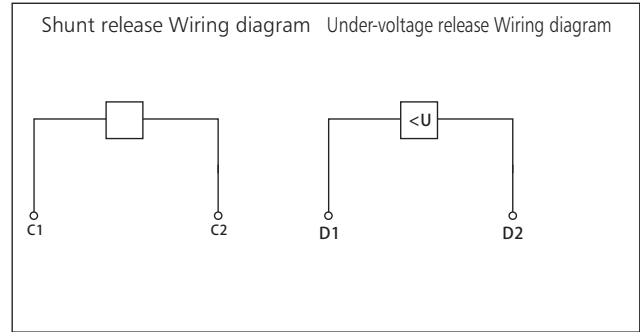

9.1.3 Auxiliary contact

Function: Indication of contacting status

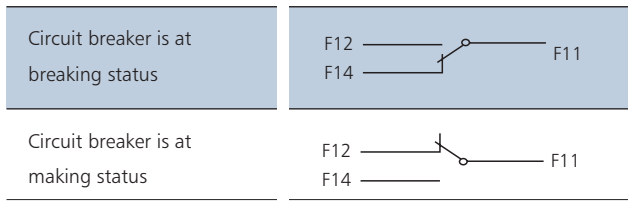

Wiring diagram

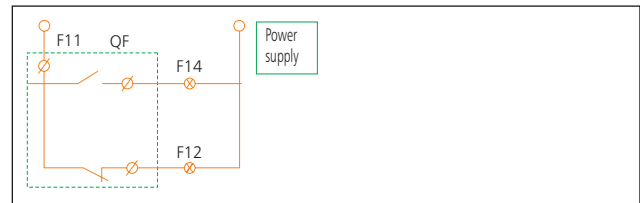

9.1.4 Alarm contact

Function: indication of reason for circuit breaker releasing;
* Over-load
* Short-circuit
* Grounding fault
* Operation of under-voltage releasing or free tripping
When circuit breaker normally makes and breaks, alarm contact not operates.
After free tripping (or tripping due to failure), alarm contact operates and after the circuit breaker again normally operates, alarm contact recovers original status.

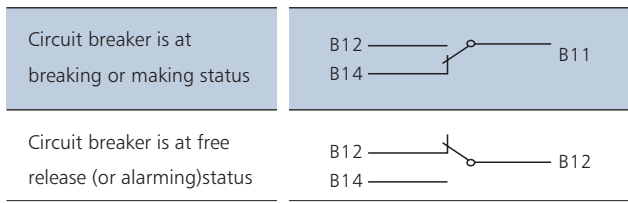

Wiring diagram

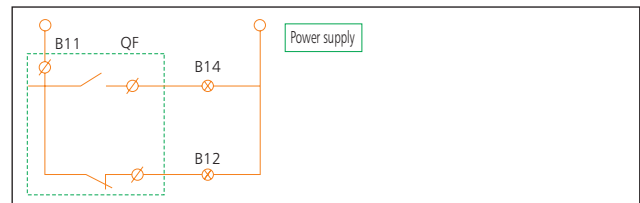

Accessory	Code	Mounting and wiring mode		
		NM8-125, 250 NM8S-125, 250	NM8-400, 630 NM8S-400, 630	NM8-800, 1250 NM8S-800, 1250,1600
		3P, 4P	3P, 4P	3P, 4P
No accessory				
Alarm contact	AL			
Shunt release	SM: AC220V, SQ: AC380V SB: DC24V			
Auxiliary contact	AX			
Under-voltage release	UM: AC220V UQ: AC380V			
Shunt release Auxiliary contact	SM: AC220V, SQ: AC380V, SB: DC24V AX			
Two groups of auxiliary contact	AX, AX			
Auxiliary contact Under-voltage release	AX UM: AC220V, UQ: AC380V			
Shunt release Alarm contact	SM: AC220V, SQ: AC380V, SB: DC24V AL			
Auxiliary contact Alarm contact	AX AL			
Under-voltage release Alarm contact	AL UM: AC220V, UQ: AC380V			
Shunt release Auxiliary contact, alarm	SM: AC220V, SQ: AC380V, SB: DC24V AX, AL			
Two groups of auxiliary contact	AX, AX AL			
Alarm contact Auxiliary contact, alarm contact Under-voltage release	AX, AL (UM: AC220V, UQ: AC380V)			

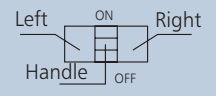

■-Shunt release ▲-Under-voltage release ○-Auxiliary contact ●-Alarm contact

Note: 1: For NM8-125, 250, 400, 630, NM8S-125, 250, 400, 630, under-voltage and shunt release couldn't be simultaneously equipped on one breaker.

2: For NM8-800, 1250, NM8S-800, 1250, 1600, at most three auxiliary contacts could be equipped, under-voltage and shunt release could be simultaneously equipped on one breaker, in addition, their positions could be exchanged.

9.2 External accessories

9.2.1 Economic extended rotary handle

Protection degree: IP30

Functions: Isolation function indication;

0(breaking), 1(making)and free tripping indication;

At "OFF" status, the breaker can be fitted with 1-3 padlocks with a diameter of 5-8mm(by customer), This prevents the door of switchgear being opened unwantedly.

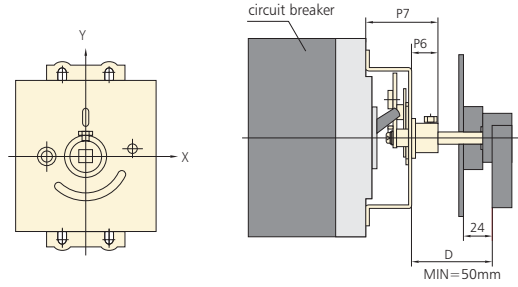

(mm)

Dimension	NM8-125	NM8S-125, NM8-250, NM8S-250	NM8-400, NM8S-400	NM8-630, NM8S-630	NM8(S)-800	NM8(S)-1250,1600
P6	14	14	20	20	21	21
P7	56	56	60	60	103	103



Handle mounting (mm)

NM8(S)-125,250,400,630

NM8(S)-800,1250,1600

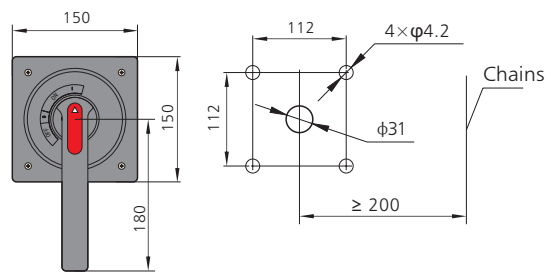
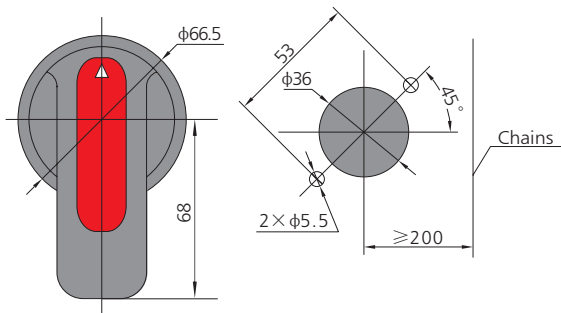

9.2.2 Direct rotary handle

Protection degree: IP40

Functions:

Reliable insulation;

Isolation function indication;

0(breaking), 1(making) and free tripping indication;

Realize free tripping of circuit breaker;

At "OFF" status, the breaker can be fitted with 1-3

padlocks with a diameter of

5~8mm (by customer).



Direct rotary handle

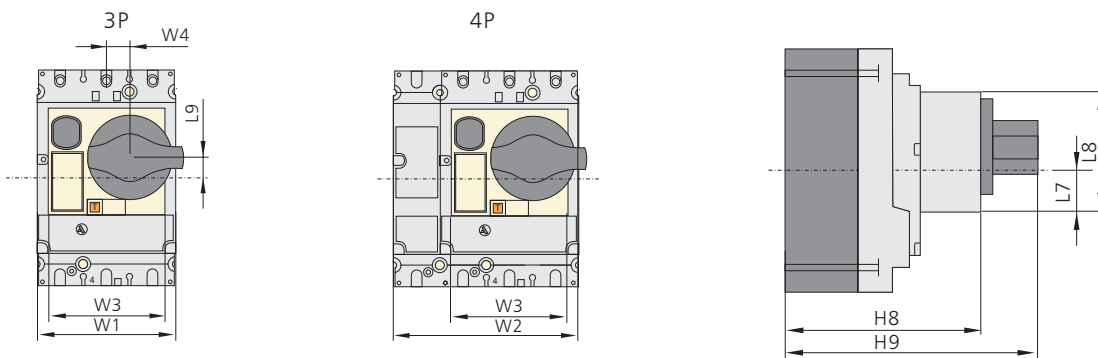

9.2.3 Extended rotary handle

Protection degree: IP55

Functions:

Reliable insulation;

Isolation function indication;

0(breaking), 1(making) and free tripping indication;

When the door is open, the release can be set

and the breaker will not make;

At "OFF" status, the breaker can be fitted with 1~3 padlocks with a diameter of 5~8mm (by customer).

Then door of the switchgear can be opened.



Front boring(fixed or plug-in circuit breaker)(mm)

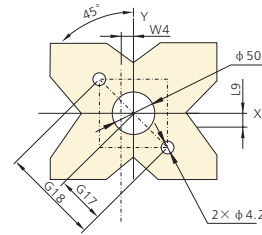
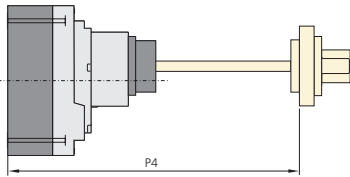

(mm)

Model	W1	W2	W3	W4	L7	L8	L9	H8	H9	P3	P4	R6	R7	C5	C6	G17	G18
NM8-125	30	90	76	15.25	37	70	13.3	115	163	80	≥175 ≤600	38	78	38	72	37	74
NM8S-125																	
NM8-250	35	105	93.5	9.25	39	77.5	9	126	174	90	≥175 ≤600	46.5	96	40.5	76	37	74
NM8S-250																	
NM8-400	45	140	122	5	69	121.5	24.5	152	200	115	≥175 ≤600	61	124	70.5	124	37	74
NM8S-400																	
NM8-630	45	140	122	5	69	121.5	24.5	152	200	115	≥175 ≤600	61	124	70.5	124	37	74
NM8S-630																	

9.2.4 Motor-driven mechanism

Protection degree: IP40

Functions:

Reliable insulation;

Isolation function indication;

0(breaking), 1(making) and free tripping indication;

Free releasing of circuit breaker;

Making and breaking the breaker manually or automatically

Manual operation

Turn "manual/auto" switch to "auto" position and then turn the handle to make and break the breaker.

Automatic operation:

Turn "manual/auto" switch to "manual" position and then push the button to make and break the breaker remotely.

The make/break operation is carried out via pulse or self-retaining type signal control.

Operational range: 85%Un~110%Un.



NM8 circuit breaker	Rated control voltage	Electrical life	Operational current	Power consumption
NM8-125	100-240V AC	10,000 operations	≤0.5 A	14VA
	100-220V DC			14W
	24V DC			14W
NM8S-125	100-240V AC	10,000 operations	≤0.5 A	14VA
	100-220V DC			14W
	24V DC			14W
NM8-400	230V AC	5,000 operations	≤2 A	35VA
	110V AC			35VA
	220V DC			35W
NM8S-400	110V AC	5,000 operations	≤2 A	35VA
	220V DC			35W
	24V DC			35W
NM8-800 NM8S-800 NM8-1250 NM8S-1250, 1600	230V/400V AC	3,000 operations	≤7.5 A	200W

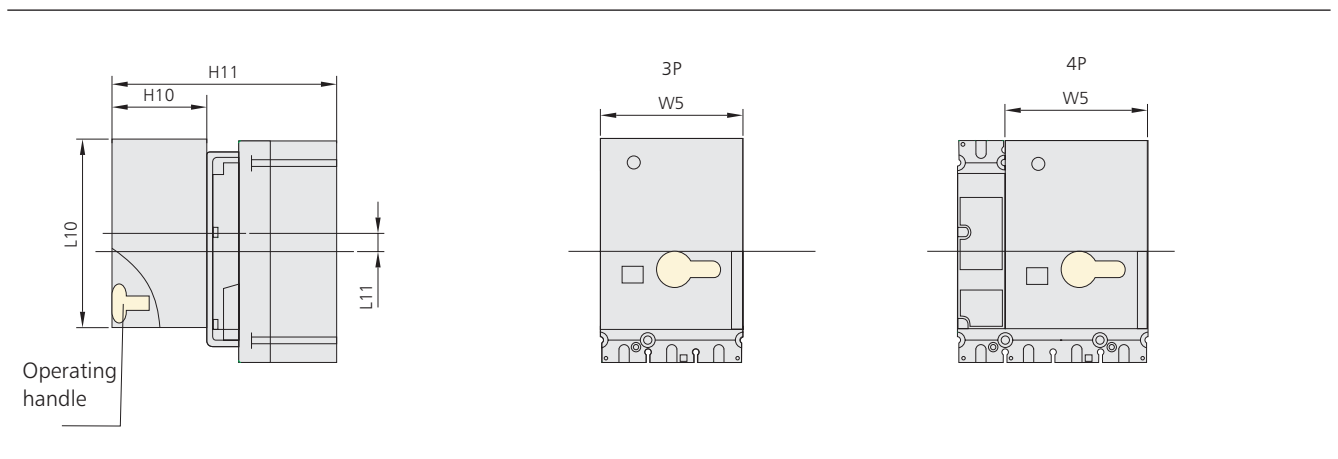

Front boring(fixed or plug-in circuit breaker)

Wiring diagram

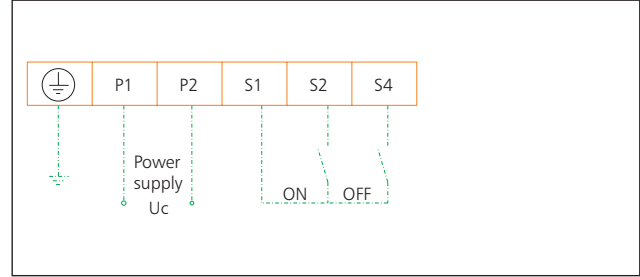
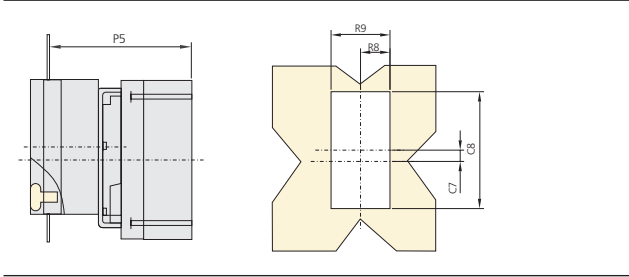

(mm)

Model	W5	H10	H11	L10	L11	R8	R9	P5	C7	C8
NM8-125	90	77	164	117	17.3	46.5	93	144	17.3	120
NM8S-125, NM8-250, NM8S-250	90	77	175	117	14.5	46.5	93	155	14.5	120
NM8-400, NM8S-400	107	115	250	174	19	64	128	225	19	177
NM8-630, NM8S-630	107	115	250	174	19	64	128	225	19	177
NM8-800, NM8S-800	-	-	-	-	-	-	-	-	-	-
NM8-1250, NM8S-1250, 1600	-	-	-	-	-	-	-	-	-	-

9.3 Locking system

Locking the breaker at status of making or breaking.
The system can be fitted with 1~3 padlocks with a diameter of 5~8mm (by customer).

9.4 Terminal cover

Protection degree: IP40
Protect from being contacted with main circuit.
Selection of terminal cover:
Fixed breaker (front connection): Long terminal cover;
Fixed breaker (rear connection): Short terminal cover;
Plug-in breaker: short terminal cover;
When voltage is $\geq 500V$, terminal cover selected for definite connection mode

Locking system

Long terminal cover

Short terminal cover

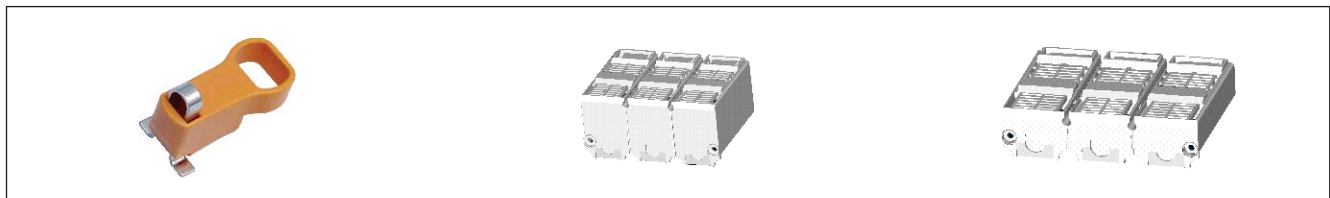

10. Complementary technical information

10.1 Isolation function

Isolation functions of all the circuit breakers as per IEC60947/EN60947-2; Isolating position of contactors is at 0 (OFF) status. The operating handle will correctly indicate the status of 0(OFF), only if the contactor breaks.

Padlocks could be mounted after the contacts breaks;
Operation of isolation functions will realize following points:

- Contacts operation correctly indicates:
 - operating reliability of interior mechanism;
- No residual current;
- Higher impulse withstands voltage for terminals at the power supply side and on-load side.

10.2 Current-limiting

10.2.1 Current-limiting capacity

The current-limiting capacity of a circuit breaker is its aptitude to limit short-circuits current. By occurring of short-circuit, the breaker is able to limit I^2t in time so as to protect circuits and switchgear at downstream.

The exceptional limiting capacity of NM8 series is due to the rotating double-break technique, which is characterized by very rapid natural repulsion of contacts and the appearance of two arc voltages in series with a very steep wave front.

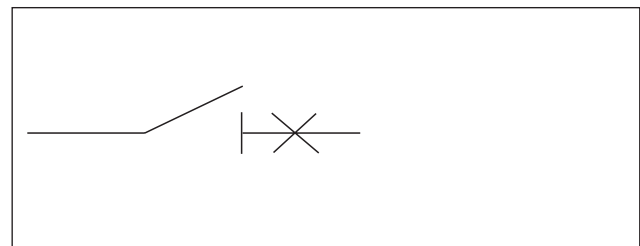

- a. Exceptional current-limiting capacity is able to greatly reduce power caused by fault current so as to enhance breaking capacity of breaker to $I_{cs}=100\%I_{cu}$;
- b. The capacity has greatly released damages, which short-circuit current lay to apparatus;
- c. The capacity has greatly lowered temperature-rise so as to lengthen service life of the cable;
- d. The capacity has greatly reduced power so as to lessen distortion of contacts and bus bar;
- e. The capacity has greatly decreased interruptions to apparatus nearby.

10.2.2 Current-limiting curves

The current-limiting capacity of a circuit breaker is expressed by two curves which are the prospective current and the actual short-circuit current.

Thermal stress (A^2S), i.e. the energy dissipated by the short-circuit current in a conductor with a resistance of 1Ω .

The table below indicates the maximum permissible thermal stresses for cables depending on their insulation, conductor (Cu or Al) and cross section area (CSA).

CSA values are given in mm^2 and thermal stresses in A^2S .

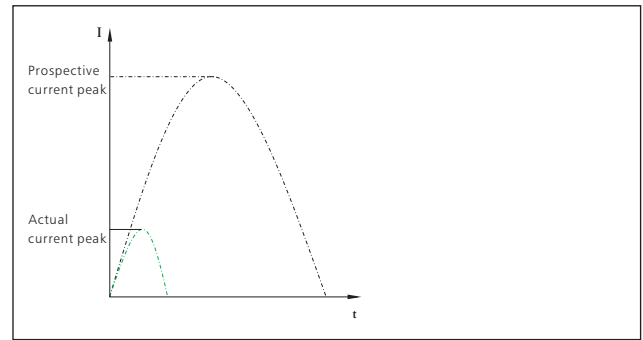

CSA(mm ²)		1.5	2.5	4	6	10	16	25	35
PVC	Cu K=115	2.97×10^4	8.26×10^4	2.12×10^5	4.76×10^5	1.32×10^6	3.40×10^6	8.26×10^6	1.62×10^7
	Al K=76	1.30×10^4	3.61×10^4	9.26×10^4	2.08×10^5	5.78×10^5	1.48×10^6	3.16×10^6	7.08×10^6
Butyl	Cu K=131	3.86×10^4	1.07×10^5	2.75×10^5	6.18×10^5	1.72×10^6	4.39×10^6	1.07×10^7	2.10×10^7
	Al K=87	1.70×10^4	4.73×10^4	1.21×10^5	2.72×10^5	7.57×10^5	1.94×10^6	4.73×10^6	9.27×10^6
EPR	Cu K=143	4.60×10^4	1.28×10^5	3.27×10^5	7.36×10^5	2.04×10^6	5.23×10^6	1.28×10^7	2.51×10^7
	Al K=94	1.99×10^4	5.52×10^4	1.41×10^5	3.18×10^5	8.84×10^5	2.26×10^6	5.52×10^6	1.08×10^7

CSA(mm ²)		50	70	95	120	150	185	240
PVC	Cu K=115	3.31×10^4	6.48×10^4	1.19×10^5	1.90×10^5	2.98×10^6	4.53×10^6	7.62×10^6
	Al K=76	1.44×10^4	2.83×10^4	5.21×10^4	8.32×10^4	1.30×10^6	1.98×10^6	3.33×10^6
Butyl	Cu K=131	4.29×10^4	8.41×10^4	1.55×10^5	2.47×10^5	3.86×10^6	5.87×10^6	9.88×10^6
	Al K=87	1.89×10^4	3.71×10^4	6.83×10^4	1.09×10^5	1.70×10^6	2.59×10^6	4.36×10^6
EPR	Cu K=143	5.11×10^4	1.00×10^5	1.85×10^5	2.94×10^5	4.60×10^6	7.00×10^6	1.18×10^7
	Al K=94	2.21×10^4	4.33×10^4	7.97×10^4	1.27×10^5	1.99×10^6	3.02×10^6	5.09×10^6

K is quoted from GB-50054 code for design of low voltage electrical installations.

Example:

a. What is the actual current when a prospective short-circuit current of 125kA rms (peak value=275kA) comes through the current-limiting operation circuit breaker at upstream of NM8-125R

Answer: the peak value=23kA; (for details, refer to current-limiting curves)

b. Is a Cu/PVC cable with a CSA of 10mm² adequately protected by a NM8-125S circuit breaker

Answer: the table above indicates that the permissible thermal stress is $1.32 \times 10^6 A^2S$

at the point where a NM8-125S ($I_{cu}=50kA$) is installed,

and the short-circuit current is limited within the range of $1.32 \times 10^6 A^2S$, therefore the cable could be protected.

$I^2 t$ Curve

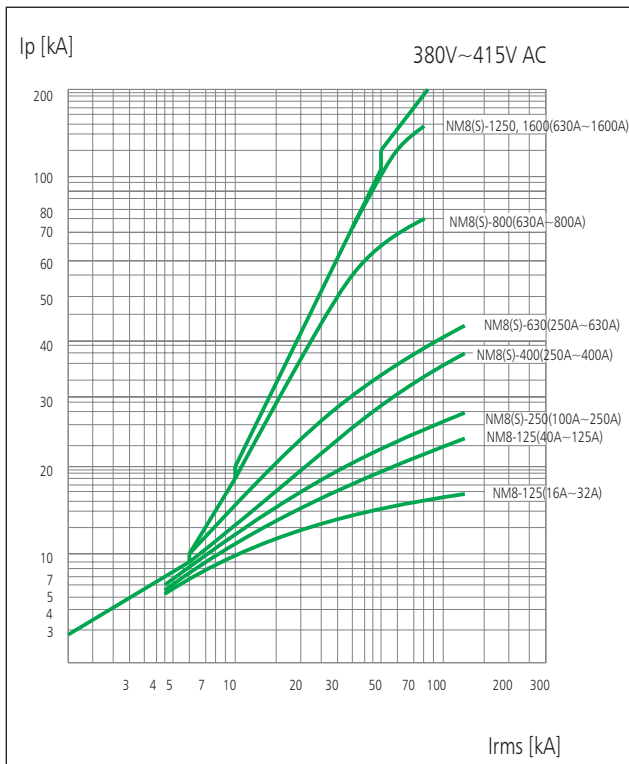

A^2s curve

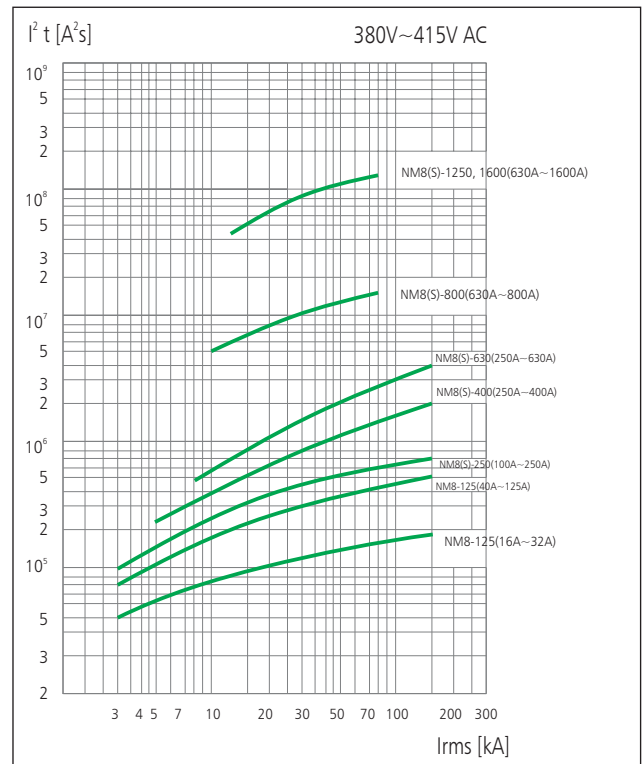

I² t Curve

A²s curve

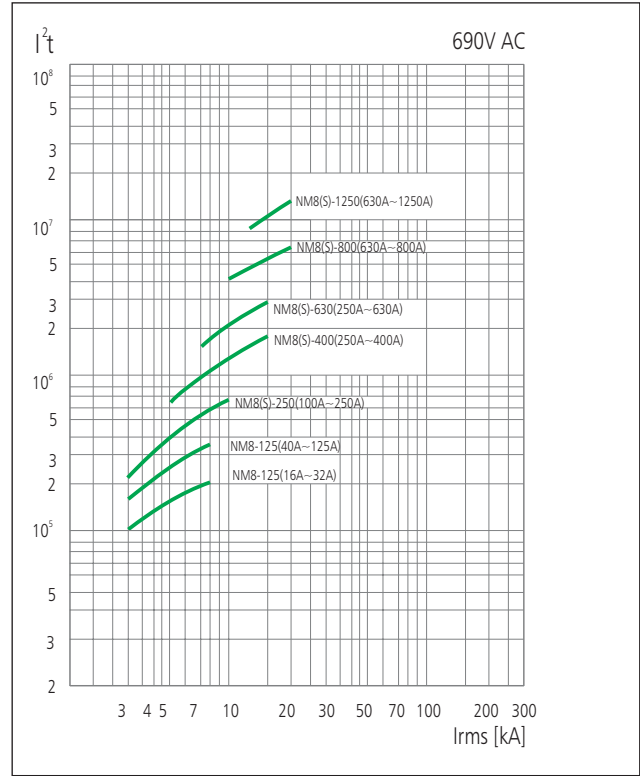
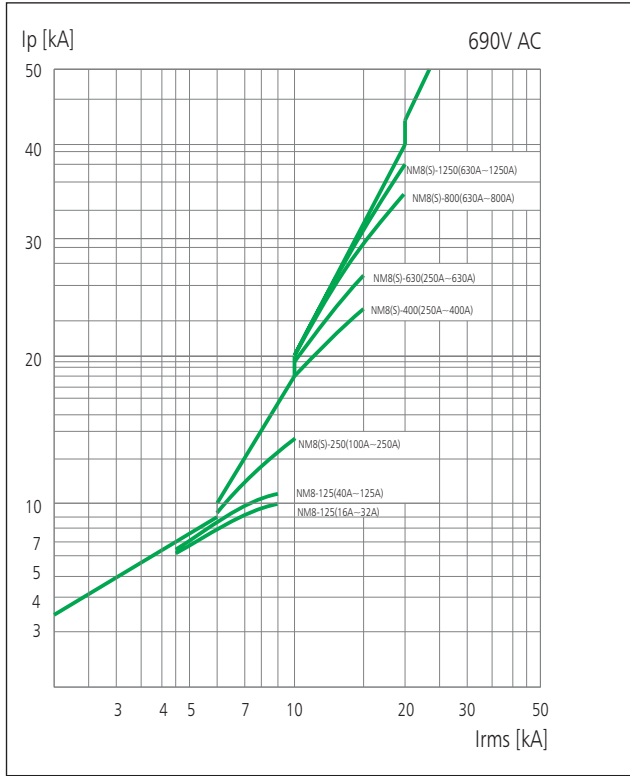

10.3 Power loss per pole

Resistance/ power loss mΩ/W	NM8-125	NM8S-125	NM8-250	NM8S-250	NM8-400	NM8S-400	NM8-630	NM8S-630	NM8-800	NM8S-800	NM8-1250	NM8S-1250,1600
16	7.1/1.8											
20	6.2/2.5											
25	4.8/3											
32	3.7/3.8											
40	2.6/4.2	0.85/1.4										
50	2.7/6.8	0.7/1.8										
63	1.7/6.7	0.7/2.8										
80	1.3/8.3	0.7/4.5										
100	0.85/8.5	0.5/5	1.0/10	0.5/5								
125	0.71/11.1	0.5/7.8	1.0/15.6	0.5/7.8								
160			0.55/14	0.36/9.2								
180			0.55/17.8	0.36/11.7								
200			0.55/22	0.36/14.4								
225			0.55/27.8	0.28/14.2								
250			0.55/34.4	0.28/17.5	0.3/18.8	0.15/9.4	0.3/18.8	0.13/8.1				
315					0.28/27.8	0.15/14.9	0.28/27.8	0.13/12.9				
350					0.28/34.3	0.15/18.4	0.28/34.3	0.13/15.9				
400					0.24/38.4	0.15/24	0.24/38.4	0.13/20.8				
500							0.2/50	0.13/32.5				
630								0.13/51.6	0.04/15.9	0.04/15.9	0.04/15.9	0.04/15.9
700									0.04/19.6	0.04/19.6	0.04/19.6	0.04/19.6
800									0.04/25.6	0.04/25.6	0.04/25.6	0.04/25.6
1000											0.04/40	0.04/40
1250, 1600											0.04/62.5	0.04/62.5

10.4 Influences which altitude lay to tripping characteristics

To tripping characteristics of circuit breaker, it is no obvious influence, when the altitude does not exceed 2000m. Once the altitude exceeds the level of 2000m, factors of dielectric stress lowering and cooled air should be taken into consideration.

Altitude (m)	2000	3000	4000	5000
Dielectric stress (V)	3000	2500	2100	1800
Max. operational voltage (V)	690	550	480	420
Ratings at 40°C (A)	1In	0.96In	0.93In	0.9In

10.5 Cascading

Definition of Cascading

Current-limiting technique has been adopted for cascading to install downstream circuit breaker with lower breaking capacity (cheaper circuit breakers) at the given point of circuit, and upstream NM8(S) circuit breaker operates to limit short-circuit current. Under the operation of cascading network, circuit breaker with lower breaking capacity compared with prospective short-circuit current at the given point could operate under normal short-circuit status. As the short-circuit current will be limited by upstream circuit breaker with current-limiting operation, cascading network is applicable to all the power distribution apparatus protection at downstream.

In addition, cascading operation is not restricted to operation of two switches in serial, but is applicable in various electric networks, as well.

Application of cascading

Through the application of cascading, connected apparatuses could be installed in different switchgears to realize normal operation. Therefore, cascading, in common, refers to various combination of circuit breakers installed at the given point of which the breaking capacity is lower than prospective short-circuit current. And breaking capacity of upstream circuit breakers should be equal to or higher than prospective short-circuit current at the installed point to protect apparatus at downstream. Cascading application is in conformity with IEC60947-2 standards.

Cascading (220/230/240V)

Upstream: NM8-125~1250

Downstream: DZ47, eB, UB, DZ158, DZ267, NB1, NBH8, NM8 (S)-125~1250

Upstream Breaking capacity (kA rms) →	NM8-125S	NM8-125H	NM8-125R	NM8-250S	NM8-250H	NM8-250R	NM8-400S	
	85	100	150	85	100	150	85	
Downstream ↓	Breaking capacity (kA rms)							
DZ267	30	80	80	30	40	40		
DZ47, eB, UB	30	80	80	30	40	40		
NBH8	30	80	80	30	40	40		
NB1(Icn=6000A)	40	100	100	40	50	50		
NB1-63(Icn=10000A)	50	100	100	50	65	65		
DZ158-100	50	100	100	50	65	65	50	
NM8-125S		100	150		100	150		
NM8-125H			150			150		
NM8-250S					100	150		
NM8-250H						150		
NM8-400S								
NM8-400H								
NM8-630S								
NM8-630H								
NM8-800S								
NM8-800H								
NM8-1250S								
NM8-1250H								
NM8S-125S		100	150		100	150		
NM8S-125H			150			150		
NM8S-250S					100	150		
NM8S-250H						150		
NM8S-400S								
NM8S-400H								
NM8S-630S								
NM8S-630H								
NM8S-800S								
NM8S-800H								
NM8S-1250S								
NM8S-1250H								

NM8-400H 100	NM8-400R 150	NM8-630S 85	NM8-630H 100	NM8-630R 150	NM8-800S 65	NM8-800H 100	NM8-1250S 65	NM8-1250H 100
65	65							
100	150		100	150		100		100
	150			150				
100	150		100	150		100		100
	150			150				
100	150		100	150		100		100
	150			150				
			100	150		100		100
				150				
						100		100
							100	100
100	150		100	150		100		100
	150			150				
100	150		100	150		100		100
	150			150				
100	150		100	150		100		100
	150			150				
			100	150		100		100
				150				
						100		100
						100		100

Upstream: NM8S-125~1600

Downstream: DZ267, DZ47, eB, UB, NBH8, NB1, DZ158, NM8(S)-125~1600

Upstream Breaking capacity (kA rms) →	NM8S-125S 85	NM8S-125H 100	NM8S-250S 85	NM8S-250H 100	NM8S-400S 85	NM8S-400H 100	NM8S-400R 150	
	Downstream ↓ Breaking capacity (kA rms)							
DZ267	30	80	30	40				
DZ47, eB, UB	30	80	30	40				
NBH8	30	80	30	40				
NB1(Icn=6000A)	40	100	40	50				
NB1(Icn=10000A)	50	100	50	65				
DZ158-100	50	100	50	65	50	65	65	
NM8-125S		100		100		100	150	
NM8-125H							150	
NM8-250S				100		100	150	
NM8-250H							150	
NM8-400S						100	150	
NM8-400H							150	
NM8-630S								
NM8-630H								
NM8-800S								
NM8-800H								
NM8-1250S								
NM8-1250H								
NM8S-125S		100		100		100	150	
NM8S-125H							150	
NM8S-250S				100		100	150	
NM8S-250H							150	
NM8S-400S						100	150	
NM8S-400H							150	
NM8S-630S								
NM8S-630H								
NM8S-800S								
NM8S-800H								
NM8S-1250S								
NM8S-1250H								
NM8S-1600H								

Cascading (380/400/415V)

Upstream: NM8-125~1250;

Downstream: DZ47,eB, UB, DZ158, DZ267, NB1, NBH8, NM8(S)-125~1250

Upstream Breaking capacity (kA rms) →	NM8-125S 50	NM8-125H 100	NM8-125R 150	NM8-250S 50	NM8-250H 100	NM8-250R 150	NM8-400S 70
	Downstream ↓ Breaking capacity (kA rms)						
DZ47, eB, UB	15	20	20	15	20	20	
NB1(Icn=6000A)	25	30	30	25	30	30	
NB1-63(Icn=10000A)	25	40	40	25	40	40	
DZ158-100	25	40	40	25	40	40	25
NM8-125S		100	150		100	150	70
NM8-125H			150			150	
NM8-250S					100	150	70
NM8-250H						150	
NM8-400S							
NM8-400H							
NM8-630S							
NM8-630H							
NM8-800S							
NM8-800H							
NM8-1250S							
NM8-1250H							
NM8S-125S		100	150		100	150	70
NM8S-125H			150			150	
NM8S-250S					100	150	70
NM8S-250H						150	
NM8S-400S							
NM8S-400H							
NM8S-630S							
NM8S-630H							
NM8S-800S							
NM8S-800H							
NM8S-1250S							
NM8S-1250H							

NM8-400H 100	NM8-400R 150	NM8-630S 70	NM8-630H 100	NM8-630R 150	NM8-800S 50	NM8-800H 70	NM8-1250S 50	NM8-1250H 70
40	40							
100	150							
	150	70	100	150		70		70
100	150			150				
	150	70	100	150		70		70
100	150			150				
	150		100	150		70		70
				150				
			100	150		70		70
				150				
						70		70
						70		70
100	150							
	150	70	100	150		70		70
100	150			150				
	150	70	100	150		70		70
100	150			150				
	150		100	150		70		70
				150				
			100	150		70		70
				150				
						70		70
						70		70

Upstream: NM8S-125~1250

Downstream: DZ267, DZ47, eB, UB, NBH8, NB1, DZ158, NM8 (S) -125~1250

Upstream Breaking capacity (kA rms)	Breaking capacity (kA rms)						
	NM8S-125S 50	NM8S-125H 100	NM8S-250S 50	NM8S-250H 100	NM8S-400S 70	NM8S-400H 100	NM8S-400R 150
Downstream							
Dz47, eB, UB	15	20	15	20			
NB1(Icn=6000A)	25	30	25	30			
NB1-63(Icn=10000A)	25	40	25	40			
DZ158	25	40	25	40	25	40	40
NM8-125S		100		100		100	150
NM8-125H				100		100	150
NM8-250S				100		100	150
NM8-250H						100	150
NM8-400S						100	150
NM8-400H							150
NM8-630S							
NM8-630H							
NM8-800S							
NM8-800H							
NM8-1250S							
NM8-1250H							
NM8S-125S		100		100		100	150
NM8S-125H				100		100	150
NM8S-250S				100		100	150
NM8S-250H						100	150
NM8S-400S						100	150
NM8S-400H							150
NM8S-630S							
NM8S-630H							
NM8S-800S							
NM8S-800H							
NM8S-1250S							
NM8S-1250H							
NM8S-1600H							

	NM8S-630S 70	NM8S-630H 100	NM8S-630R 150	NM8S-800S 50	NM8S-800H 70	NM8S-1250S 50	NM8S-1250H 70	NM8S-1600H 70
		100	150		70		70	70
		100	150		70		70	70
		100	150		70		70	70
		100	150		70		70	70
		100	150		70		70	70
		100	150		70		70	70
		100	150		70		70	70
		100	150		70		70	70
			150		70		70	70
					70		70	70
					70		70	70
					70		70	70
					70		70	70
		100	150		70		70	70
		100	150		70		70	70
		100	150		70		70	70
		100	150		70		70	70
		100	150		70		70	70
		100	150		70		70	70
		100	150		70		70	70
			150		70		70	70
					70		70	70
					70		70	70
					70		70	70
					70		70	70
					70		70	70
					70		70	70

10.6 Protection discrimination(selectivity)

Protection discrimination is a must factor in low-voltage power distribution design so as to ensure reliability and continuity for users' electricity utilization.

Whenever there is fault occurring in the electric network, the upstream breaker where the fault is occurring breaks.

Protection discrimination could be clarified into 3 kinds: Total protection discrimination, partial protection discrimination and no protection discrimination(refer to fig aside):

Total protection discrimination: For all kinds of current where the faults occurred, including the overload current and nonresistance current, breaker D2 breaks and breaker D1 keeps making status.

Partial protection discrimination: For a much lower current compared with where the fault occurred (the limit value of protection discrimination), breaker D2 breaks and breaker D1 keeps making status (total protection discrimination).

When the fault current is lower than limit value of protection discrimination, the upstream and downstream breakers are applicable to protection discrimination; when the fault current exceeds limit value of protection discrimination, the upstream and downstream breakers are not applicable to protection discrimination (no protection discrimination). And both of the breakers of D1 and D2 break.

Upstream: NM8-125~1250

Downstream: DZ267, DZ47, eB, UB, NBH8, NB1, DZ158

		NM8-125 S/H/R										NM8-250 S/H/R			
		16	20	25	32	40	50	63	80	100	125	100	160	200	250
DZ267 C Curves	≤10	0.19	0.25	0.3	0.4	0.5	0.5	0.5	0.63	0.8	1.0	T	T	T	T
	16			0.3	0.4	0.5	0.5	0.5	0.63	0.8	1.0	T	T	T	T
	20					0.5	0.5	0.5	0.63	0.8	1.0	T	T	T	T
	25						0.5	0.5	0.63	0.8	1.0	T	T	T	T
	32							0.5	0.63	0.8	1.0	T	T	T	T
DZ47, eB, UB C Curves	≤10	0.19	0.25	0.3	0.4	0.5	0.5	0.5	0.63	0.8	1.0	T	T	T	T
	16			0.3	0.4	0.5	0.5	0.5	0.63	0.8	1.0	T	T	T	T
	20					0.5	0.5	0.5	0.63	0.8	1.0	T	T	T	T
	25						0.5	0.5	0.63	0.8	1.0	T	T	T	T
	32							0.5	0.63	0.8	1.0	T	T	T	T
	40								0.63	0.8	1.0	T	T	T	T
	50									0.8	1.0	T	T	T	T
60										1.0	T	T	T	T	
NBH8 B C Curves	≤10	0.19	0.25	0.3	0.4	0.5	0.5	0.5	0.63	0.8	1.0	T	T	T	T
	16			0.3	0.4	0.5	0.5	0.5	0.63	0.8	1.0	T	T	T	T
	20					0.5	0.5	0.5	0.63	0.8	1.0	T	T	T	T
	25						0.5	0.5	0.63	0.8	1.0	T	T	T	T
	32							0.5	0.63	0.8	1.0	T	T	T	T
NB1 B C D Curves	≤10	0.19	0.25	0.3	0.4	0.5	0.5	0.5	0.63	0.8	1.0	T	T	T	T
	16			0.3	0.4	0.5	0.5	0.5	0.63	0.8	1.0	T	T	T	T
	20					0.5	0.5	0.5	0.63	0.8	1.0	T	T	T	T
	25						0.5	0.5	0.63	0.8	1.0	T	T	T	T
	32							0.5	0.63	0.8	1.0	T	T	T	T
	40								0.63	0.8	1.0	T	T	T	T
	50									0.8	1.0	T	T	T	T
DZ158	63									0.8	1.0	T	T	T	T
	80										1.0	T	T	T	T
	100											T	T	T	T

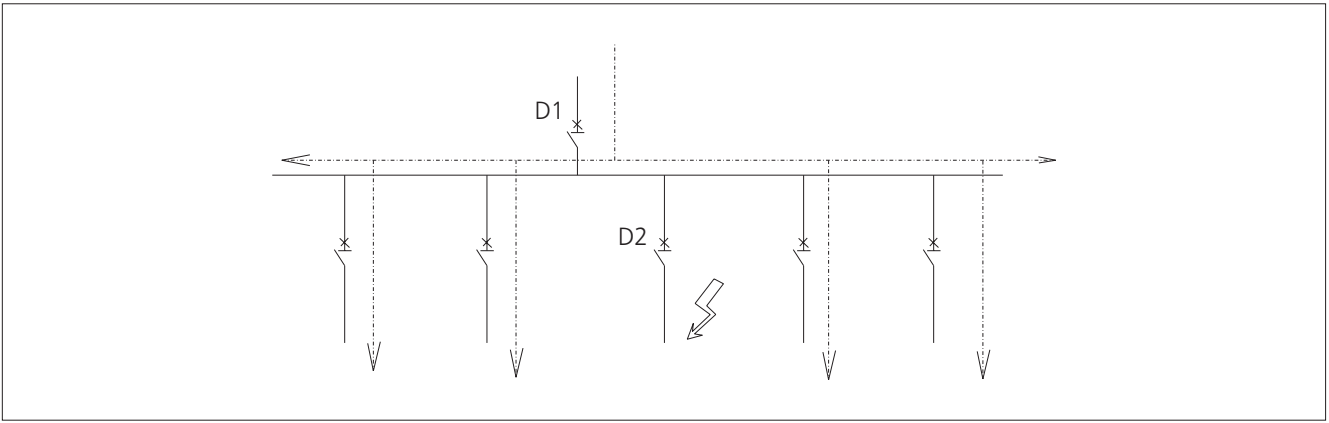

NM8-400 S/H/R				NM8-630 S/H/R					NM8-800 S/H			NM8-1250 S/H				
250	315	350	400	250	315	350	400	500	630	700	800	630	700	800	1000	1250
T	T	T	T	T	T	T	T	T	T	T	T	T	T	T	T	T
T	T	T	T	T	T	T	T	T	T	T	T	T	T	T	T	T
T	T	T	T	T	T	T	T	T	T	T	T	T	T	T	T	T
T	T	T	T	T	T	T	T	T	T	T	T	T	T	T	T	T
T	T	T	T	T	T	T	T	T	T	T	T	T	T	T	T	T
T	T	T	T	T	T	T	T	T	T	T	T	T	T	T	T	T
T	T	T	T	T	T	T	T	T	T	T	T	T	T	T	T	T
T	T	T	T	T	T	T	T	T	T	T	T	T	T	T	T	T
T	T	T	T	T	T	T	T	T	T	T	T	T	T	T	T	T
T	T	T	T	T	T	T	T	T	T	T	T	T	T	T	T	T
T	T	T	T	T	T	T	T	T	T	T	T	T	T	T	T	T
T	T	T	T	T	T	T	T	T	T	T	T	T	T	T	T	T
T	T	T	T	T	T	T	T	T	T	T	T	T	T	T	T	T
T	T	T	T	T	T	T	T	T	T	T	T	T	T	T	T	T
T	T	T	T	T	T	T	T	T	T	T	T	T	T	T	T	T
T	T	T	T	T	T	T	T	T	T	T	T	T	T	T	T	T
T	T	T	T	T	T	T	T	T	T	T	T	T	T	T	T	T
T	T	T	T	T	T	T	T	T	T	T	T	T	T	T	T	T
T	T	T	T	T	T	T	T	T	T	T	T	T	T	T	T	T
T	T	T	T	T	T	T	T	T	T	T	T	T	T	T	T	T
T	T	T	T	T	T	T	T	T	T	T	T	T	T	T	T	T

Upstream: NM8S-125~1250

Downstream: DZ267, DZ47, eB, UB, NBH8, NB1, DZ158

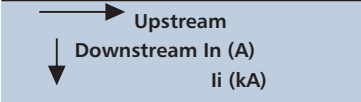
		NM8S-125 S/H			NM8S-250 S/H				NM8S-400 S/H/R			
		40	100	125	100	160	200	250	250	315	350	400
DZ267 C Curves	≤10	0.5	0.8	1.0	T	T	T	T	T	T	T	T
	16	0.5	0.8	1.0	T	T	T	T	T	T	T	T
	20	0.5	0.8	1.0	T	T	T	T	T	T	T	T
	25		0.8	1.0	T	T	T	T	T	T	T	T
	32		0.8	1.0	T	T	T	T	T	T	T	T
DZ47, eB, UB C Curves	≤10	0.5	0.8	1.0	T	T	T	T	T	T	T	T
	16	0.5	0.8	1.0	T	T	T	T	T	T	T	T
	20	0.5	0.8	1.0	T	T	T	T	T	T	T	T
	25		0.8	1.0	T	T	T	T	T	T	T	T
	32		0.8	1.0	T	T	T	T	T	T	T	T
	40		0.8	1.0	T	T	T	T	T	T	T	T
	50		0.8	1.0	T	T	T	T	T	T	T	T
NBH8 B C Curves	≤10	0.5	0.8	1.0	T	T	T	T	T	T	T	T
	16	0.5	0.8	1.0	T	T	T	T	T	T	T	T
	20	0.5	0.8	1.0	T	T	T	T	T	T	T	T
	25		0.8	1.0	T	T	T	T	T	T	T	T
	32		0.8	1.0	T	T	T	T	T	T	T	T
NB1 B C D Curves	≤10	0.5	0.8	1.0	T	T	T	T	T	T	T	T
	16	0.5	0.8	1.0	T	T	T	T	T	T	T	T
	20	0.5	0.8	1.0	T	T	T	T	T	T	T	T
	25		0.8	1.0	T	T	T	T	T	T	T	T
	32		0.8	1.0	T	T	T	T	T	T	T	T
	40		0.8	1.0	T	T	T	T	T	T	T	T
	50		0.8	1.0	T	T	T	T	T	T	T	T
DZ158	63		0.8	1.0	T	T	T	T	T	T	T	T
	80			1.0	T	T	T	T	T	T	T	T
	100					T	T	T	T	T	T	T
	63		0.8	1.0	T	T	T	T	T	T	T	T
	80			1.0	T	T	T	T	T	T	T	T
	100					T	T	T	T	T	T	T
	125					T	T	T	T	T	T	T

Upstream: NM8-125~1250
Downstream: NM8(S)-125~1250

Upstream Downstream In (A) Ii (kA)	NM8-125 S/H/R										NM8-250 S/H/R			
	16	20	25	32	40	50	63	80	100	125	100	160	200	
NM8-125 S	16			0.4	0.5	0.5	0.5	0.63	0.8	1.0	2.0	T	T	T
	20				0.5	0.5	0.5	0.63	0.8	1.0	2.0	T	T	T
	25					0.5	0.5	0.63	0.8	1.0	2.0	T	T	T
	32						0.5	0.63	0.8	1.0	2.0	T	T	T
	40							0.63	0.8	1.0	2.0	T	T	T
	50								0.8	1.0	2.0	T	T	T
	63									1.0	2.0	T	T	T
	80											1.25	T	T
	100											1.25	T	T
125													T	
NM8-125 H/R	16			0.4	0.5	0.5	0.5	0.63	0.8	1.0	2.0	T	T	T
	20				0.5	0.5	0.5	0.63	0.8	1.0	2.0	T	T	T
	25					0.5	0.5	0.63	0.8	1.0	2.0	T	T	T
	32						0.5	0.63	0.8	1.0	2.0	T	T	T
	40							0.63	0.8	1.0	2.0	3.6	3.6	3.6
	50								0.8	1.0	2.0	3.6	3.6	3.6
	63									1.0	2.0	3.6	3.6	3.6
	80											3.6	3.6	3.6
	100											3.6	3.6	3.6
125													3.6	
NM8S-125 S/H	40							0.63	0.8	1.0	1.25	T	T	T
	100											1.25	T	T
	125													2.5
NM8-250 S	100													3
	160													
	200													
	250													
NM8-250 H/R	100													3
	160													
	200													
	250													
NM8S-250 S/H	100											1.6	2	2.5
	160													2.5
	200													
	250													
NM8-400 S/H/R	250													
	315													
	350													
	400													
NM8S-400 S/H/R	250													
	315													
	350													
	400													
NM8-630 S/H/R	250													
	315													
	350													
	400													
500														

NM8-400 S/H/R				NM8-630 S/H/R					NM8-800 S/H			NM8-1250 S/H					
250	315	350	400	250	315	350	400	500	630	700	800	630	700	800	1000	1250	
T	T	T	T	T	T	T	T	T	T	T	T	T	T	T	T	T	
T	T	T	T	T	T	T	T	T	T	T	T	T	T	T	T	T	
T	T	T	T	T	T	T	T	T	T	T	T	T	T	T	T	T	
T	T	T	T	T	T	T	T	T	T	T	T	T	T	T	T	T	
T	T	T	T	T	T	T	T	T	T	T	T	T	T	T	T	T	
T	T	T	T	T	T	T	T	T	T	T	T	T	T	T	T	T	
T	T	T	T	T	T	T	T	T	T	T	T	T	T	T	T	T	
T	T	T	T	T	T	T	T	T	T	T	T	T	T	T	T	T	
T	T	T	T	T	T	T	T	T	T	T	T	T	T	T	T	T	
T	T	T	T	T	T	T	T	T	T	T	T	T	T	T	T	T	
T	T	T	T	T	T	T	T	T	50	50	50	50	50	50	50	T	T
T	T	T	T	T	T	T	T	T	50	50	50	50	50	50	50	T	T
T	T	T	T	T	T	T	T	T	50	50	50	50	50	50	50	T	T
T	T	T	T	T	T	T	T	T	50	50	50	50	50	50	50	T	T
T	T	T	T	T	T	T	T	T	50	50	50	50	50	50	50	T	T
T	T	T	T	T	T	T	T	T	50	50	50	50	50	50	50	T	T
T	T	T	T	T	T	T	T	T	50	50	50	50	50	50	50	T	T
T	T	T	T	T	T	T	T	T	50	50	50	50	50	50	50	T	T
T	T	T	T	T	T	T	T	T	50	50	50	50	50	50	50	T	T
T	T	T	T	T	T	T	T	T	50	50	50	50	50	50	50	T	T
T	T	T	T	T	T	T	T	T	50	50	50	50	50	50	50	T	T
T	T	T	T	T	T	T	T	T	50	50	50	50	50	50	50	T	T
T	T	T	T	T	T	T	T	T	50	50	50	50	50	50	50	T	T
T	T	T	T	T	T	T	T	T	50	50	50	50	50	50	50	T	T
T	T	T	T	T	T	T	T	T	50	50	50	50	50	50	50	T	T
T	T	T	T	T	T	T	T	T	50	50	50	50	50	50	50	T	T
T	T	T	T	T	T	T	T	T	50	50	50	50	50	50	50	T	T
5	T	T	T	3	T	T	T	T	T	T	T	T	T	T	T	T	T
	5	T	T		5	T	T	T	T	T	T	T	T	T	T	T	T
		5	T			5	T	T	T	T	T	T	T	T	T	T	T
			5				5	T	T	T	T	T	T	T	T	T	T
5		T	T	3	T	T	T	T	40	40	40	40	40	40	40	T	T
		T	T		5	T	T	T	40	40	40	40	40	40	40	T	T
		5	T			5	T	T	40	40	40	40	40	40	40	T	T
			5				5	T	40	40	40	40	40	40	40	T	T
5		5	5	T	T	T	T	T	T	T	T	T	T	T	T	T	T
5		5	5	T	T	T	T	T	T	T	T	T	T	T	T	T	T
		5	5				T	T	T	T	T	T	T	T	T	T	T
			5					T	T	T	T	T	T	T	T	T	T
							8	8	30	30	30	30	30	30	30	T	T
								8	30	30	30	30	30	30	30	T	T
									30	30	30	30	30	30	30	T	T
									30	30	30	30	30	30	30	T	T
							8	8	12	12	12	12	12	12	12	15	15
								8	12	12	12	12	12	12	12	15	15
									12	12	12	12	12	12	12	15	15
									12	12	12	12	12	12	12	15	15
							8	8	30	30	30	30	30	30	30	T	T
								8	30	30	30	30	30	30	30	T	T
									30	30	30	30	30	30	30	T	T
									30	30	30	30	30	30	30	T	T
									30	30	30	30	30	30	30	T	T

Upstream Downstream In (A) Ii (kA)		NM8-125 S/H/R										NM8-250 S/H/R			
		16	20	25	32	40	50	63	80	100	125	100	160	200	250
NM8S-630 S/H/R	250														
	315														
	350														
	400														
	500														
	630														
NM8-800 S/H	630														
	700														
	800														
NM8S-800 S/H	630														
	700														
	800														
NM8-1250 S/H	630														
	700														
	800														
	1000														
	1250														
NM8S-1250 S/H	630														
	700														
	800														
	1000														
	1250														
NM8S-1600 S/H	1000														
	1250														
	1600														

Upstream: NM8S-125~1250
Downstream: NM8(S)-125~1250

Upstream Downstream In (A) Ii (kA)		NM8S-125 S/H			NM8S-250 S/H				NM8S-400 S/H/R			
		40	100	125	100	160	200	250	250	315	350	400
NM8-125 S	16		1.2	1.2	1.2	T	T	T	T	T	T	T
	20		1.2	1.2	1.2	T	T	T	T	T	T	T
	25		1.2	1.2	1.2	T	T	T	T	T	T	T
	32		1.2	1.2	1.2	T	T	T	T	T	T	T
	40		1.2	1.2	1.2	T	T	T	T	T	T	T
	50		1.2	1.2	1.2	T	T	T	T	T	T	T
	63			1.2	1.2	T	T	T	T	T	T	T
	80					T	T	T	T	T	T	T
	100						T	T	T	T	T	T
	125							T	T	T	T	T
NM8-125 H/R	16		1.2	1.2	1.2	T	T	T	T	T	T	T
	20		1.2	1.2	1.2	T	T	T	T	T	T	T
	25		1.2	1.2	1.2	T	T	T	T	T	T	T
	32		1.2	1.2	1.2	T	T	T	T	T	T	T
	40		1.2	1.2	1.2	T	T	T	T	T	T	T
	50		1.2	1.2	1.2	2	36	36	T	T	T	T
	63			1.2	1.2	2	36	36	T	T	T	T
	80					2	36	36	T	T	T	T
	100							36	T	T	T	T
	125							36	T	T	T	T
NM8S-125 S/H	40		1.2	1.2	2	2	T	T	T	T	T	T
	100					2	T	T	T	T	T	T
	125							T	T	T	T	T

Moulded Case Circuit Breakers
NM8, NM8S



NM8-400 S/H/R				NM8-630 S/H/R					NM8-800 S/H			NM8-1250 S/H				
250	315	350	400	250	315	350	400	500	630	700	800	630	700	800	1000	1250
							8	8	12	12	12	12	12	12	15	15
								8	12	12	12	12	12	12	15	15
									12	12	12	12	12	12	15	15
									12	12	12	12	12	12	15	15
										12	12	12	12	12	15	15
											12			12	15	15
															15	15
															15	15
															15	15

NM8S-630 S/H/R						NM8S-800 S/H			NM8S-1250,1600 S/H				
250	315	350	400	500	630	630	700	800	630	700	800	1000	1250
T	T	T	T	T	T	T	T	T	T	T	T	T	T
T	T	T	T	T	T	T	T	T	T	T	T	T	T
T	T	T	T	T	T	T	T	T	T	T	T	T	T
T	T	T	T	T	T	T	T	T	T	T	T	T	T
T	T	T	T	T	T	T	T	T	T	T	T	T	T
T	T	T	T	T	T	T	T	T	T	T	T	T	T
T	T	T	T	T	T	T	T	T	T	T	T	T	T
T	T	T	T	T	T	T	T	T	T	T	T	T	T
T	T	T	T	T	T	T	T	T	T	T	T	T	T
T	T	T	T	T	T	T	T	T	T	T	T	T	T
T	T	T	T	T	T	T	T	T	T	T	T	T	T
T	T	T	T	T	T	T	T	T	T	T	T	T	T
T	T	T	T	T	T	T	T	T	T	T	T	T	T
T	T	T	T	T	T	T	T	T	T	T	T	T	T
T	T	T	T	T	T	T	T	T	T	T	T	T	T
T	T	T	T	T	T	T	T	T	T	T	T	T	T
T	T	T	T	T	T	T	T	T	T	T	T	T	T
T	T	T	T	T	T	T	T	T	T	T	T	T	T
T	T	T	T	T	T	T	T	T	T	T	T	T	T
T	T	T	T	T	T	T	T	T	T	T	T	T	T
T	T	T	T	T	T	T	T	T	T	T	T	T	T
T	T	T	T	T	T	T	T	T	T	T	T	T	T

	NM8S-125 S/H			NM8S-250 S/H				NM8S-400 S/H/R			
	40	100	125	100	160	200	250	250	315	350	400
40		1.2	1.2	2	2	T	T	T	T	T	T
100					2	T	T	T	T	T	T
125							T	T	T	T	T
NM8-250 S	100						3	5	5	5	5
	160									5	5
	200										
	250										
NM8-250 H/R	100						3	5	5	5	5
	160									5	5
	200										
	250										
NM8S-250 S/H	100						5	5	5	5	5
	160						5	5	5	5	5
	200									5	5
	250										5
NM8-400 S/H/R	250										
	315										
	350										
	400										
NM8S-400 S/H/R	250										
	315										
	350										
	400										
NM8-630 S/H/R	250										
	315										
	350										
	400										
	500										
NM8S-630 S/H/R	250										
	315										
	350										
	400										
NM8-800 S/H	500										
	630										
	700										
NM8S-800 S/H	630										
	700										
	800										
NM8-1250 S/H	800										
	1000										
	1250										
	1600										
	2000										
NM8S-1250 S/H	630										
	700										
	800										
	1000										
	1250										
NM8S-1600 S/H	1000										
	1250										
	1600										

Note:

- a. The area with T indication clarifies total protection discrimination between upstream and downstream circuit breakers;
- b. The area with numbers clarifies partial protection discrimination between upstream and downstream circuit breakers;
- c. For partial protection discrimination, the Max. fault current values to ensure time discrimination performance are given in the table; when fault current exceeds this value, upstream and downstream circuit breakers may operate at the same time.

NM8S-630 S/H/R						NM8S-800 S/H			NM8S-1250 S/H					NM8S-1600 S/H		
250	315	350	400	500	630	630	700	800	630	700	800	1000	1250	1000	1250	1600
T	T	T	T	T	T	T	T	T	T	T	T	T	T	T	T	T
T	T	T	T	T	T	T	T	T	T	T	T	T	T	T	T	T
T	T	T	T	T	T	T	T	T	T	T	T	T	T	T	T	T
T	T	T	T	T	T	T	T	T	T	T	T	T	T	T	T	T
			T	T	T	T	T	T	T	T	T	T	T	T	T	T
				T	T	T	T	T	T	T	T	T	T	T	T	T
					T	T	T	T	T	T	T	T	T	T	T	T
T	T	T	T	T	T	40	40	40	40	40	40	T	T	T	T	T
			T	T	T	40	40	40	40	40	40	T	T	T	T	T
				T	T	40	40	40	40	40	40	T	T	T	T	T
					T	40	40	40	40	40	40	T	T	T	T	T
T	T	T	T	T	T	T	T	T	T	T	T	T	T	T	T	T
T	T	T	T	T	T	T	T	T	T	T	T	T	T	T	T	T
			T	T	T	T	T	T	T	T	T	T	T	T	T	T
				T	T	T	T	T	T	T	T	T	T	T	T	T
			8	8	8	30	30	30	30	30	30	T	T	T	T	T
				8	8	30	30	30	30	30	30	T	T	T	T	T
					8	30	30	30	30	30	30	T	T	T	T	T
					8	30	30	30	30	30	30	T	T	T	T	T
			8	8	8	12	12	12	12	12	12	15	15	15	15	15
				8	8	12	12	12	12	12	12	15	15	15	15	15
					8	12	12	12	12	12	12	15	15	15	15	15
					8	12	12	12	12	12	12	15	15	15	15	15
				8	8	30	30	30	30	30	30	T	T	T	T	T
				8	8	30	30	30	30	30	30	T	T	T	T	T
					8	30	30	30	30	30	30	T	T	T	T	T
					8	30	30	30	30	30	30	T	T	T	T	T
							30	30		30	30	T	T	T	T	T
				8	8	12	12	12	12	12	12	15	15	15	15	15
				8	8	12	12	12	12	12	12	15	15	15	15	15
					8	12	12	12	12	12	12	15	15	15	15	15
					8	12	12	12	12	12	12	15	15	15	15	15
							12	12	12	12	12	15	15	15	15	15
												20	20	20	20	20
												15	15	15	15	15
												20	20	20	20	20
												15	15	15	15	15

10.7 Selection table of components for motor control or protection
 400V, 50kA, type2, MCCB normal load start-up

Motor parameters		Circuit breaker parameters		Contactor parameters		Thermal relay parameters	
Rated power (kW)	Rated current (A)	Model	Setting of magnetic protection (A)	Model	Rated heating current (A)	Model	Rated current (A)
5.5	10.9	NM8-125S/16M	192	NC1-12	20	NR2-25	9~13
7.5	14.4	NM8-125S/20M	240	NC1-18	32	NR2-25	12~18
11	20.9	NM8-125S/25M	300	NC1-25	40	NR2-25	17~25
15	28	NM8-125S/32M	384	NC1-32	50	NR2-36	23~32
18.5	34.1	NM8-125S/40M	480	NC1-40	60	NR2-36	28~36
22	39.4	NM8-125S/50M	600	NC1-50	80	NR2-93	30~40
30	53.4	NM8-125S/63M	756	NC1-65	80	NR2-93	48~65
37	67.9	NM8-125S/80M	960	NC1-80	110	NR2-93	55~70
45	80.5	NM8-125S/100M	1200	NC1-95	110	NR2-93	80~93
55	98.5	NM8-125S/125M	1500	NC2-115	200	NR2-200	80~125
75	133	NM8-250S/160M	1920	NC2-150	200	NR2-200	100~160
90	158.7	NM8-250S/200M	2400	NC2-185	275	NR2-200	100~160
110	192	NM8-250S/250M	3000	NC2-225	275	NR2-200	125~200
132	229	NM8-400S/315M	3780	NC2-265	315	NR2-630	160~250
160	275	NM8-400S/350M	4200	NC2-330	380	NR2-630	200~315
200	343	NM8-400S/400M	4800	NC2-400	450	NR2-630	250~400
250	445	NM8-630S/500M	6000	NC2-500	630	NR2-630	315~500
290	520	NM8S-630S/630M	7560	NC2-630	800	NR2-630	400~630
315	560	NM8S-630S/630M	7560	NC2-630	800	NR2-630	400~630

Note:

1. NM8 and NM8S breakers can replace each other with the same capacity in the table above .
2. NRE8 electronic relays and NR2 thermal relays can replace each other with the same capacity in the table above.

400V, 50kA, type2, MCCB heavy-load start-up

Motor parameters		Circuit breaker parameters		Contactor parameters		Thermal relay parameters	
Rated power (kW)	Rated current (A)	Model	Setting of magnetic protection (A)	Model	Rated heating current (A)	Model	Rated current (A)
5.5	10.9	NM8-125S/16M	192	NC1-18	32	NR2-25	9~13
7.5	14.4	NM8-125S/20M	240	NC1-25	40	NR2-25	12~18
11	20.9	NM8-125S/25M	300	NC1-32	50	NR2-25	17~25
15	28	NM8-125S/32M	384	NC1-40	60	NR2-36	23~32
18.5	34.1	NM8-125S/40M	480	NC1-50	80	NR2-36	28~36
22	39.4	NM8-125S/50M	600	NC1-65	80	NR2-93	30~40
30	53.4	NM8-125S/63M	756	NC1-80	110	NR2-93	48~65
37	67.9	NM8-125S/80M	960	NC1-95	110	NR2-93	55~70
45	80.5	NM8-125S/100M	1200	NC2-115	200	NR2-93	80~93
55	98.5	NM8-125S/125M	1500	NC2-150	200	NR2-200	80~125
75	133	NM8-250S/160M	1920	NC2-185	275	NR2-200	100~160
90	158.7	NM8-250S/200M	2400	NC2-225	275	NR2-200	100~160
110	192	NM8-250S/250M	3000	NC2-265	315	NR2-200	125~200
132	229	NM8-400S/315M	3780	NC2-330	380	NR2-630	160~250
160	275	NM8-400S/350M	4200	NC2-400	450	NR2-630	200~315
200	343	NM8-400S/400M	4800	NC2-500	630	NR2-630	250~400
250	445	NM8-630S/500M	6000	NC2-630	800	NR2-630	315~500
290	520	NM8S-630S/630M	7560	NC2-630	800	NR2-630	400~630

Note:

1. NM8 and NM8S breakers can replace each other with the same capacity in the table above .
2. NRE8 electronic relays and NR2 thermal relays can replace each other with the same capacity in the table above.

400V, 50kA, type2, MCCB star-delta start-up

Motor parameters		Circuit breaker parameters		Contactor parameters			Thermal relay parameters	
Rated power (kW)	Rated current (A)	Model	Setting of magnetic protection (A)	Feedback contactor	Delta contactor	Star contactor	Model	Rated current (A)
5.5	10.9	NM8-125S/16M	192	NC1-09	NC1-09	NC1-09	NR2-11.5	5.5~8
7.5	14.4	NM8-125S/20M	240	NC1-12	NC1-12	NC1-09	NR2-11.5	7~10
11	20.9	NM8-125S/25M	300	NC1-18	NC1-18	NC1-09	NR2-25	9~13
15	28	NM8-125S/32M	384	NC1-25	NC1-25	NC1-12	NR2-25	12~18
18.5	34.1	NM8-125S/40M	480	NC1-25	NC1-25	NC1-18	NR2-25	17~25
22	39.4	NM8-125S/50M	600	NC1-32	NC1-32	NC1-18	NR2-36	23~32
30	53.4	NM8-125S/63M	756	NC1-40	NC1-40	NC1-25	NR2-36	28~36
37	67.9	NM8-125S/80M	960	NC1-50	NC1-50	NC1-32	NR2-93	30~40
45	80.5	NM8-125S/100M	1200	NC1-65	NC1-65	NC1-32	NR2-93	37~50
55	98.5	NM8-125S/125M	1500	NC1-80	NC1-80	NC1-40	NR2-93	48~65
75	133	NM8-250S/160M	1920	NC1-95	NC1-95	NC1-50	NR2-93	63~80
90	158.7	NM8-250S/200M	2400	NC2-115	NC2-115	NC2-65	NR2-93	80~93
110	192	NM8-250S/250M	3000	NC2-150	NC2-150	NC2-80	NR2-200	80~125
132	229	NM8-400S/315M	3780	NC2-150	NC2-150	NC2-95	NR2-200	80~125
160	275	NM8-400S/350M	4200	NC2-185	NC2-185	NC2-115	NR2-200	100~160
200	343	NM8-400S/400M	4800	NC2-225	NC2-225	NC2-150	NR2-200	125~200
250	445	NM8-630S/500M	6000	NC2-330	NC2-330	NC2-185	NR2-630	200~315
290	520	NM8S-630S/630M	7560	NC2-400	NC2-400	NC2-185	NR2-630	200~315
315	560	NM8S-630S/630M	7560	NC2-400	NC2-400	NC2-225	NR2-630	250~400

Note:

1. NM8 and NM8S breakers can replace each other with the same capacity in the table above .
2. NRE8 electronic relays and NR2 thermal relays can replace each other with the same capacity in the table above.
3. Breaker is at the power supply side
4. In the delta connection circuit of thermal relay, the setting value is 0.58Ie;
5. The max. start-up time is 20s;
6. When Star type connection is changed into delta connection, the following connection modes of motor are recommended: L1, U1 to V2; L2, V1 to W2; L3, W1 to U2 to lower the impulse current;
7. The interval of star type connection changing into delta connection is 0.1s.



Helsinki
 tel. +358 9 540 4940
 info@klinkmann.fi

St. Petersburg
 tel. +7 812 327 3752
 klinkmann@klinkmann.spb.ru

Moscow
 tel. +7 495 641 1616
 moscow@klinkmann.spb.ru

Yekaterinburg
 tel. +7 343 287 19 19
 yekaterinburg@klinkmann.spb.ru

Samara
 tel. +7 846 273 95 85
 samara@klinkmann.spb.ru

Kiev
 tel. +38 044 495 33 40
 klinkmann@klinkmann.kiev.ua

Riga
 tel. +371 6738 1617
 klinkmann@klinkmann.lv

Vilnius
 tel. +370 5 215 1646
 post@klinkmann.lt

Tallinn
 tel. +372 668 4500
 klinkmann.est@klinkmann.ee

Minsk
 tel. +375 17 200 0876
 minsk@klinkmann.com