



NA1-1000
200A to 1000A



NA1-2000
630A to 2000A



NA1-3200, 4000
2000A to 4000A



NA1-6300
4000A to 6300A



Summary

5 basic frame sizes

For your various requirements, the Air Circuit Breaker NA1 includes 5 basic frame sizes as followed.

1. General

1.1 Application scope

NA1 series air circuit breaker is suitable for the circuit of AC 50Hz/60Hz with rated service voltage 400V, 690V and rated service current up to 6300A. It is mainly used to distribute electric energy and protect circuits and electric equipment against over-load, under-voltage, short-circuit and single-phase earthing fault.

With intelligentized and selective protection functions, the breaker can improve the reliability of power supply, and avoid unnecessary power failure. The breaker is applicable for power stations, factories, mines (for 690V) and modern high-buildings, especially for the distribution system of intelligentized building.

1.2 Standard: IEC/EN 60947-2.

2. Operating conditions

2.1 Temperature condition:

-5°C ~40°C; the average value within 24h shall not exceed +35°C (special situation excluded);

2.2 Altitude: ≤2000m;

2.3 Pollution grade: Grade 3;

2.4 Air conditions:

At mounting site, relative humidity not exceed 50% at the max temperature of +40°C, higher relative humidity is allowable under lower temperature, RH could be 90% at +20°C, special measures should be taken to occurrence of dews;

2.5 Note: Without the intelligent controller, the breaker functions as a switch-disconnector.

2.6 Type designation

NA1 - □-□□ / □-□-□-□-□

Voltage of secondary circuit
AC220V, AC380V,
AC230V, AC400V
DC220V, DC110V

Wiring of main circuit:
H:Horizontal wiring of main circuit
V:Vertical wiring of main circuit

Mode of installation:
F:Fixed type
D:Draweout type

Mode of operation:
M:Manual
P: Power-driven

No. of poles:
3:3-pole
4:4-pole

Intelligent controller:
M: Standard type
3M: Multifunctional type
3H: Communication type

Rated current:

Frame size rated current	Rated current
1000A	200A
	400A
	630A
	800A
	1000A
2000A	630A
	800A
	1000A
	1250A
	1600A
	2000A
3200A	2000A
	2500A
	3200A
4000A	4000A
6300A	4000A
	5000A
	6300A

Frame size rated current:
1000A, 2000A, 3200A,4000A, 6300A

Design sequence number

ACB

Company code

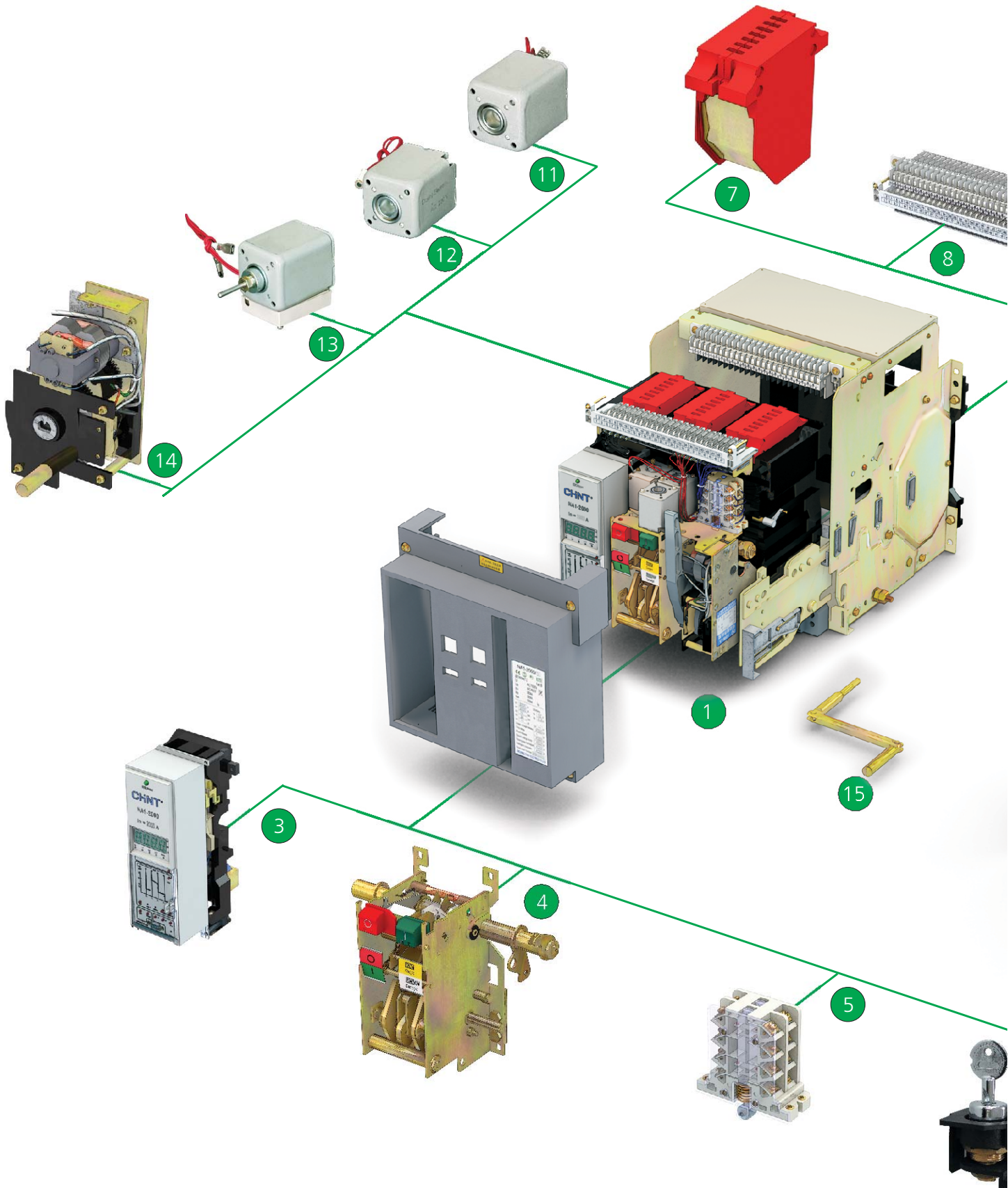

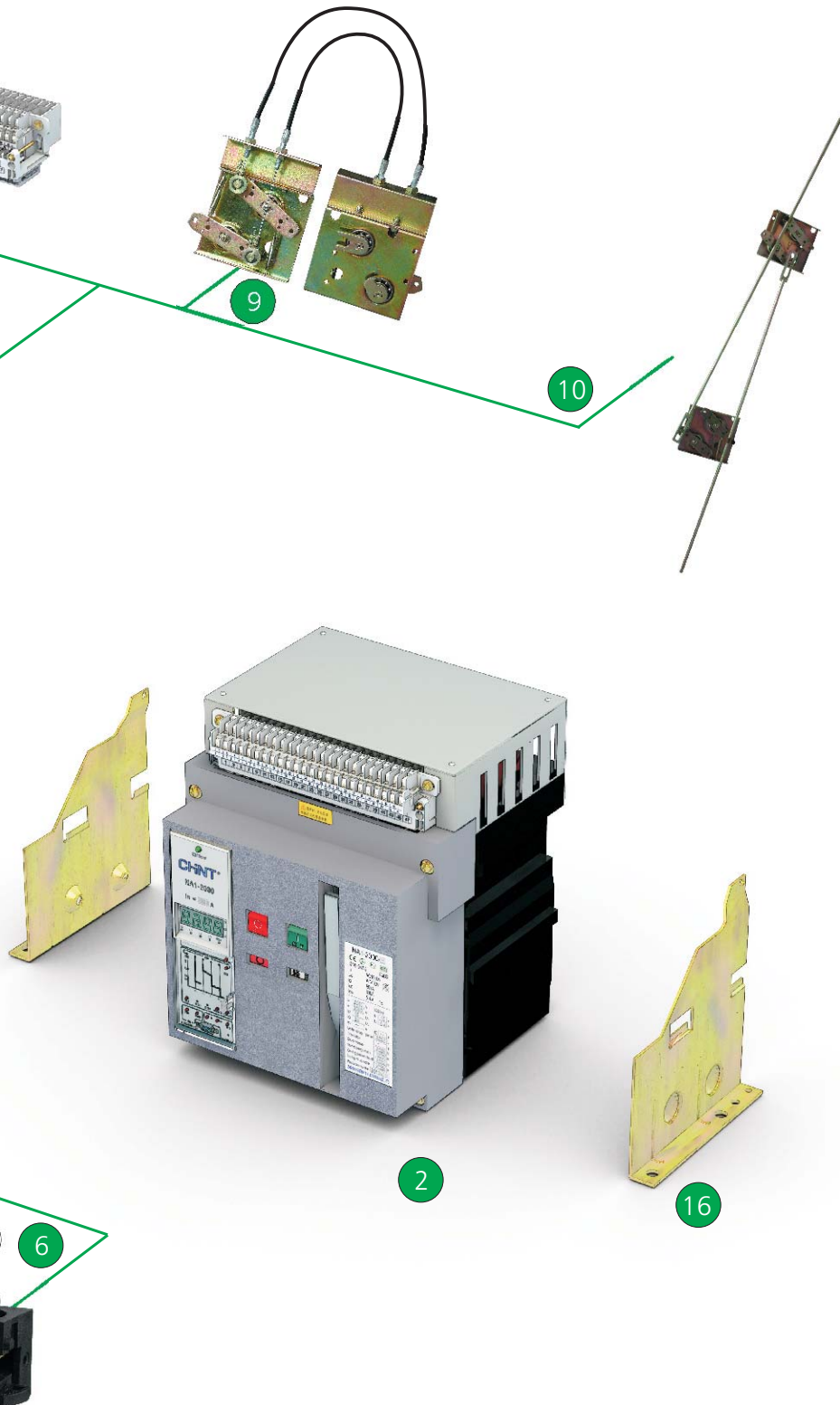



NA1 Air Circuit Breaker

- 1 Drawout type
- 2 Fixed type
- 3 Intelligent controller
- 4 Operating mechanism
- 5 Auxiliary contact
- 6 Locking-device
- 7 Arcing chamber
- 8 Secondary connecting part
- 9 Wire-cable mechanical interlock
- 10 Connecting-rod type mechanical interlock
- 11 Shunt release
- 12 Closing electromagnet
- 13 Under-voltage release
- 14 Motor-driven energy-storage mechanism
- 15 Rotary handle
- 16 Fixed plate

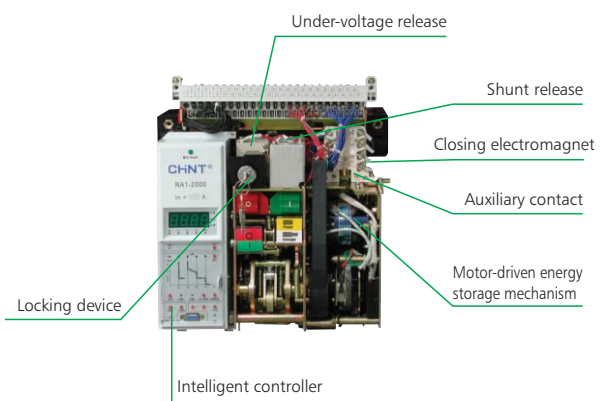
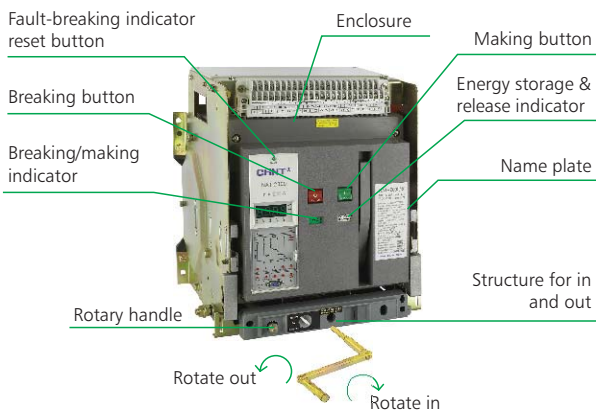
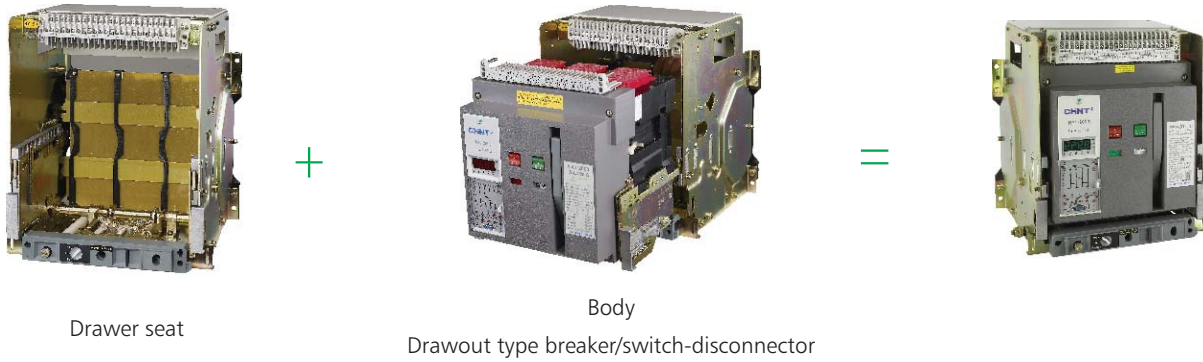
3. Structure



4. Main technical parameter

Type		NA1-1000				
						
Rated ultimate short circuit breaking capacity		$I_{cu}=42kA$ AC 400V 25kA AC 690V				
Rated service short circuit breaking capacity		$I_{cs}=30kA$ AC 400V 20kA AC 690V				
Rated short-time withstand current		$I_{cw}=30kA / 1s$ AC 400V 20kA / 1s AC 690V				
Rated current I_n (A)		200	400	630	800	1000
Number of poles		3, 4				
Rated voltage U_e (V)		AC 400, AC 690				
Rated insulation voltage U_i (V)		AC 800				
Rated current of N-pole I_n (A)		100% I_n				
Fixed disconnection time (ms)		23~32				
Intelligent controller	Standard type (M)	●	●	●	●	●
	Communication type (H)	●	●	●	●	●
Operation performance	Electric life	AC 400V:6500, AC 690V:3000				
	Mechanical life	Non-maintenance 15,000				
		Maintenance 30,000				
Connection pattern		Horizontal, Vertical				
Motor operational standard configuration weight (kg)	Drawout 3P/4P	38/55				
	Fixed 3P/4P	22/26.5				

Standard configuration: M type intelligent controller; Under-voltage release; Shunt release; Motor-driven energy-storage mechanism

Type		NA1-2000					
							
Rated ultimate short circuit breaking capacity		$I_{cu}=80kA$ AC 400V 50kA AC 690V					
Rated service short circuit breaking capacity		$I_{cs}=50kA$ AC 400V 40kA AC 690V					
Rated short-time withstand current		$I_{cw}=50kA / 1s$ AC 400V 40kA / 1s AC 690V					
Rated current I_n (A)		630	800	1000	1250	1600	2000
Number of poles		3, 4					
Rated voltage U_e (V)		AC 400, AC 690					
Rated insulation voltage U_i (V)		AC 1000					
Rated current of N-pole I_n (A)		100% I_n					
Fixed disconnection time (ms)		23~32					
Intelligent controller	Standard type (M)	●	●	●	●	●	●
	Communication type (H)	●	●	●	●	●	●
Operation performance	Electric life	AC400:6500 AC690V:3000					
	Mechanical life	Non-maintenance 15,000					
		Maintenance 30,000					
Connection pattern		Horizontal, Vertical					
Motor operational standard configuration weight (kg)	Drawout 3P/4P	67.5 / 80		70 / 84		79 / 90.5	
	Fixed 3P/4P	42 / 52		44 / 52		45 / 54	

Type		NA1-3200, NA1-4000			
					
Rated ultimate short circuit breaking capacity		I_{cu} =80kA AC 400V 65kA AC 690V			
Rated service short circuit breaking capacity		I_{cs} =65kA AC 400V 65kA AC 690V			
Rated short-time withstand current		I_{cw} =65kA / 1s AC 400V 50kA / 1s AC 690V			
Rated current I_n (A)		2000	2500	3200	4000
Number of poles		3, 4			3 4
Rated voltage U_e (V)		AC 400, AC 690			
Rated insulation voltage U_i (V)		AC 1000			
Rated current of N-pole I_n (A)		100% I_n			50% I_n
Fixed disconnection time (ms)		23~32			
Intelligent controller	Standard type (M)	●	●	●	●
	Communication type (H)	●	●	●	●
Operation performance	Electric life	AC400V:3000 AC690V:2000			AC400V:1500 AC690V:1000
	Mechanical life	Non-maintenance 10,000			
		Maintenance 20,000			
Connection pattern		Horizontal, Vertical			
Motor operational standard configuration weight (kg)	Drawout 3P/4P	90.5 / 116	90.5 / 116	103 / 130	132 / 172
	Fixed 3P/4P	55 / 68	55 / 68	56.5 / 71	72 / -

Standard configuration: M type intelligent controller; Under-voltage release; Shunt release; Motor-driven energy-storage mechanism

Type		NA1-6300		
				
Rated ultimate short circuit breaking capacity		I_{cu} =120kA AC 400V 85kA AC 690V		
Rated service short circuit breaking capacity		I_{cs} =100kA AC 400V 75kA AC 690V		
Rated short-time withstand current		I_{cw} =100kA / 1s AC 400V 75kA / 1s AC 690V		
rated current I_n (A)		4000	5000	6300
Number of poles		3, 4		3
Rated voltage U_e (V)		AC 400, AC 690		
Rated insulation voltage U_i (V)		AC 1000		
Rated current of N-pole I_n (A)		50% I_n		—
Fixed disconnection time (ms)		23~32		
Intelligent controller	Standard type (M)	●	●	●
	Communication type (H)	●	●	●
Operation performance	Electric life	AC400V:1500 AC690V:1000		
	Mechanical life	Non-maintenance 5000		
		Maintenance 10,000		
Connection pattern		Horizontal, Vertical		
Motor operational standard configuration weight (kg)	Drawout 3P/4P	210 / 233	210 / 233	233 / -
	Fixed 3P/4P	- / -	- / -	- / -

5. Dimensions and connection

NA1-1000 Drawout-type

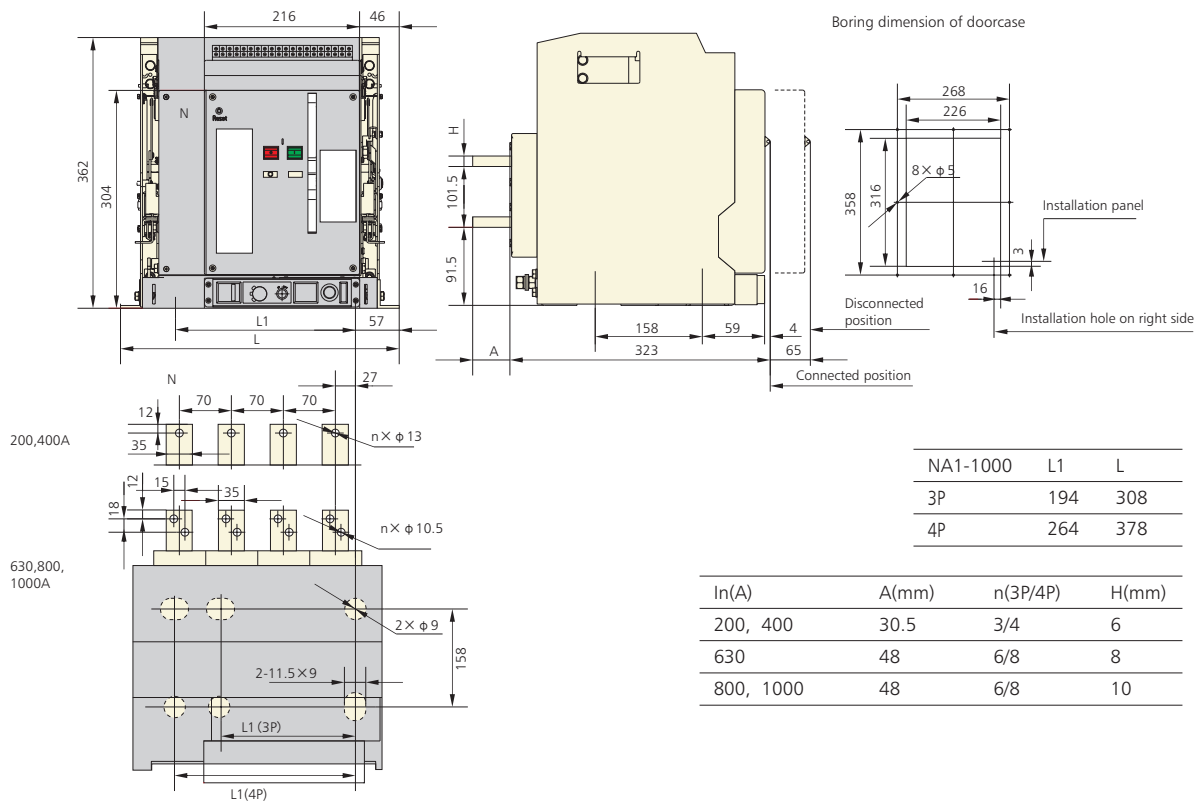

NA1-1000 Fixed-type

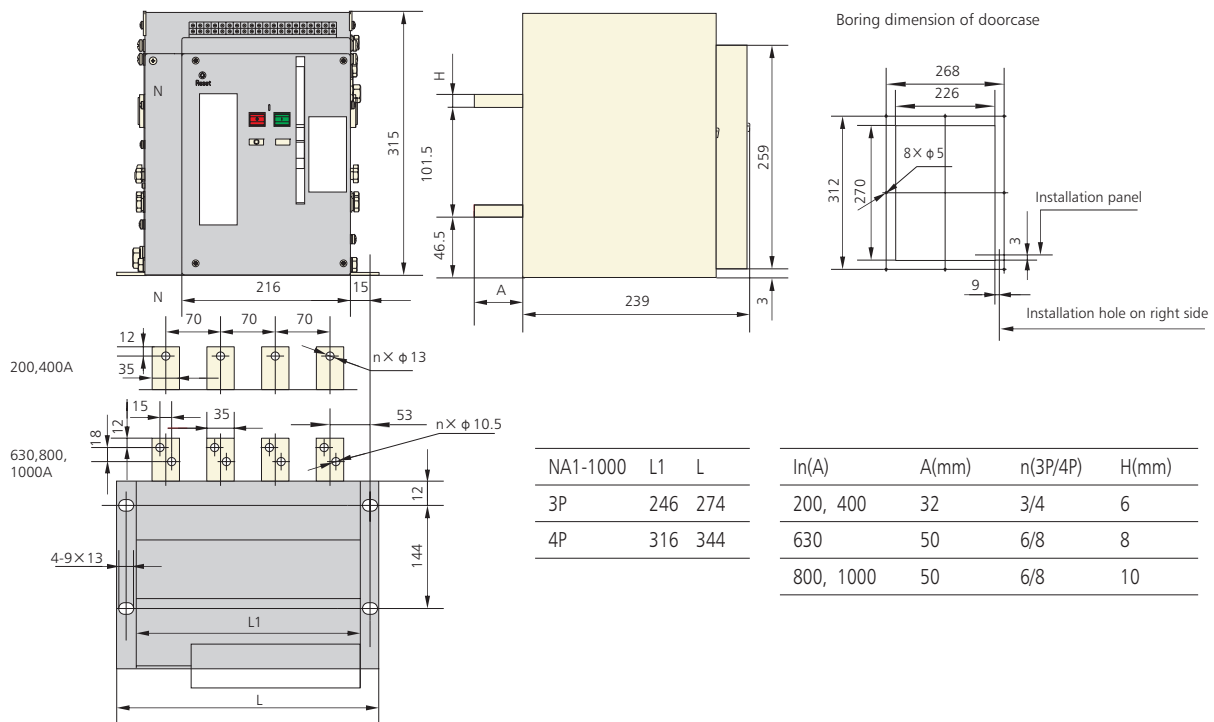

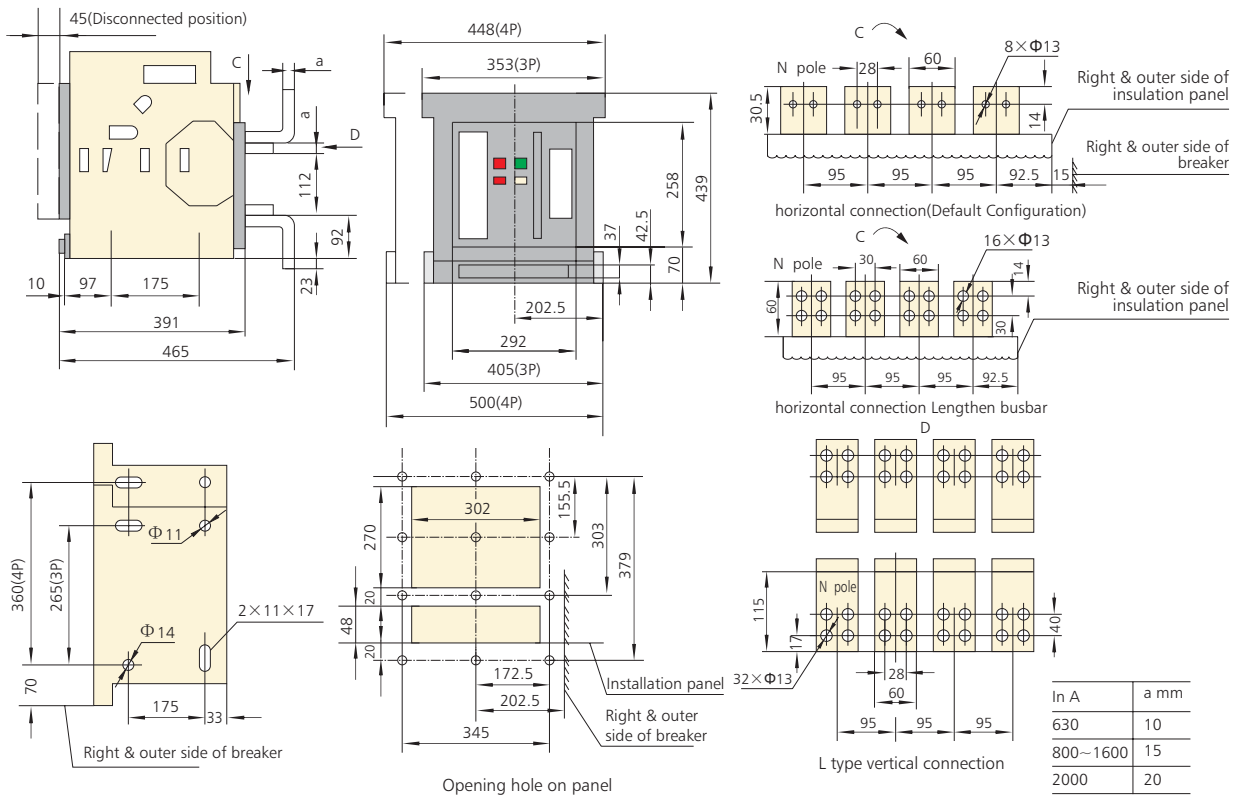

NA1-2000 Drawout-type, vertical, rear connection

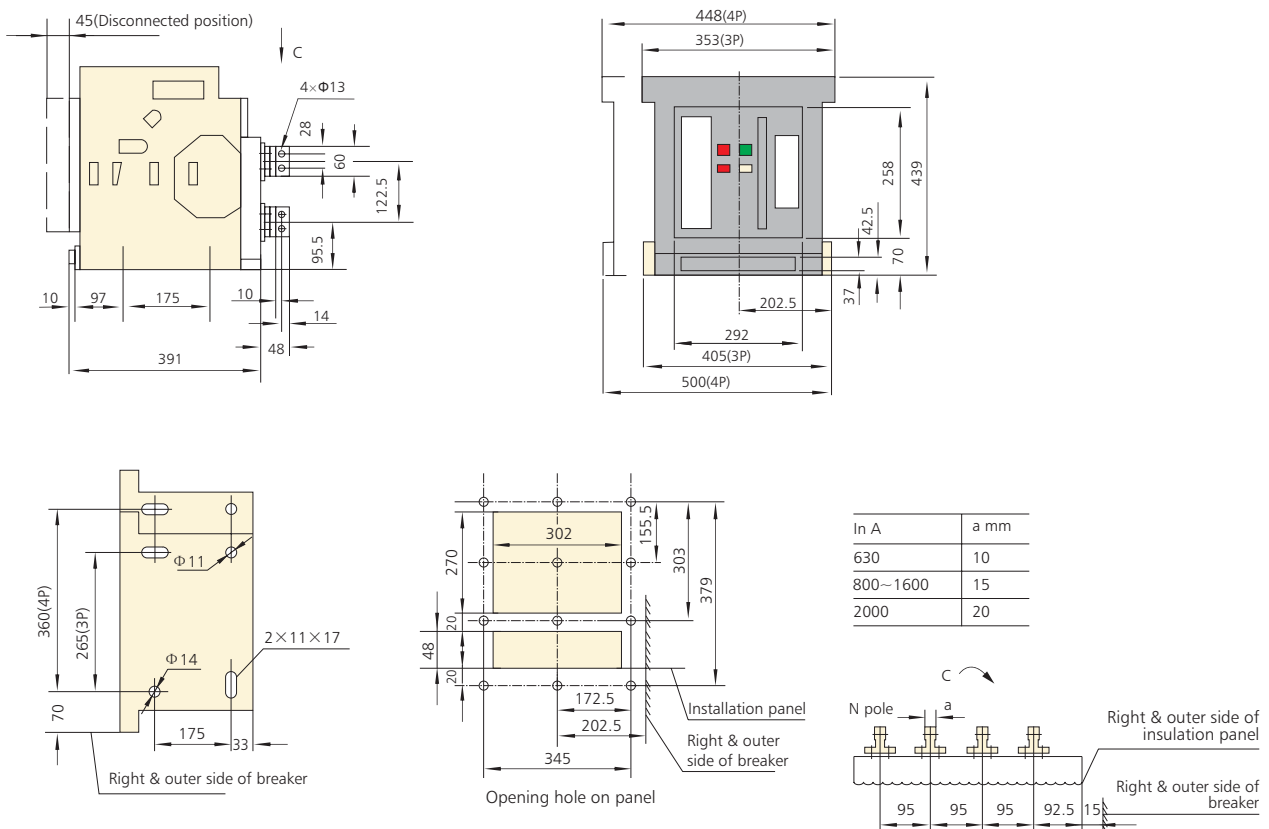

NA1-2000 Drawout-type, horizontal, rear connection

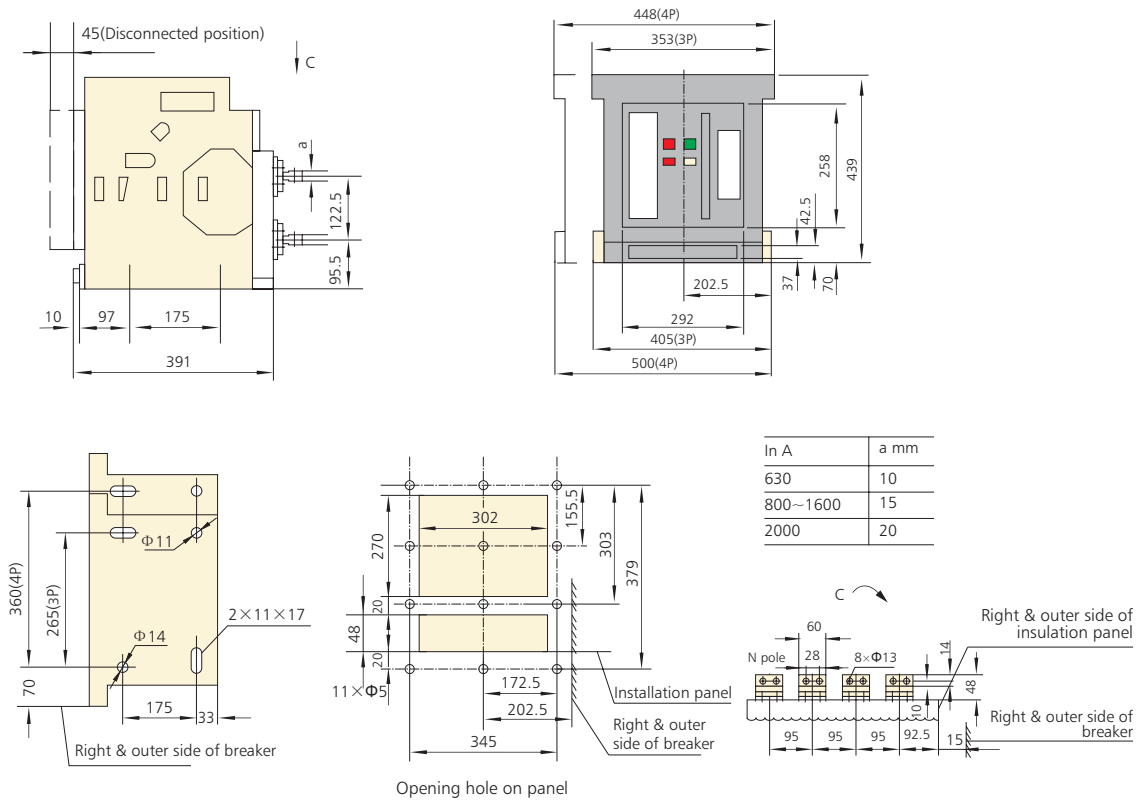

NA1-2000 Fixed-type

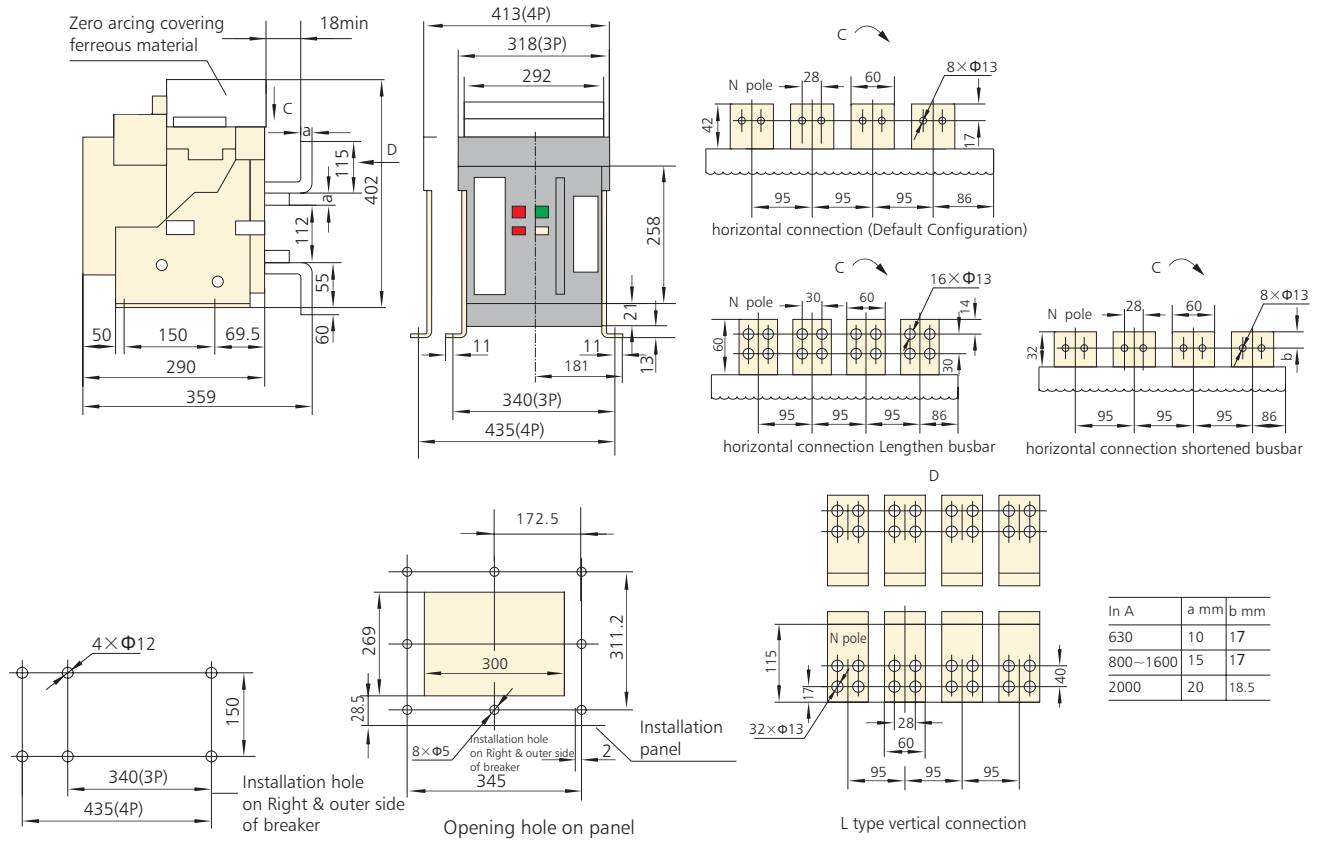

NA1-3200 Drawout-type

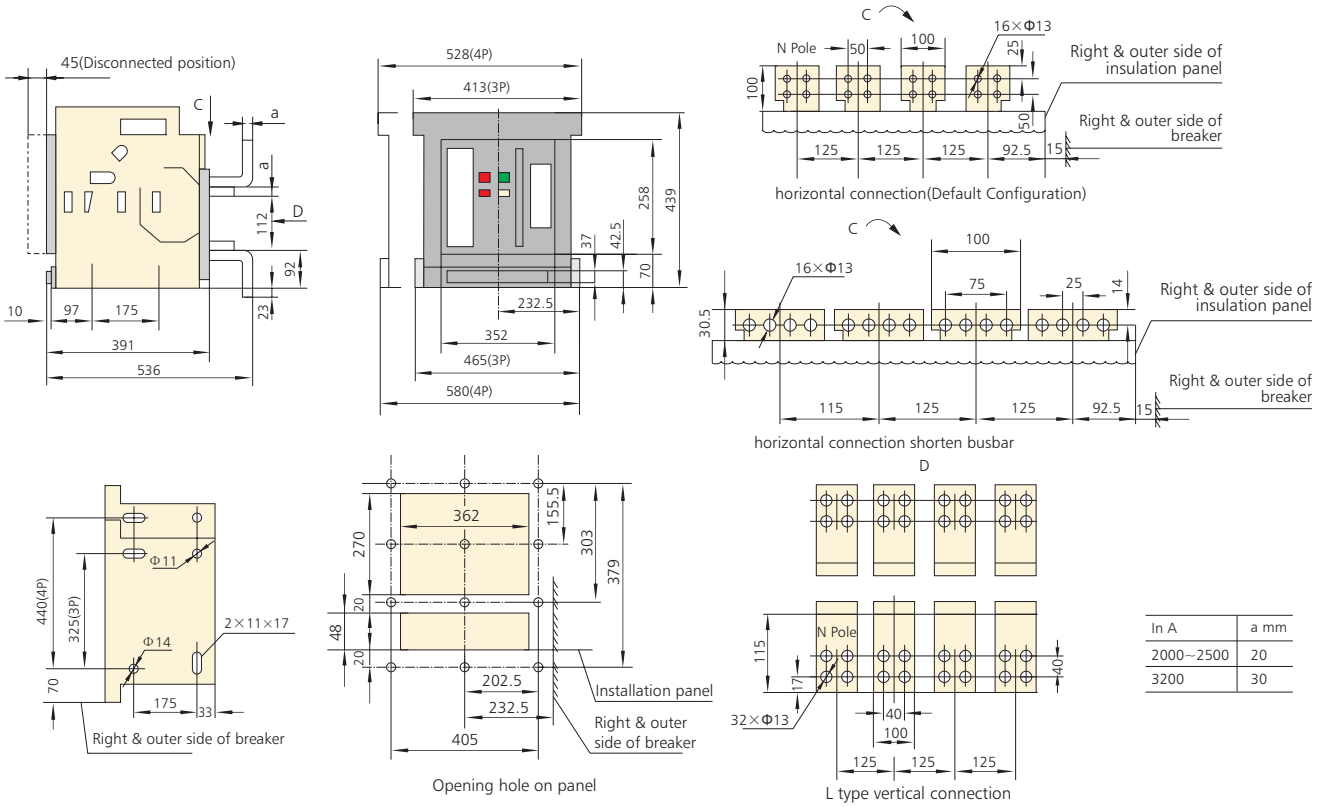

NA1-3200 Drawout-type, horizontal, rear connection

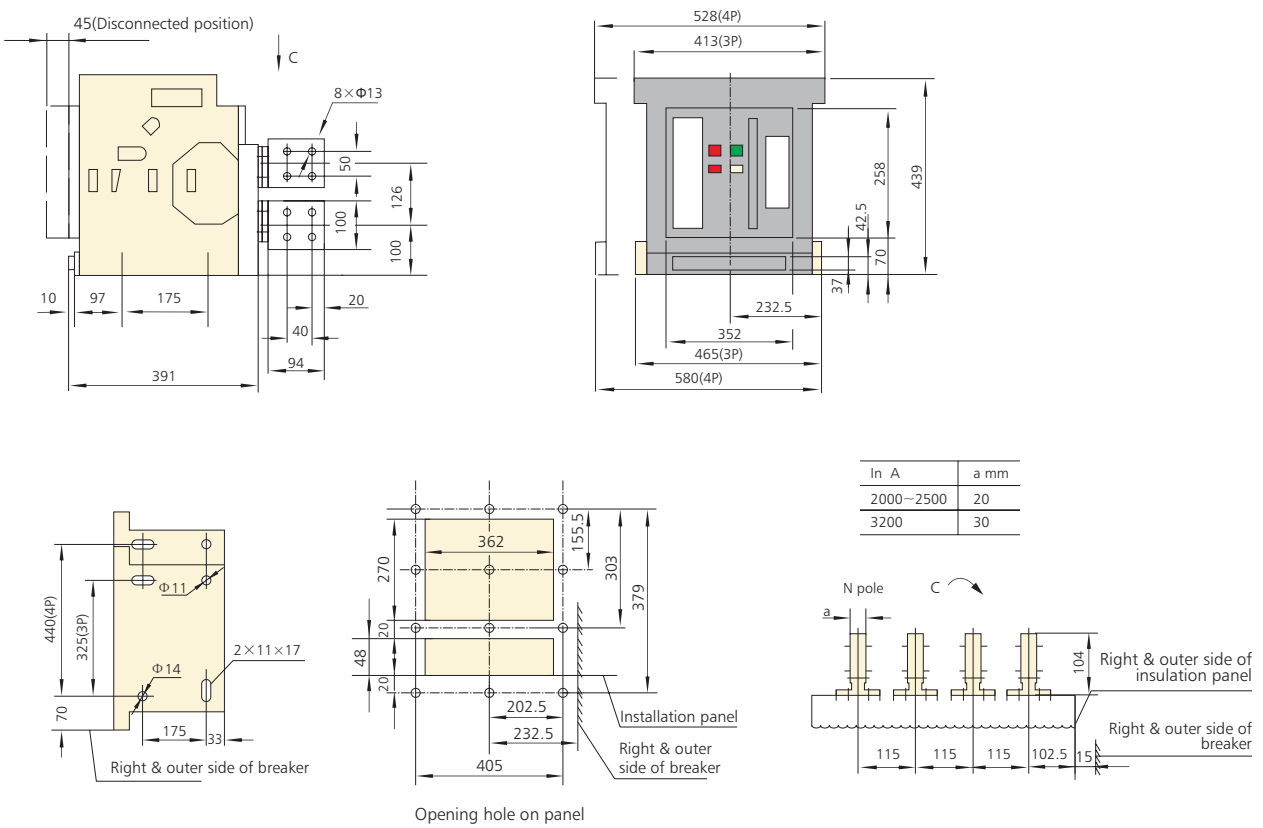

NA1-3200 Drawout-type, horizontal, rear connection

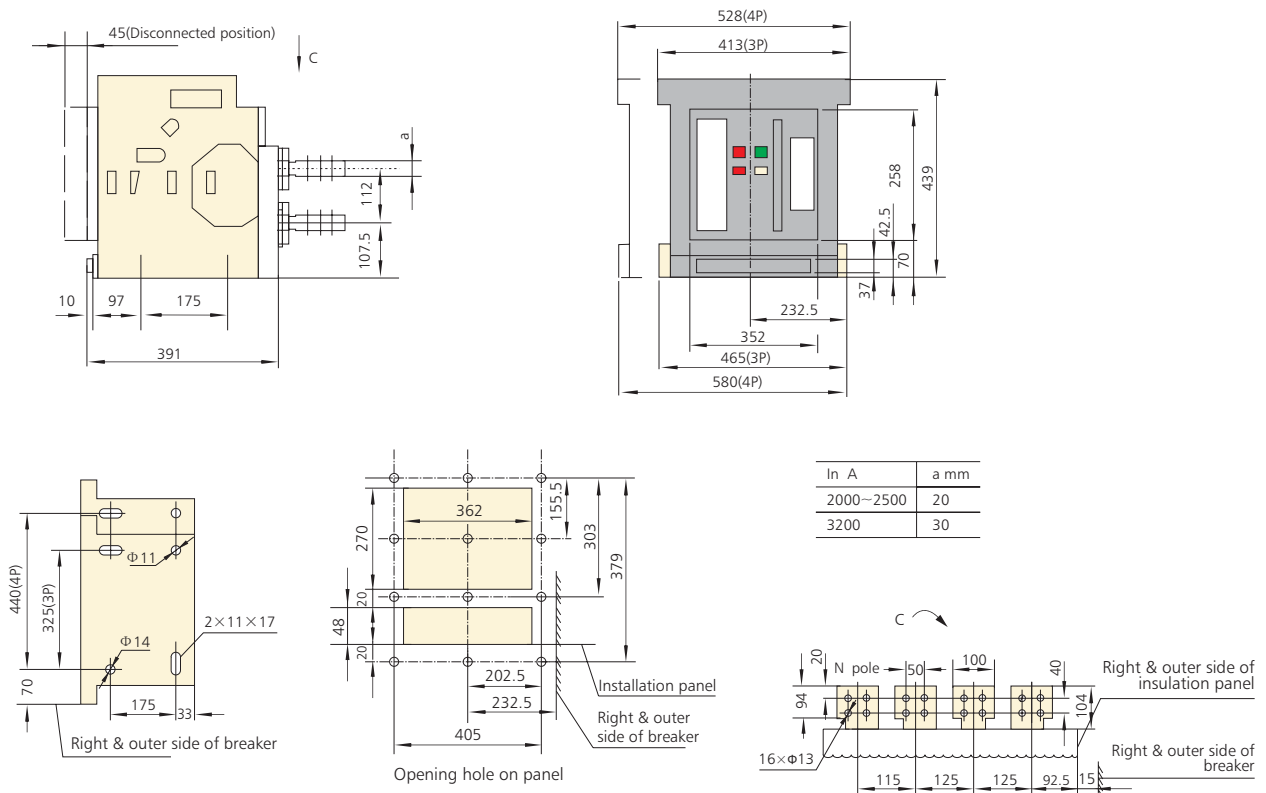

NA1-3200 Fixed-type

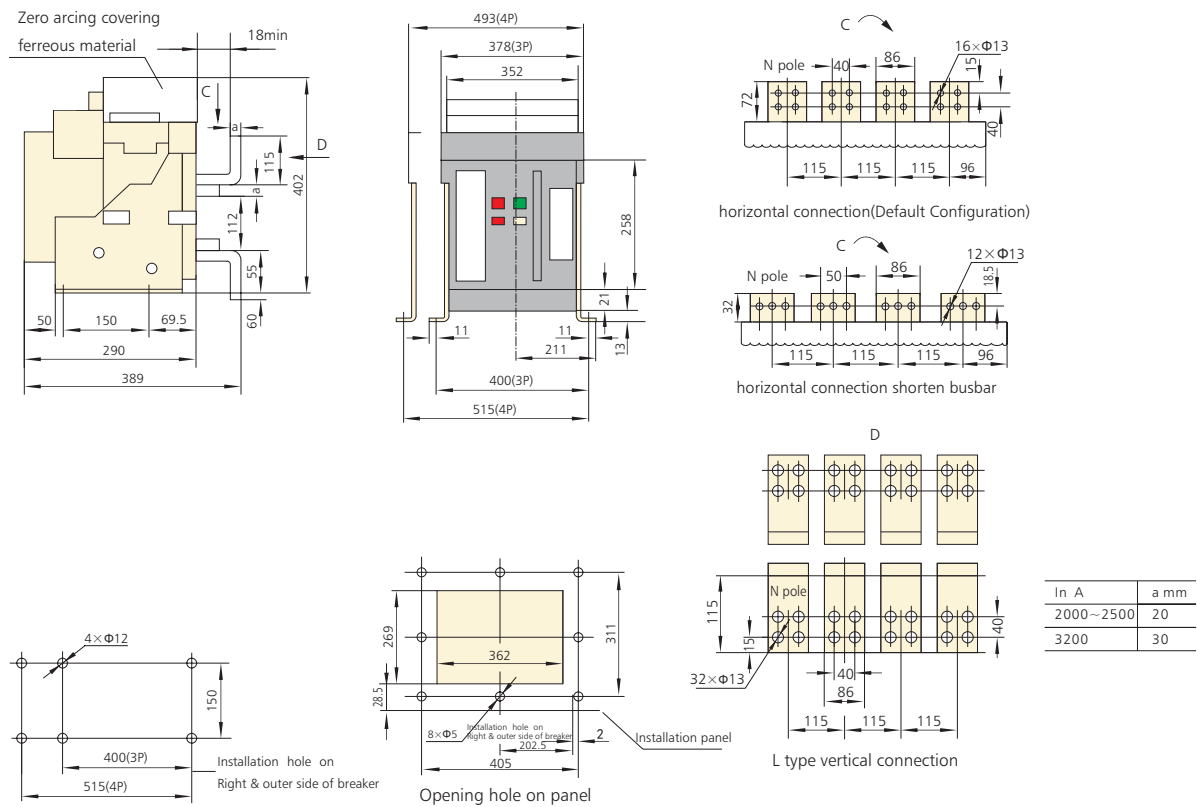

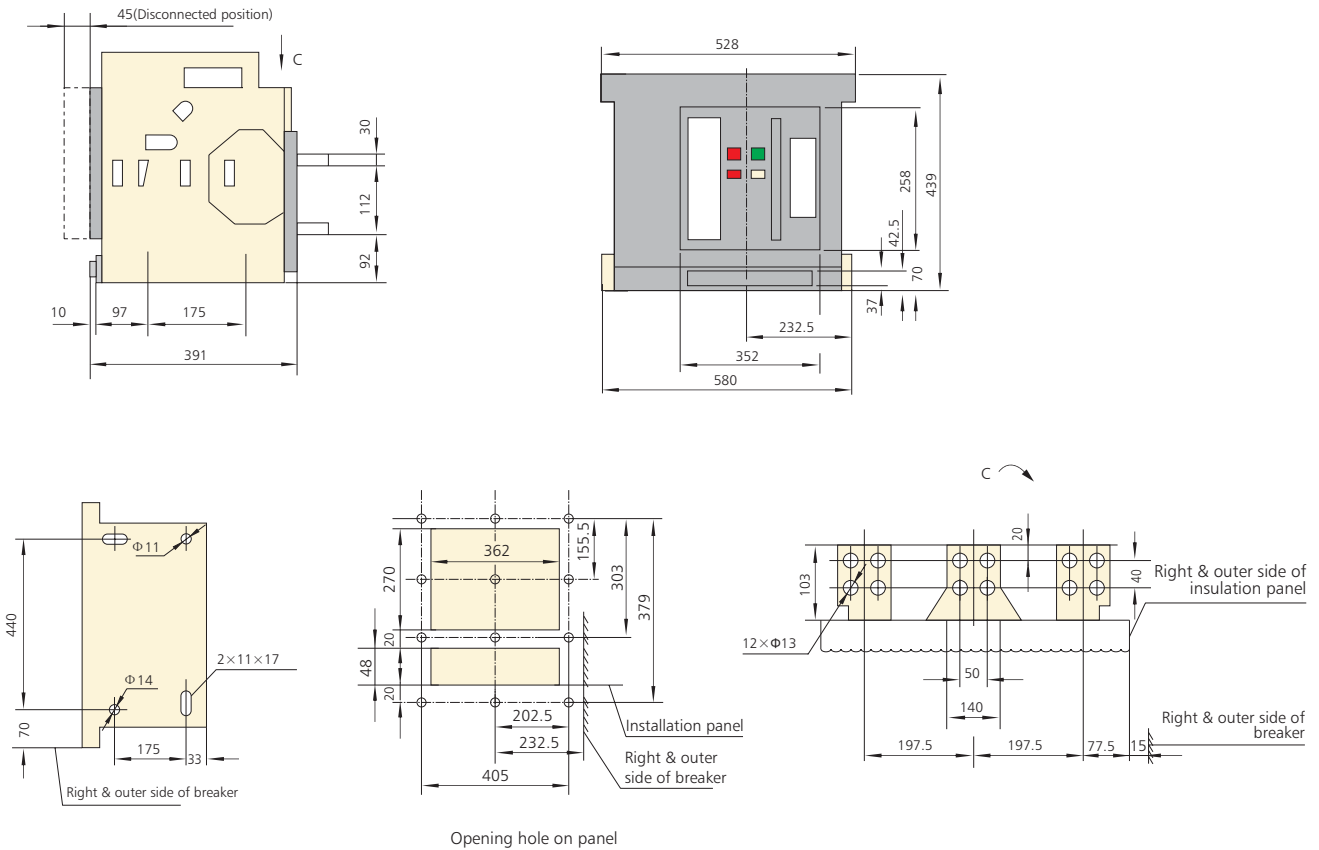
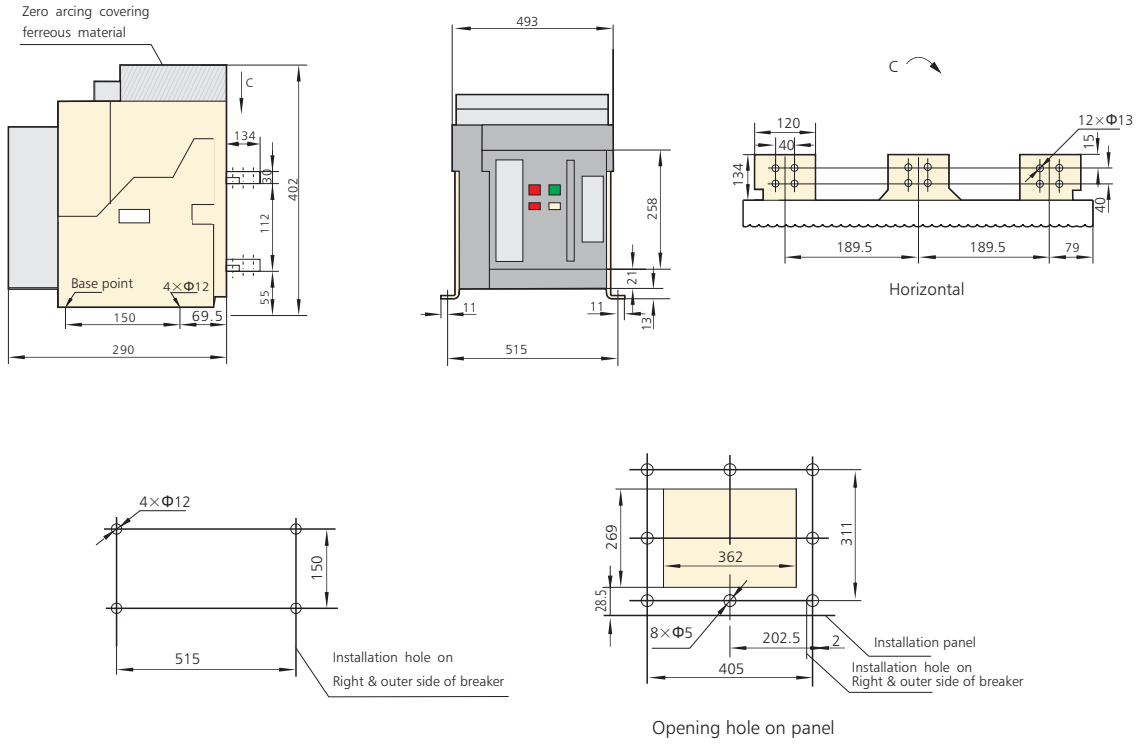

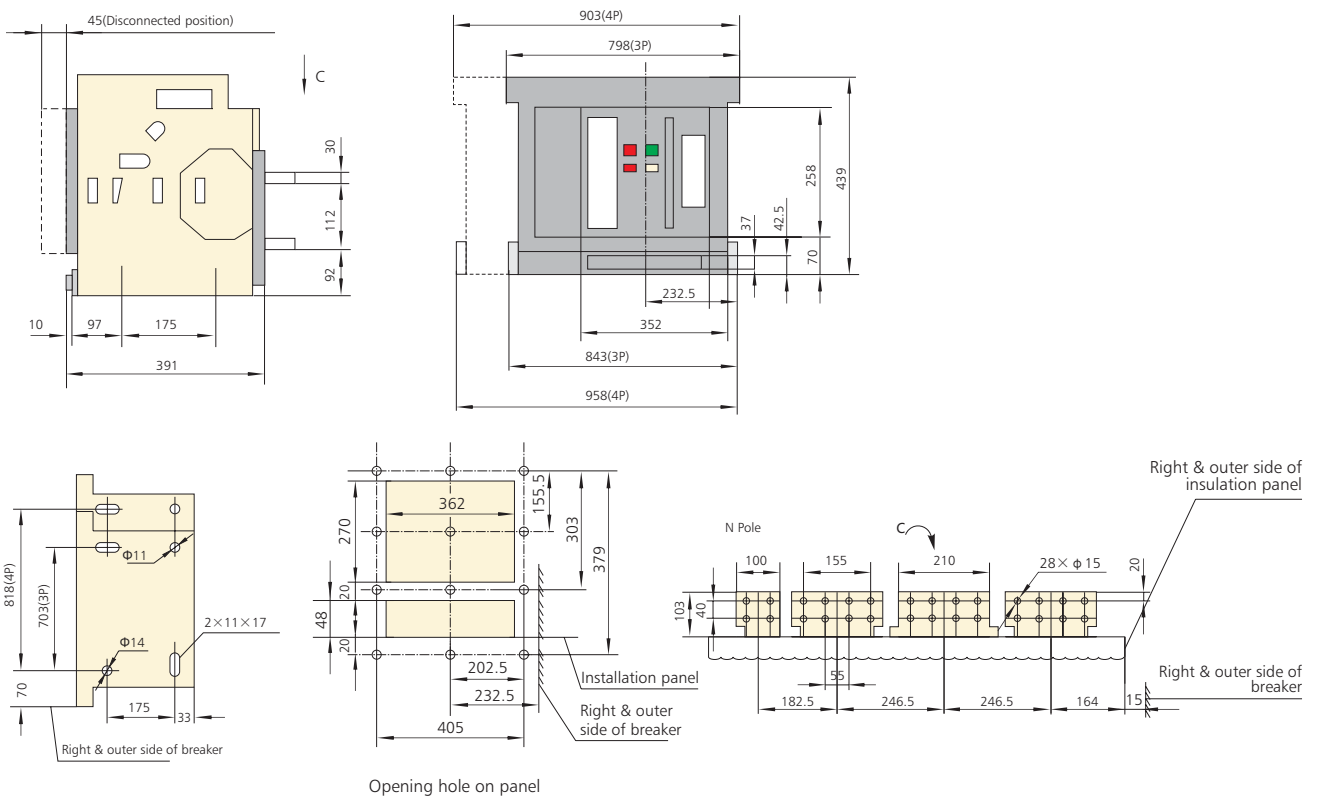
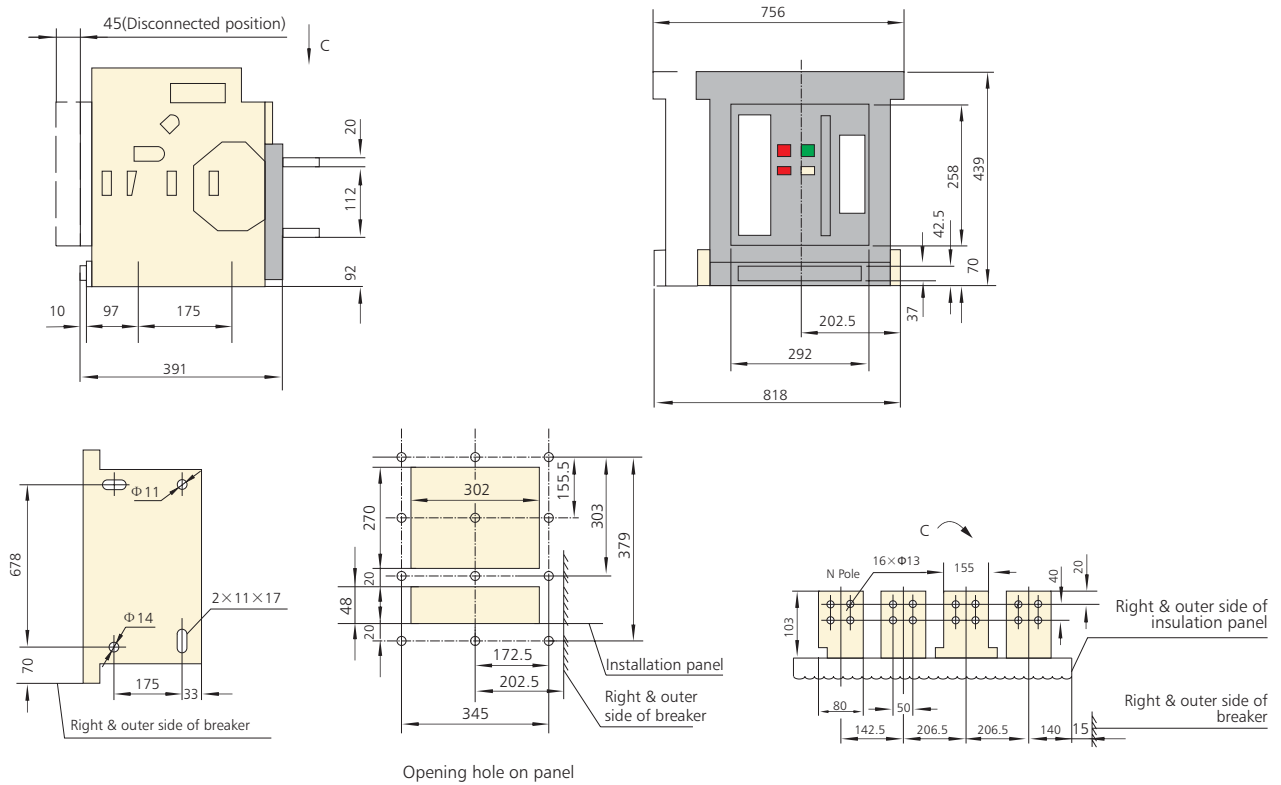

NA1-6300 (In=6300A) Drawout-type (3P)

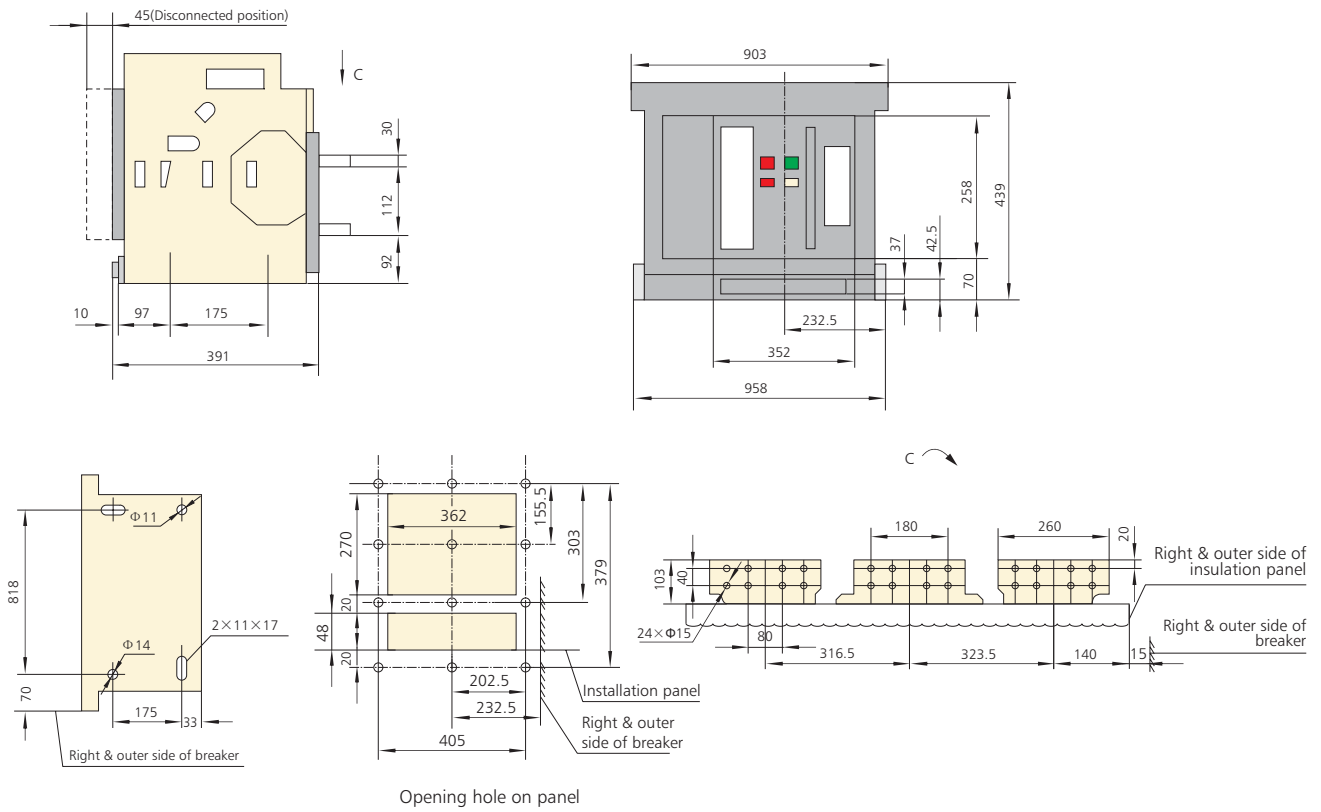

6. Secondary circuit wiring

6.1 NA1-1000

Standard type, type (M)

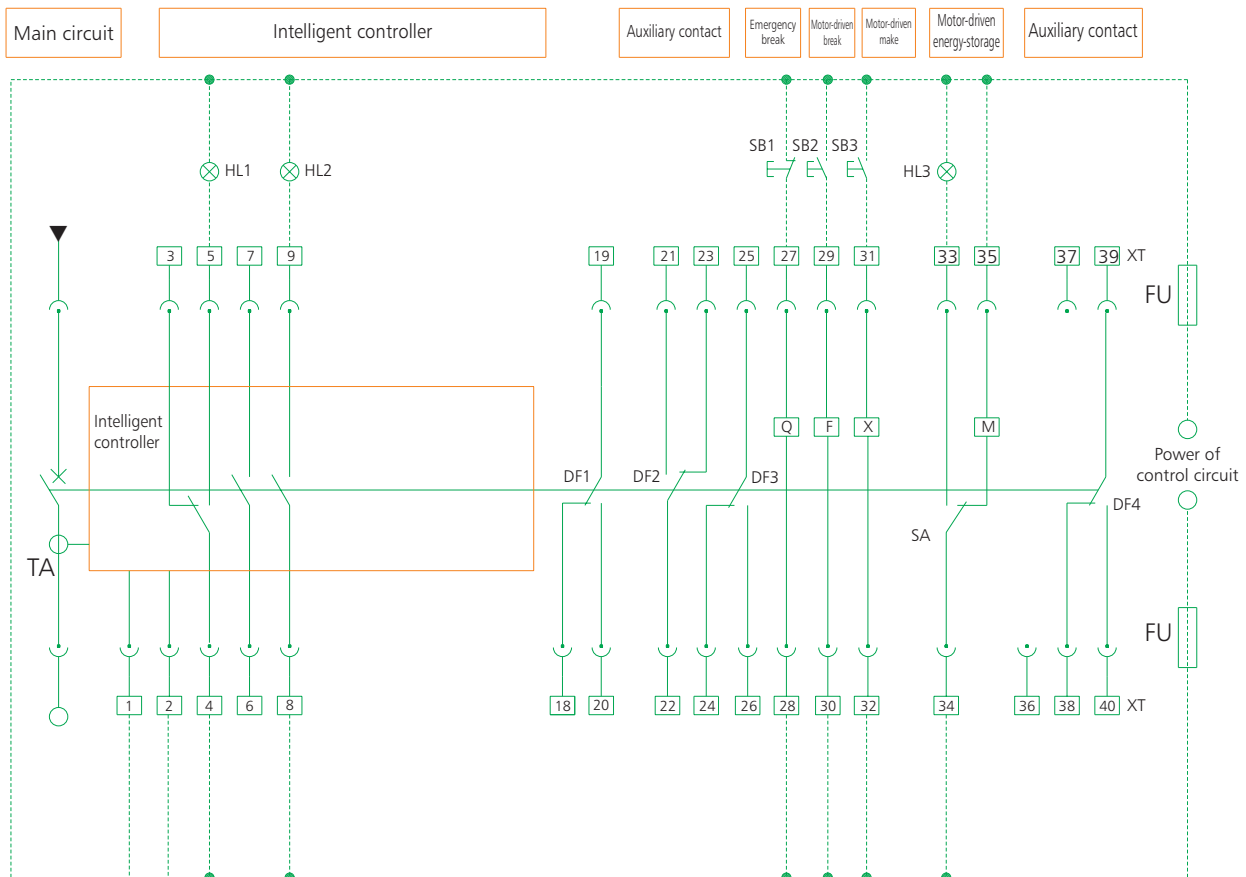

HL1: Failure indicator
 HL2: Close indicator
 HL3: Energy storage indicator
 SB1: Under-voltage button
 SB2: Shunt button
 SB3: Close button
 Q: Under-voltage release
 F: Shunt release
 X: Close electromagnet
 M: Energy storage motor
 DF1-DF4: Auxiliary switch
 1[#], 2[#]: Auxiliary power input
 3[#], 4[#], 5[#]: Fault trip contact output(4[#] common terminal, contact capacity AC230V,5A)
 6[#], 7[#]: To be connected with current transformer(selective)

8[#], 9[#]: Making indicator (capacity AC400V,1A)
 27[#], 28[#]: Under-voltage release
 29[#], 30[#]: Shunt release
 31[#], 32[#]: Closing electromagnet
 33[#], 34[#], 35[#]: Energy storage motor
 18[#]~26[#], 38[#]~40[#]: Auxiliary contact (auxiliary contact capacity: AC230V,5A)

Note:

Dashed is to be connected by users.

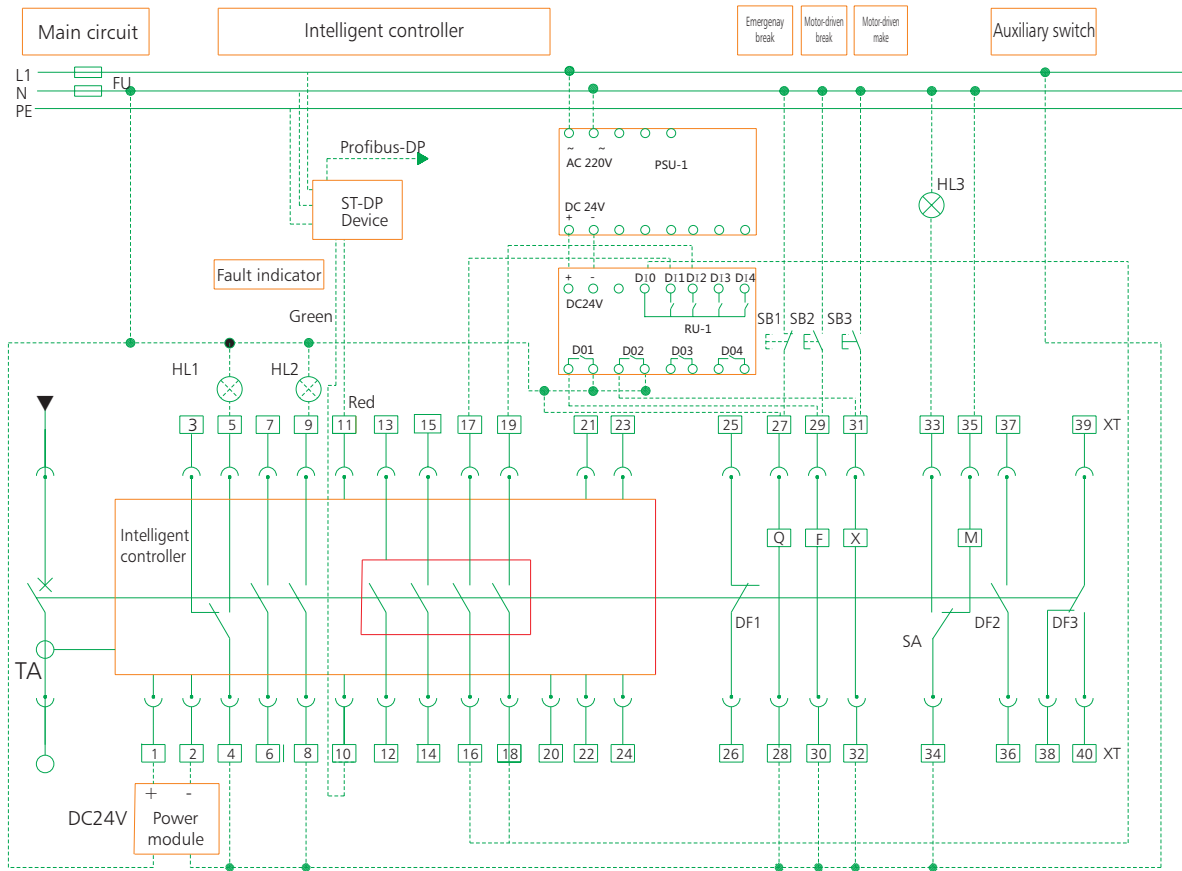

- HL1: Failure indicator
- HL2: Close indicator
- HL3: Energy storage indicator
- SB1: Under-voltage button
- SB2: Shunt button
- SB3: Close button
- Q: Under-voltage release
- F: Shunt release
- X: Close electromagnet
- M: Energy storage motor
- DF1-DF3: Auxiliary switch
- 1[#], 2[#]: Auxiliary power input(DC24)
- 3[#],4[#],5[#]: Fault trip contact output(4[#] common terminal, contact capacity AC230V,5A)
- 6[#], 7[#]: To be connected with current transformer(N/O auxiliary contact, capacity AC400V, 1A,when no current transformer)

- 8[#],9[#]: Making indicator(capacity AC400V,1A)
- 10[#], 11[#]: communication output
- 12[#], 13[#]: Signal alarm of load 1 output
- 14[#], 15[#]: Signal alarm of load 2 output
- 16[#], 17[#]: Making signal output
- 18[#], 19[#]: Closing signal output
- 20[#]: Communication shield ground line
- 21[#]~24[#]: Voltage signal input of phase N,A,B,C
- 25[#], 26[#]: Auxiliary contact (capacity:AC230V,5A)
- 27[#],28[#]: Under-voltage release
- 29[#],30[#]: Shunt release
- 31[#],32[#]: Closing electromagnet
- 33[#],34[#],35[#]: Energy storage motor
- 36[#]~40[#]: Auxiliary contact (capacity:AC230V,5A)

Note:

Dashed is to be connected by users.

3NO(normal open) 3NC (normal close) standard type (M)

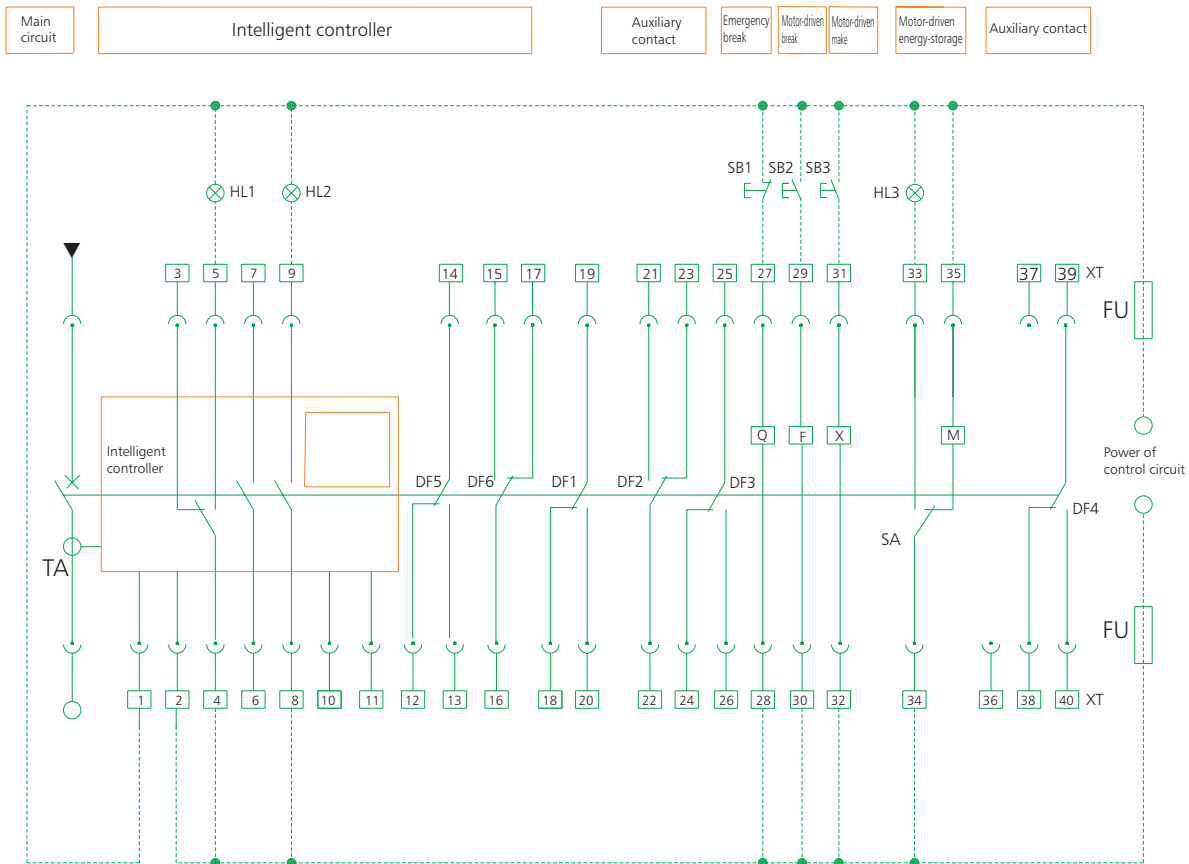

- HL1: Failure indicator
- HL2: Close indicator
- HL3: Energy storage indicator
- SB1: Under-voltage button
- SB2: Shunt button
- SB3: Close button
- Q: Under-voltage release
- F: Shunt release
- X: Close release
- M: Energy storage motor
- DF1-DF6: Auxiliary switch
- 1[#], 2[#]: Auxiliary power input
- 3[#], 4[#], 5[#]: Fault trip contact output(4[#] common terminal, contact capacity AC230V,5A
- 6[#], 7[#]: to be connected with current transformer(selective)

- 8[#], 9[#]: Making indicator (capacity AC400V,1A)
- 12[#]~26[#]: Auxiliary contact(auxiliary contact capacity: AC230V,5A)
- 27[#], 28[#]: Under-voltage release
- 29[#], 30[#]: Shunt release
- 31[#], 32[#]: Closing release
- 33[#], 34[#]: Energy storage indicator
- 34[#], 35[#]: Energy storage motor
- 38[#]~40[#]: Auxiliary contact(auxiliary contact capacity: AC230V,5A)

Note:

6NO(normal open) 6NC(normal close), without any additional function.
Dashed is to be connected by users.

6.2 NA1-2000~6300

The secondary circuit wiring for NA1-2000~6300 with standard type (M) intelligent controller and instantaneous under-voltage release

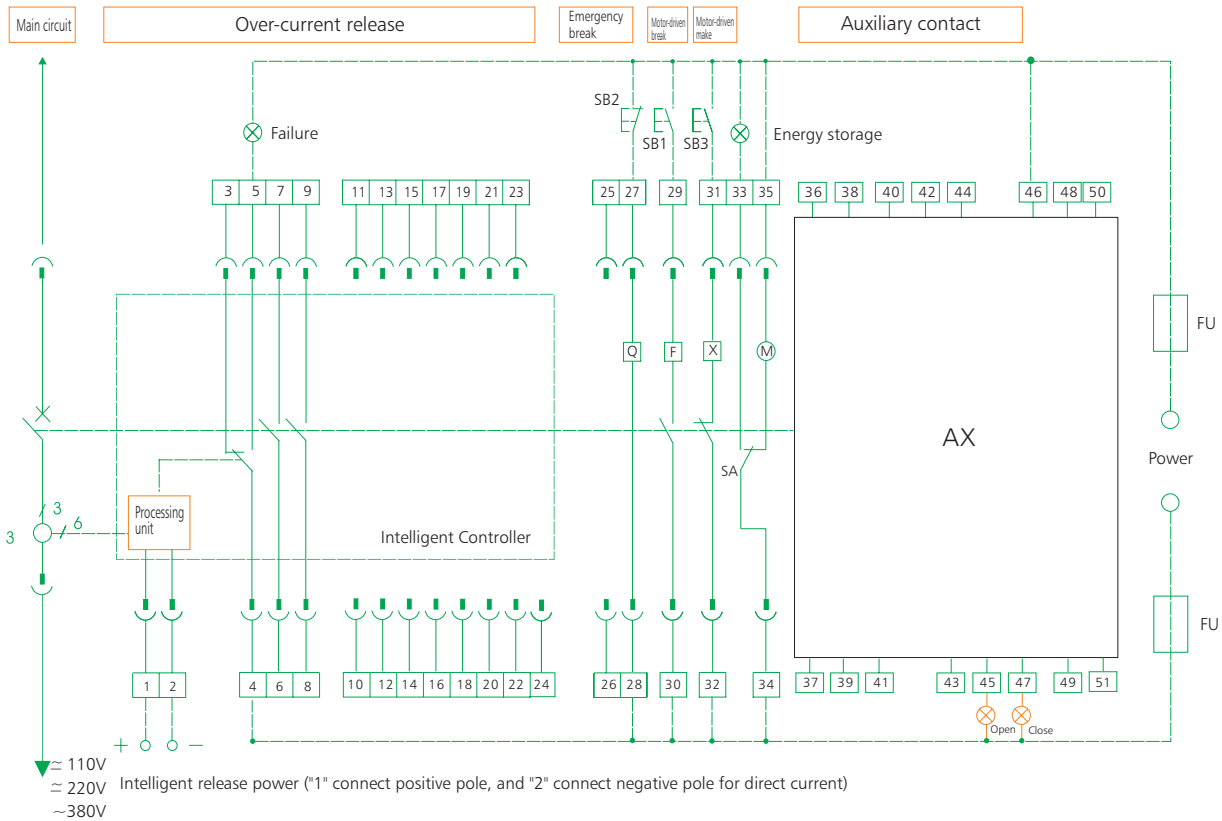

- SB1: Shunt button
- SB2: Under-voltage button
- SB3: Making button
- Q: Under-voltage release
- F: Shunt release
- X: Closing electromagnet
- M: Energy storage motor
- XT: Connection terminal
- SA: Position switch

Note: If control voltage of Q, F, X is different from each other, they can be connected to different power.

- 1[#], 2[#]: Auxiliary power input
- 3[#], 4[#], 5[#]: Fault trip contact output(4[#] common terminal)
- 6[#], 7[#], 8[#], 9[#]: Auxiliary contact, normal open,
- 10[#]~24[#]: empty
- 25[#], 26[#]: to be connected with current transformer(selective)
- 27[#], 28[#]: Under-voltage release
- 29[#], 30[#]: Shunt release
- 31[#], 32[#]: Closing release
- 33[#], 34[#]: Energy storage indicator
- 34[#], 35[#]: Energy storage motor
- 36[#], 51[#]: Auxiliary contact

The auxiliary contact modes for customer use

I Four switch contact (acquiescence)

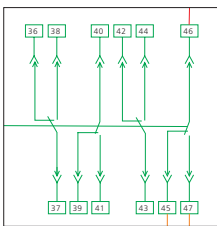

II Five switch contact

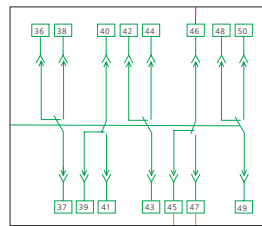

Circuit explanation for signal output:

- a. Broken-line parts shall be provided by customers.
- b. Terminals 6[#], 7[#] can output NC (normal close) contact if that is required by users.
- c. Terminal 35[#] can be directly connected to power (automatic pre-storing energy), alternatively connect power after connecting NO button (manual-controlled pre-storing energy).
- d. Terminals 21[#]~24[#] is only for wiring with function meter display. (excluding the special wiring)

The secondary circuit wiring for NA1-2000~6300 with type (3M) intelligent controller and instantaneous under-voltage release

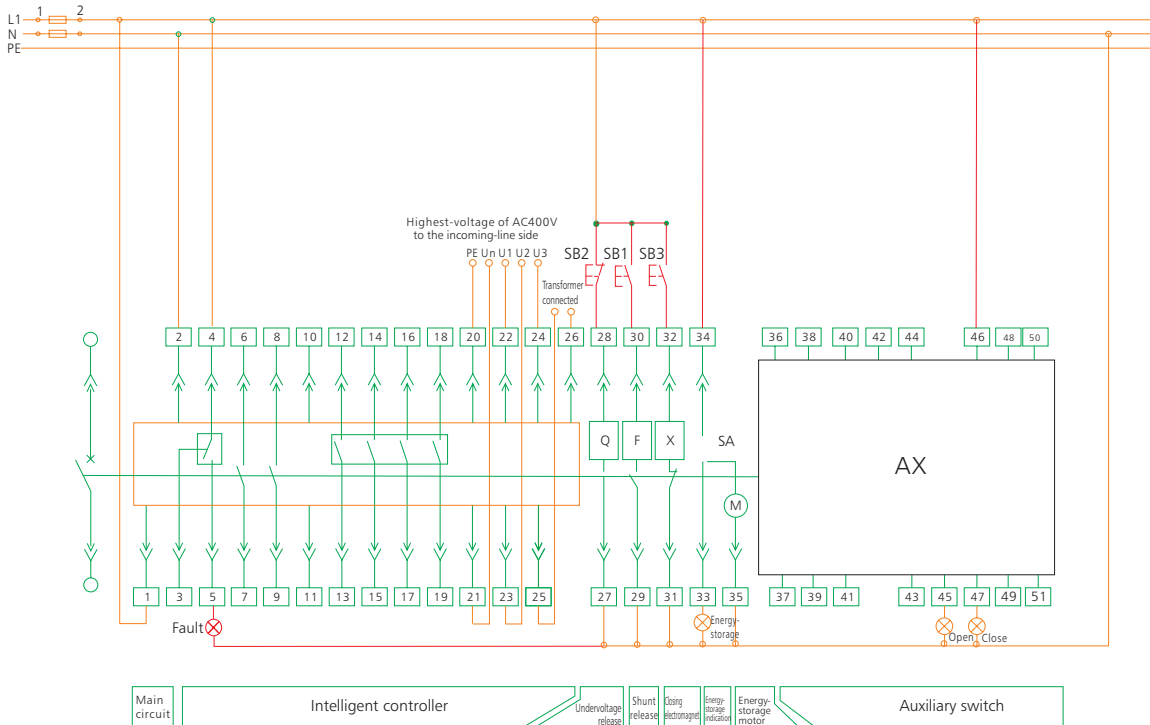

The auxiliary contact modes for customer use

I Four switch contact (acquiescence)

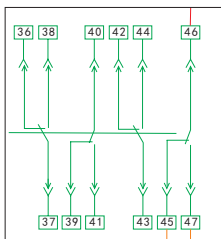

II Five switch contact

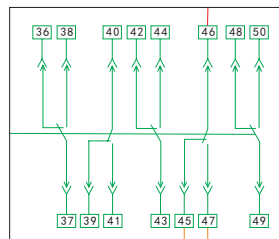

- SB1: Shunt button
- SB2: Under-voltage button
- SB3: Making button
- Q: Under-voltage release
- F: Shunt release
- X: Closing release
- M: Energy storage motor
- XT: connection terminal
- SA: Position switch

1#, 2#: Intelligent controller power input

Note: When the power supply of the intelligent controller is AC power, the 1#~2# connects to the AC power directly. When the power supply is DC power, forbid connecting the 1#~2# to the DC power directly. Add a DC power supply module, then the DC power connect to the input terminal of the DC power supply module, and the 1#~2# connect to the output terminal of the DC power supply module, or else the intelligent controller will be damaged.

3#, 4#, 5#: Fault trip contact output(4# common terminal)

6#, 7#, 8#, 9#: Auxiliary contact(normal open)

10#~11#: empty

12#~19#: The programmable output terminal. The normal products without these terminals, but if the customer special ordered, the cost extra added.

3M type acquiescence output:

12#, 13#: Signal alarm of load 1 output; 14#, 15#: Signal alarm of load2 output

16#, 17#: Self-diagnose alarm; 18#, 19#: Fault trip; 20#: PE line; 21#~24#: Display the voltage of the signal input.

The normal products without these terminals,

if the customer special ordered the function meter, the cost extra added.

21#: N phase input terminal

22#, 23#, 24#: A, B, C three phase power input terminal (note the sequence)(highest-voltage of AC 400V)

25#, 26#: Connect to the N phase current transformer or the input terminal of the current leakage transformer.

The normal products without these terminals, if the customer special ordered, the cost extra added.

27#, 28#: Under-voltage release; 29#, 30#: Shunt release; 31#, 32#: Closing release; 33#, 34#: Energy storage indicator

34#, 35#: Energy storage motor; 36#~51#: Auxiliary contact

Note:

a. Red colored part is to be connected by users

b. When the power system is three phase three wire, directly connect the Un to U2.

(If the voltage exceeds 400V, special explanation when ordered)

The secondary circuit wiring for NA1-2000~6300 with type (3H) intelligent controller and instantaneous under-voltage release

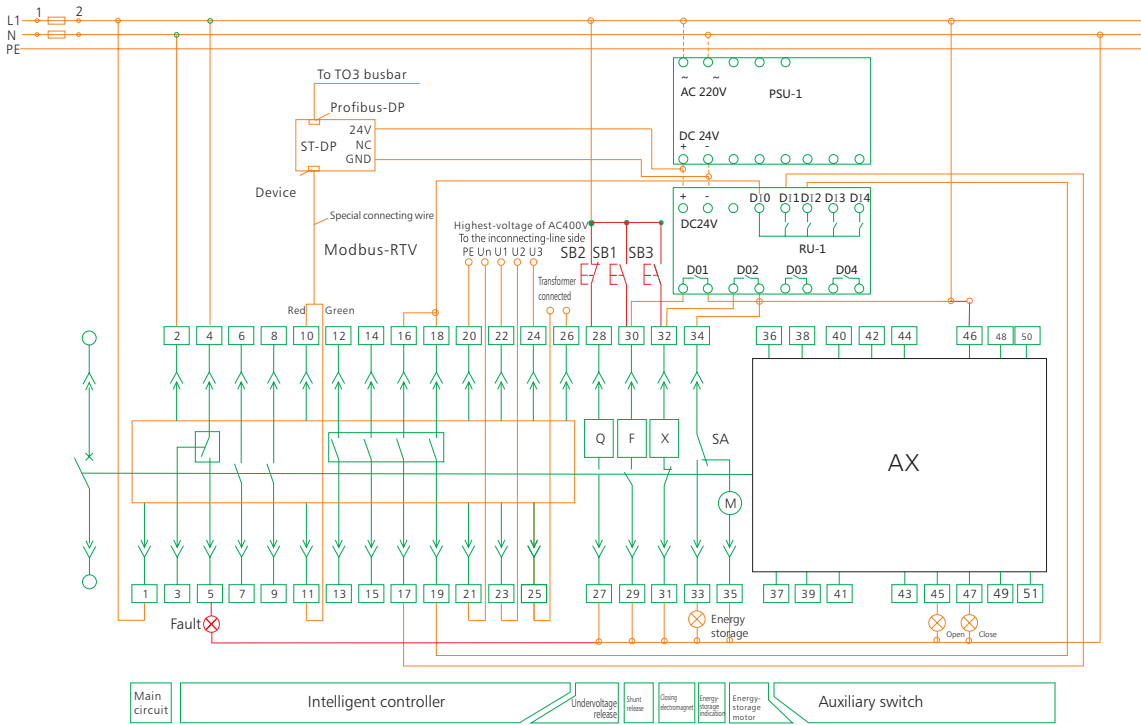

The auxiliary contact modes for customer use

I Four switch contact (acquiescence) **II** Five switch contact

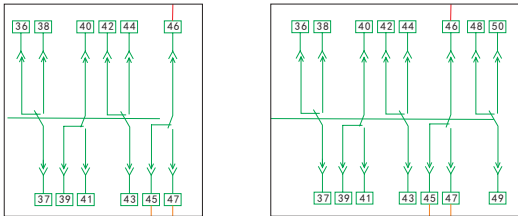

- 3[#],4[#],5[#]: Fault trip contact output(4[#] common terminal)
- 6[#],7[#],8[#],9[#]: Auxiliary contact (normal open)
- 10[#]~11[#]: communication output
- 12[#],13[#]: Signal alarm of load 1 output; 14[#],15[#]: Signal alarm of load2 output
- 16[#],17[#]:Breaking signal output; 18[#],19[#]:Making signal output
- 20[#]: PE line; 21[#]: N phase input terminal
- 22[#],23[#],24[#]: A, B, C three phase power input terminal (note the sequence)(highest-voltage of AC 400V)

25[#]26[#]: Connect to the N phase current transformer or the input terminal of the current leakage transformer. The normal products without these terminals, if the customer special ordered, the cost extra added.

ST~DP: DP protocol module. There is no need for the ST-DP protocol module, if the communication protocol is Modbus-RTV. But when the communication protocol is Profibus-DP, the ST-DP protocol module is necessary, but the cost extra added.

ST power module IV: power converter (optional components)

ST201: Magnify the signal capacity of the controller. (optional components) If the customer special ordered, the cost extra added.

- 27[#],28[#]: Under-voltage release; 29[#],30[#]: Shunt release
- 31[#],32[#]: Closing release; 33[#],34[#]: Energy storage indicator
- 34[#],35[#]: Energy storage motor; 36[#]~51[#]: Auxiliary contact

Note:

- a. Red colored part is to be connected by users
- b. When the power system is three phase three wire, directly connect the Un to U2. (If the voltage exceeds 400V, special explanation when ordered)

- SB1: Shunt button; SB2: Under-voltage button
- SB3: Making button; Q: Under-voltage release
- F: Shunt release; X: Closing release
- M: Energy storage motor; XT: connection terminal
- SA: Position switch

1[#], 2[#]: Intelligent controller power input

Note: When the power supply of the intelligent controller is AC power, the 1[#]~2[#] connects to the AC power directly. When the power supply is DC power, forbid connecting the 1[#]~2[#] to the DC power directly. Add a DC power supply module, then the DC power connect to the input terminal of the DC power supply module, and the 1[#]~2[#] connect to the output terminal of the DC power supply module, or else the intelligent controller will be damaged.

The secondary circuit wiring for NA1-2000~6300 with standard type (M) intelligent controller and time-delay under-voltage release

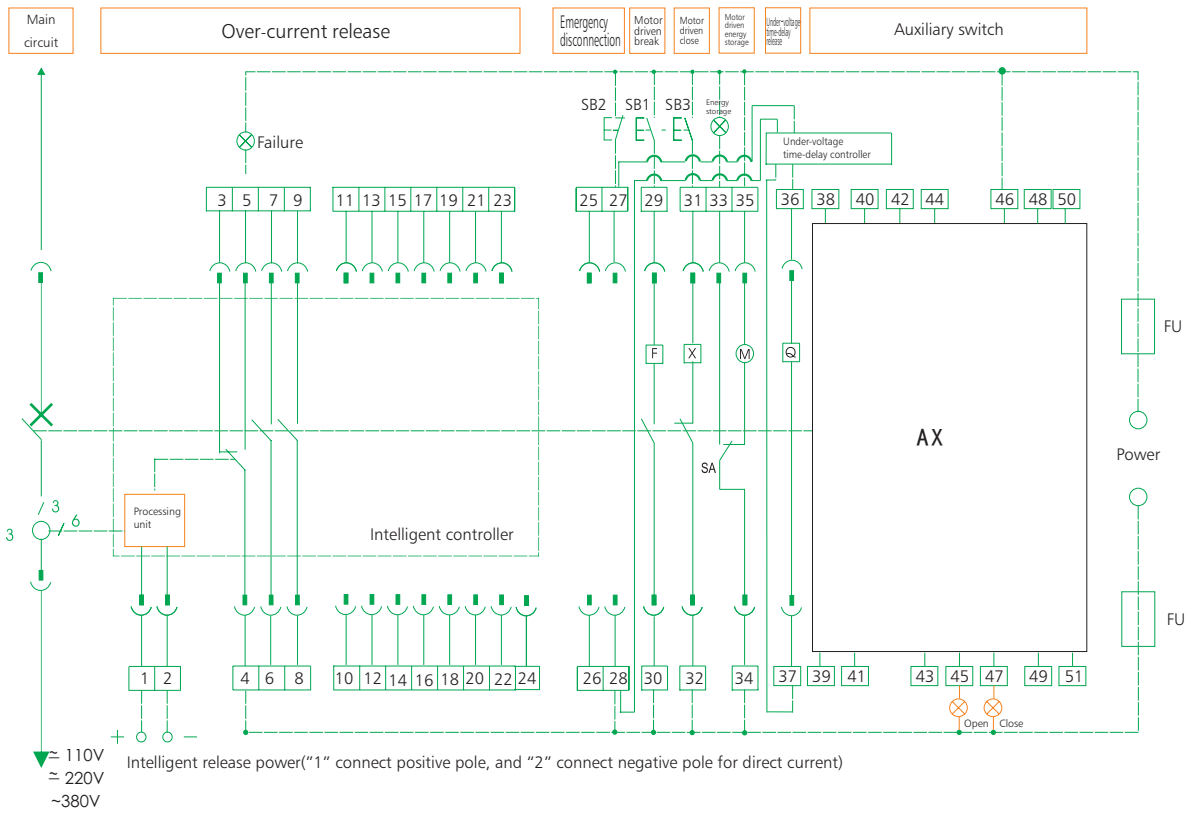

The auxiliary contact modes for customer use

I Four switch contact (acquiescence)

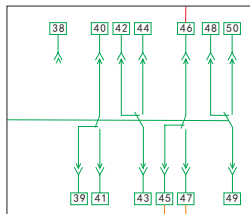

SB1: Shunt button SB2: Under-voltage button SB3: Making button
Q: Under-voltage time-delay release F: Shunt release
X: Closing electromagnet M: Energy storage motor
XT: Connection terminal SA: Position switch
Note: If control voltage of Q, F, X is different from each other, they can be connected to different power.

- 1[#], 2[#]: Auxiliary power input
- 3[#], 4[#], 5[#]: Fault trip contact output(4# common terminal)
- 6[#], 7[#], 8[#], 9[#]: Auxiliary contact (normal open)
- 10[#]~24[#]: empty
- 25[#], 26[#]: to be connected with current transformer(selective)
- 27[#], 28[#]: Under-voltage release
- 29[#], 30[#]: Shunt release
- 31[#], 32[#]: Closing release
- 33[#], 34[#]: Energy storage indicator
- 34[#], 35[#]: Energy storage motor
- 36[#], 37[#]: Under-voltage time delay release
- 38[#]~51[#]: Auxiliary contact

Circuit explanation for signal output:

- a. Broken-line parts shall be provided by customers.
- b. Terminals 6[#], 7[#] can output NC (normal close) contact if that is required by users.
- c. Terminal 35[#] can be directly connected to power (automatic pre-storing energy), alternatively connect power after connecting NO button (manual-controlled pre-storing energy).
- d. The 21[#]~24[#] is only for wiring with function meter display. (Excluding the special wiring)

The secondary circuit wiring for NA1-2000~6300 with type (3M) intelligent controller and time-delay under-voltage release

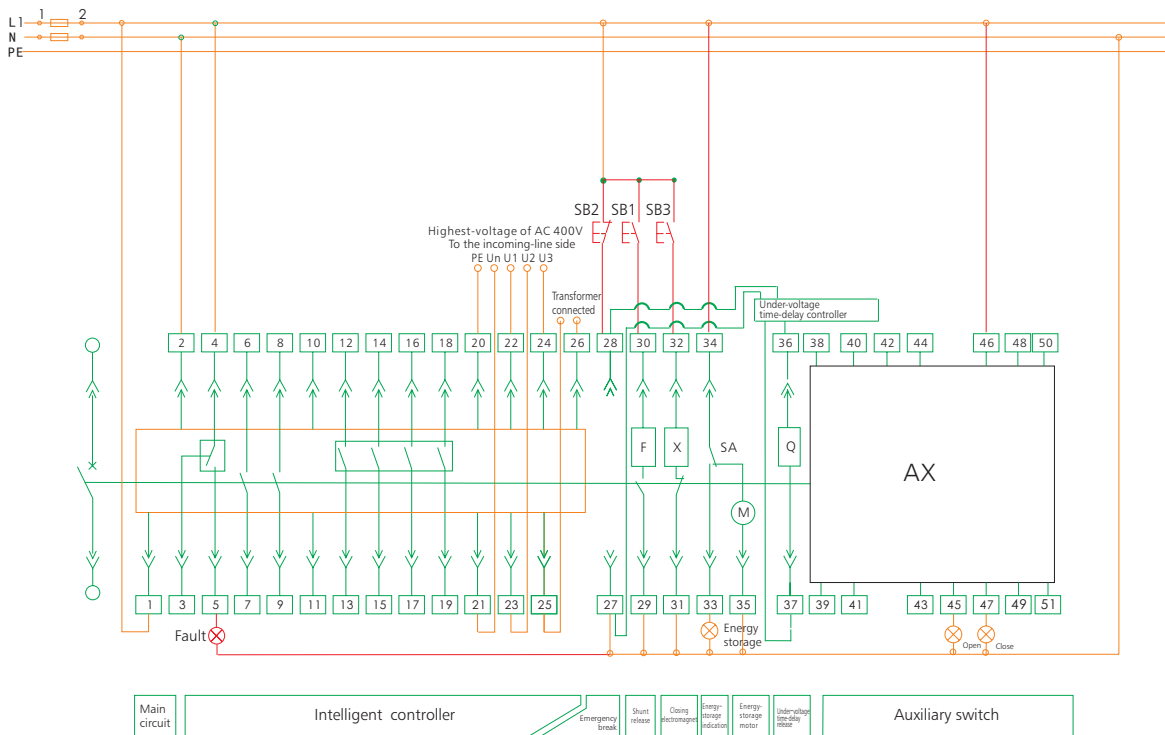

The auxiliary contact modes for customer use

I Four switch contact (acquiescence)

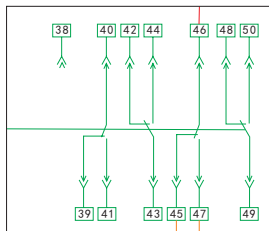

SB1: Shunt button; SB2: Under-voltage button

SB3: Making button; Q: Under-voltage release

F: Shunt release; X: Closing release

M: Energy storage motor; XT: Connection terminal

SA: Position switch

1#, 2#: Intelligent controller power input

Note: When the power supply of the intelligent controller is AC power, the 1#~2# connects to the AC power directly. When the power supply is DC power, forbid connecting the 1#~2# to the DC power directly. Add a DC power supply module, then the DC power connect to the input terminal of the DC power supply module, and the 1#~2# connect to the output terminal of the DC power supply module, or else the intelligent controller will be damaged.

3#,4#,5#: Fault trip contact output(4# common terminal); 6#,7#,8#,9#: Auxiliary contact (normal open)

10#~11#: empty; 12#~19# are the programmable output terminal. The normal products without these terminals, but if the customer special ordered, the cost extra added.

3M type acquiescence output:

12#,13#: Signal alarm of load 1 output; 14#,15#: Signal alarm of load2 output

16#,17#: Self-diagnose alarm; 18#,19#: Fault trip

20#: PE line; 21#~24#: Display the voltage of the signal input. The normal products without these terminals, if the customer special ordered the function meter, the cost extra added.

21#: N phase input terminal; 22#,23#,24#: A, B, C three phase power input terminal (note the sequence)(Highest-voltage of AC400V)

25#,26# Connect to the N phase current transformer or the input terminal of the current leakage transformer.

The normal products without these terminals, if the customer special ordered, the cost extra added.

27#,28#: Under-voltage release; 29#,30#: Shunt release

31#,32#: Closing release; 33#,34#: Energy storage indicator

34#,35#: Energy storage motor; 36#,37#: Under-voltage time delay release

38#~51#: Auxiliary contact

Note:

a. Red colored part is to be connected by users

b. When the power system is three phase three wire, directly connect the Un to U2. (If the voltage exceeds 400V, special explanation when ordered)

The secondary circuit wiring for NA1-2000~6300 with type (3H) intelligent controller and time-delay under-voltage release

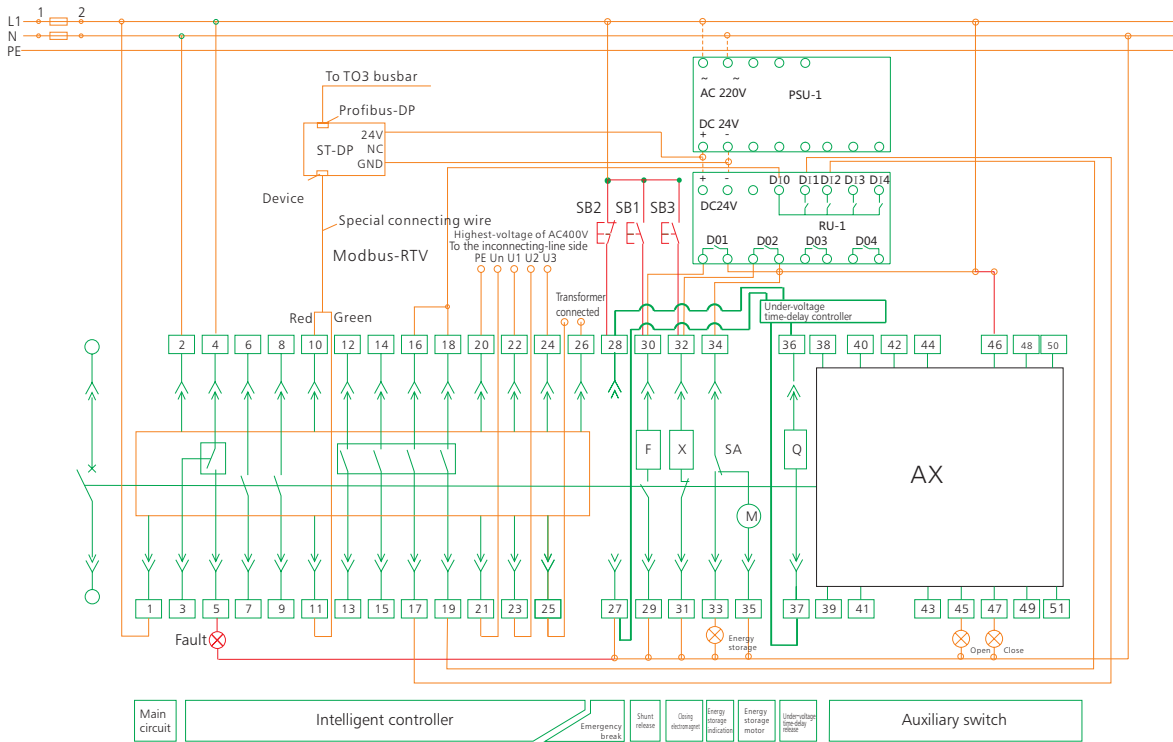

The auxiliary contact modes for customer use

I Four switch contact (acquiescence)

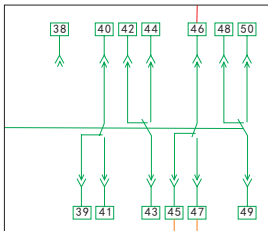

3[#],4[#],5[#]: Fault trip contact output(4[#] common terminal)

6[#],7[#],8[#],9[#]: Auxiliary contact (normal open)

10[#]~11[#]: Communication output; 12[#],13[#]: Signal alarm of load 1 output

14[#],15[#]: Signal alarm of load 2 output; 16[#],17[#]: Breaking signal output; 18[#],19[#]: Closing signal output

20[#]: PE line; 21[#]: N phase input terminal

22[#],23[#],24[#]: A, B, C three phase power input terminal (note the sequence)(highest-voltage of AC400V)

25[#],26[#] Connect to the N phase current transformer or the input terminal of the current leakage transformer.

The normal products without these terminals, if the customer special ordered, the cost extra added.

ST~DP: DP protocol module. There is no need for the ST-DP protocol module,

if the communication protocol is Modbus-RTV. But when the communication protocol is Profibus-DP,

the ST-DP protocol module is necessary, but the cost extra added.

ST power module IV: power converter (optional components)

ST201: Magnify the signal capacity of the controller. (optional components)

If the customer special ordered, the cost extra added.

27[#],28[#]: Under-voltage release; 29[#],30[#]: Shunt release

31[#],32[#]: Closing release; 33[#],34[#]: Energy storage indicator

34[#],35[#]: Energy storage motor; 36[#],37[#]: Under-voltage time delay release

38[#]~51[#]: Auxiliary contact

SB1: Shunt button; SB2: Under-voltage button

SB3: Making button; Q: Under-voltage release

F: Shunt release; X: Closing release

M: Energy storage motor; XT: Connection terminal

SA: Position switch

1[#], 2[#]: Intelligent controller power input

Note: When the power supply of the intelligent controller is AC power, the 1[#]~2[#] connects to the AC power directly.

When the power supply is DC power, forbid connecting the 1[#]~2[#] to the DC power directly. Add a DC power supply module, then the DC power connect to the input terminal of the DC power supply module, and the 1[#]~2[#] connect to the output terminal of the DC power supply module, or else the intelligent controller will be damaged.

Note:

a. Red colored part is to be connected by users

b. When the power system is three phase three wire, directly connect the Un to U2.

(If the voltage exceeds 400V, special explanation when ordered)

7. Installation

7.1 Installation

7.1.1 Unload the breaker from the soleplate of package. If it is drawout type, firstly pull out the handle under the drawer-base of breaker, and plug it into the hole on central part of plastic cover under the drawer-base crossbeam, anticlockwise turns the handle, the body will slowly slide along the outside of drawer-base.

When the guide rod points to separated position and handle can't be rotated any longer, pull out the handle and firmly grasp the aluminum handle on drawer-base, pull out the breaker body and remove it form the base, then move the base from the sole plate and clean up the dirty things inside the drawer-base.

Possible positions

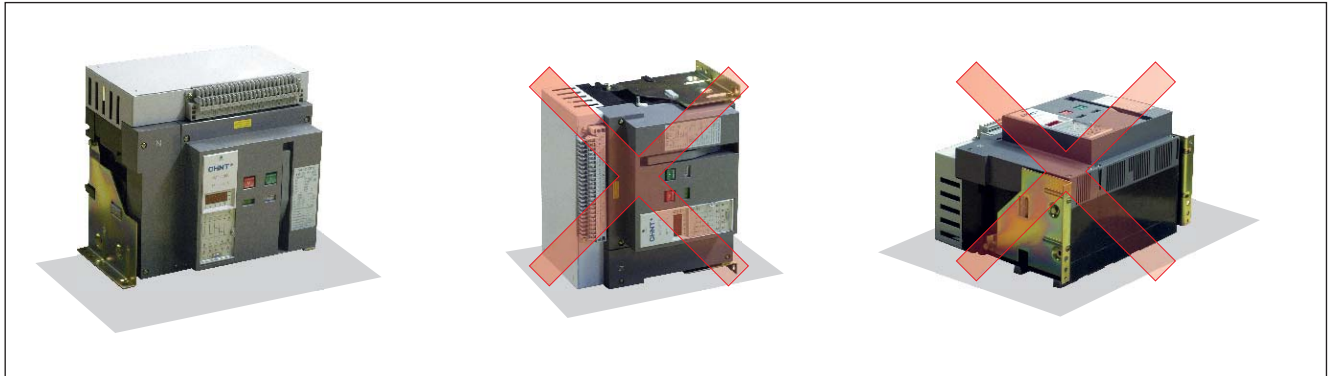

7.1.2 Check the insulation resistance with a 500V megger, resistance should not be less than 20MΩ when ambient temperature is 20℃±5℃ and relative humidity is 50%~70%. Otherwise dry it.

7.1.3 Power supply
NA1 devices can be supplied either from the top or from the bottom without reduction in performance, in order to facilitate connection when installed in a switchboard.

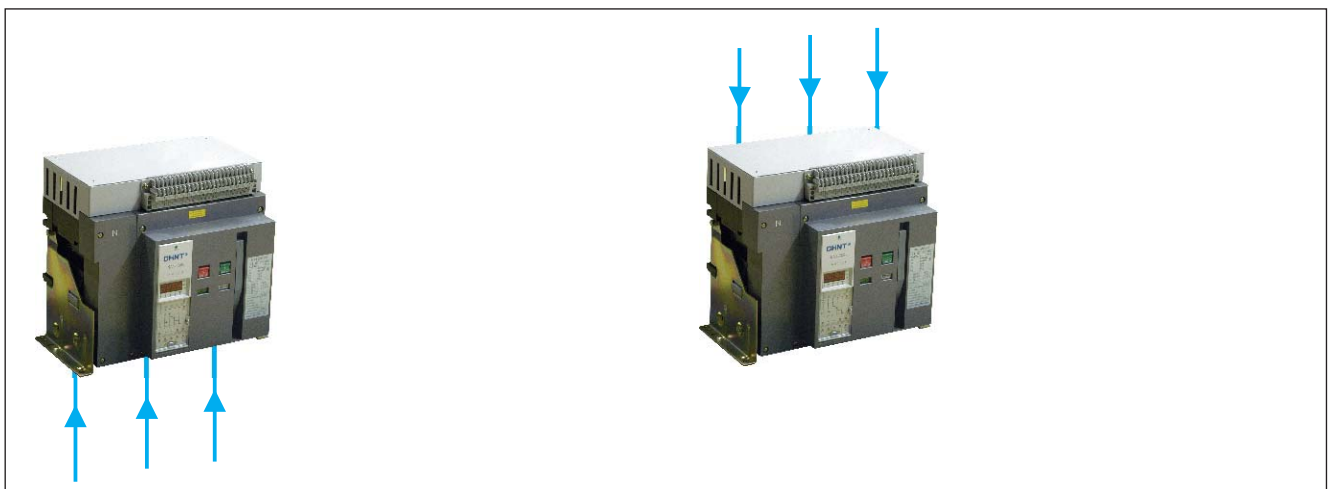

7.1.4 Put the breaker (fixed-type) or drawer-base (drawout-type) into the installation-bracket, and make it fixed, directly connect the cable wire of main circuit to the bus wire of fixed-type circuit breaker. Alternatively put breaker body onto the slideway of drawer-base. Plug the handle into installation hole, clockwise turns it until the under-part of drawer-base points at the connection position and "click" sound is heard. It indicates that breaker body has been connected to its place, then connect the cable of main circuit to drawer-base.

Mounting the circuit-breaker

It is important to distribute the weight of the device uniformly over a rigid mounting surface such as rails or a base plate.

This mounting plane should be perfectly flat (tolerance on support flatness: 2 mm). This eliminates any risk of deformation which could interfere with correct operation of the circuit breaker.

NA1 devices can also be mounted on a vertical plane using the special brackets.

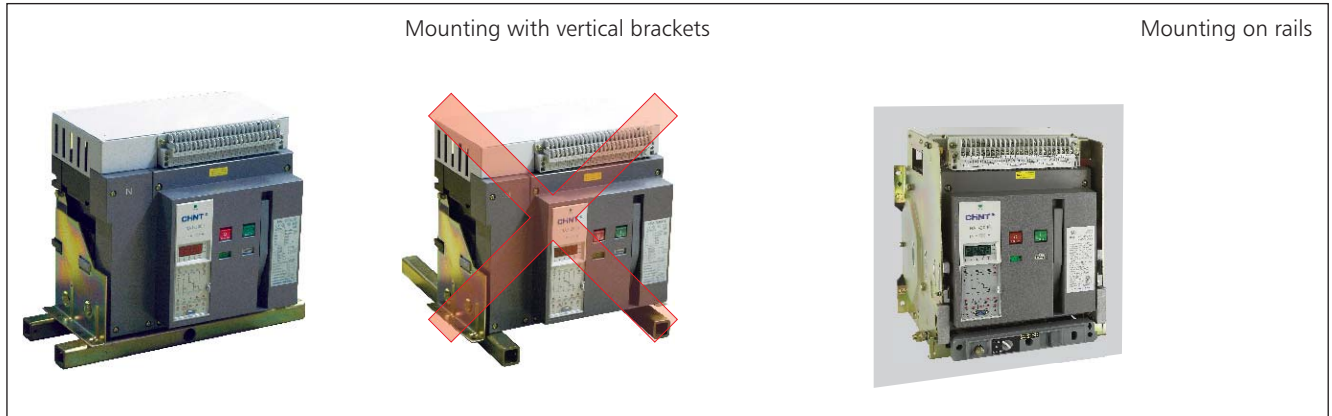

7.1.5 Partitions

Sufficient openings must be provided in partitions to ensure good air circulation around the circuit breaker; Any partition between upstream and downstream connections of the device must be made of nonmagnetic material. For high-currents, of 2500 A and upwards, the metal supports or barriers in the immediate vicinity of a conductor must be made of non-magnetic material A; Metal barriers through which a conductor passes must not form a magnetic loop.

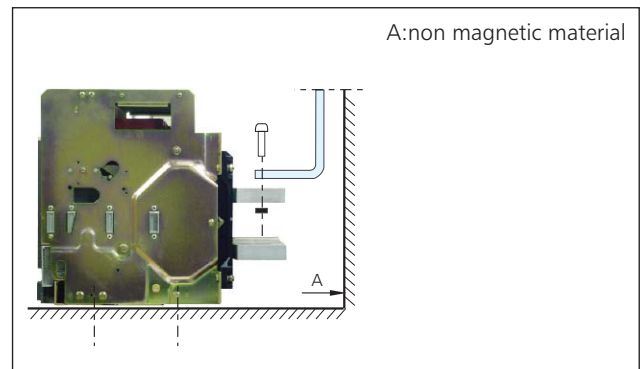

Busbars

The mechanical connection must exclude the possibility of formation of a magnetic loop around a conductor.

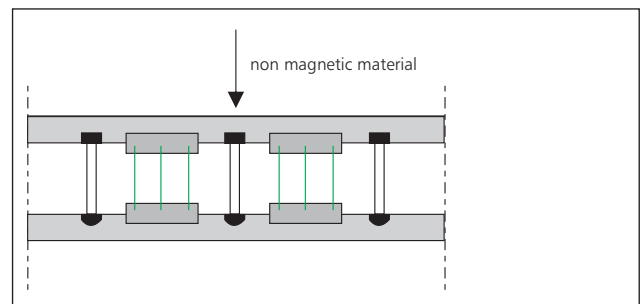

7.1.6 Busbar connections

The busbars should be suitably adjusted to ensure the connection points are positioned on the terminals before the bolts are inserted. The connections are held by the supporter which is fixed to the framework of the switchboard, in this way the circuit breaker terminals do not have to support its weight. (This supporter should be placed close to the terminals).

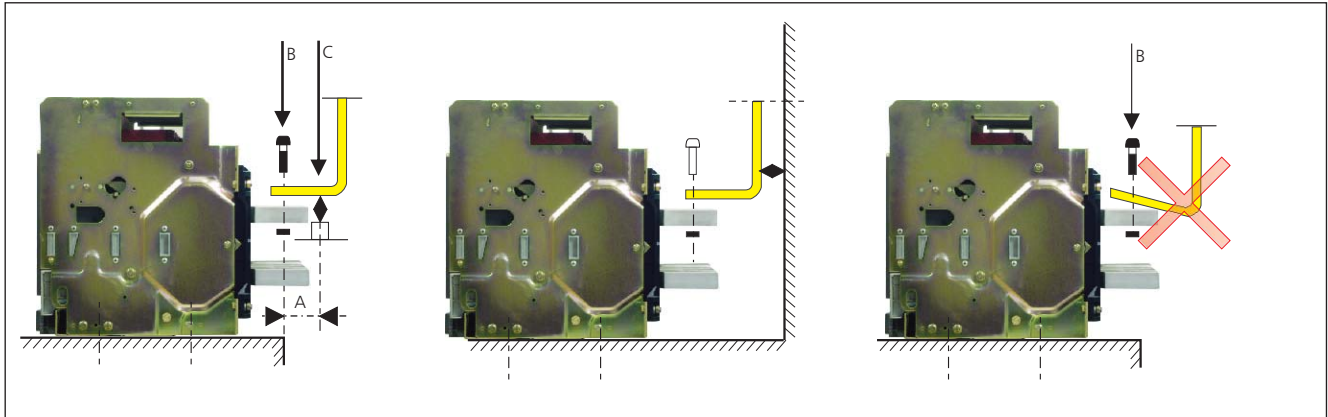

7.1.7 Main circuit adopts cable connection

Users should not apply too strong mechanical strength on the terminals of Air Circuit Breaker. Extend the bus-bar of circuit breaker with connecting bus-bar, position the wiring piece of cable before inserting bolts; the cable should be fixed on the frame of distributing cabinet firmly.

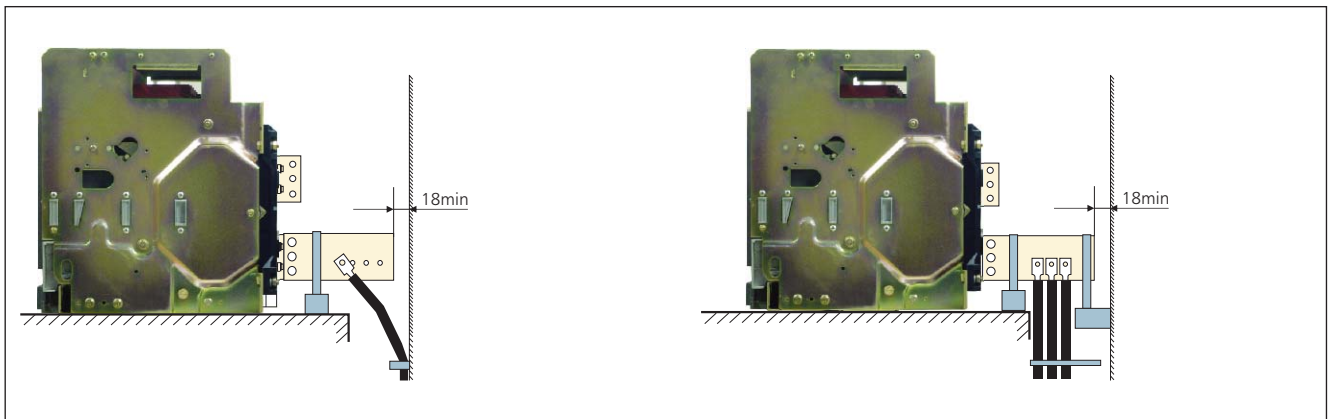

7.1.8 Clamping

Correct clamping of busbars depends on the tightening torques used for the nuts and bolts, etc. Over-tightening may have the same consequences as under-tightening.

For connecting busbars to the circuit breaker, the tightening torques to be used are shown in the table below. These values are for use with copper busbars and steel nuts and bolts, class 8.8.

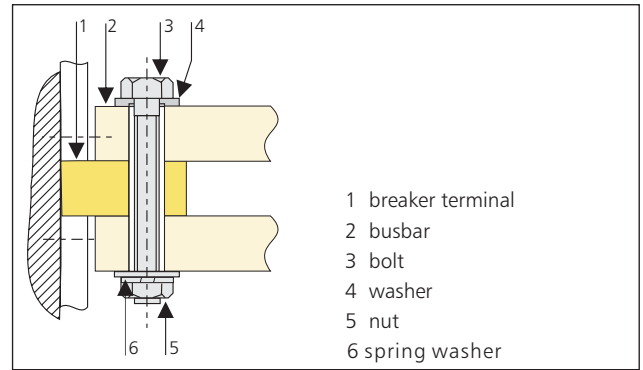

Examples

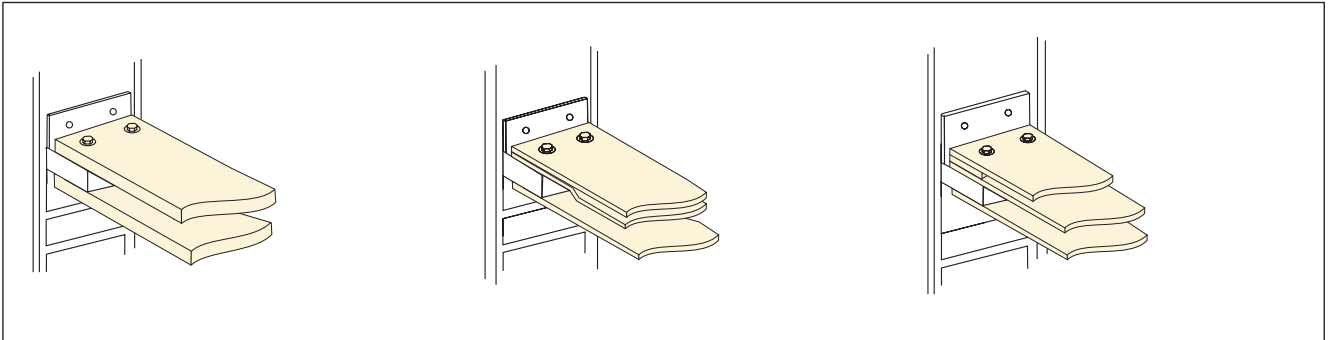

Preferred tightening torque for NA1's tightening components

Type of screw	Application	Preferred tightening torque
M4	Screws for secondary terminals	2.5–3.6 N·m
M10	Installing bolts of Air Circuit Breaker	38–55 N·m
M12	Connection terminals	61–94 N·m

Connected position



Test position



Disconnected position



Drawout position

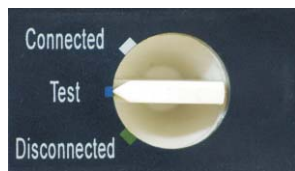
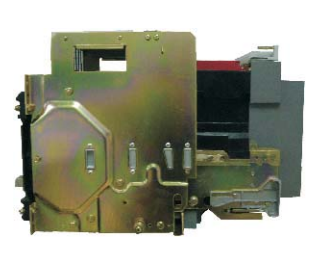

1. Both main circuit and control circuit are connected.
2. Normal application conditions

1. The main circuit is disconnected, and the control circuit is connected.
2. Test application conditions.

Neither the main circuit nor the control circuit is connected.

Main body is out of the drawer seat.

- 7.2 Wiring the secondary circuit according to electric principle diagram.
Note: Bolts, nuts, gaskets shouldn't be left inside the drawer seat to avoid being blocked.
- 7.3 Operation
Check the rated voltage of the following components whether conforms to the power voltage . Such as under voltage release, shunt release, closing electromagnet, motor-driven mechanism and intelligent controller.
- 7.4 Maintenance
Check the technical parameters in time or add some lubricating oil, etc.
This breaker structure is arranged vertically and modularized composition with each functioncell separated, which make the maintenance easy.
It has compact structure, reliable operation and strong free maintenance capability. Please check the technical parameters on the nameplate in accordance with the requirements of order before installation.

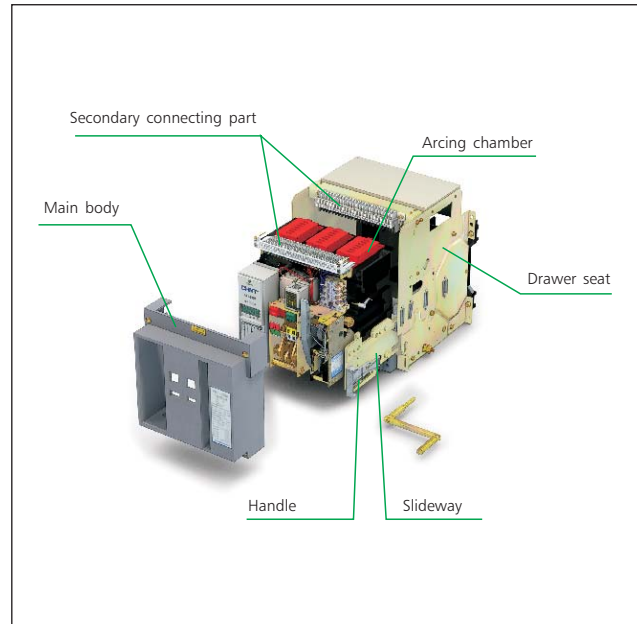

Making the secondary circuit power, the motor-driven mechanism can store energy automatically until hearing the click and energy stored indicating on the panel.

Otherwise press the storage handle for 6 times until hearing the click and the indicator display energy stored

And the closing operation can be realized either by closing electromagnet or manual button.

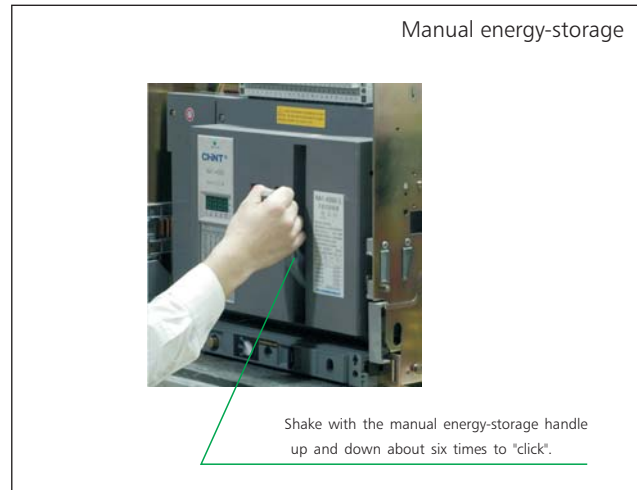

8. Recommendation for user's connecting bus-bar

Inm(A)		NA1-1000					NA1-2000					NA1-3200			NA1-4000		NA1-6300			
In(A)		200	400	630	800	1000	630	800	1000	1250	1600	2000	2000	2500	3200	4000/3P	4000/4P	4000	5000	6300
Busbar	Thickness(mm)	5	5	5	6	8	5	6	8	10	12	10	8	10	10	10	10	10	10	10
	Width(mm)	30	30	40	50	50	60	60	60	60	60	60	100	100	100	120	120	100	100	100
	Number	1	2	2	2	2	2	2	2	2	2	3	2	2	4	4	4	5	7	8

Note: the specifications in the table is obtained as the ambient temperature of air circuit breaker is 40°C, with open installation; this is in compliance with the specification of copper busbars adopted under the heating conditions regulated in IEC/EN60947-2.

9. Power loss

Inm(A)		NA1-1000					NA1-2000					NA1-3200			NA1-4000		NA1-6300			
In(A)		200	400	630	800	1000	630	800	1000	1250	1600	2000	2000	2500	3200	4000/3P	4000/4P	4000	5000	6300
Power loss (W)	Drawer type	40	101	123	110	171	70	110	172	268	440	530	384	600	737	921	900	575	898	1426
	Fixed type	33	85	107	94	146	34.4	50	78	122	200	262	200	312	307	450	-	-	-	-

10. A²S curve

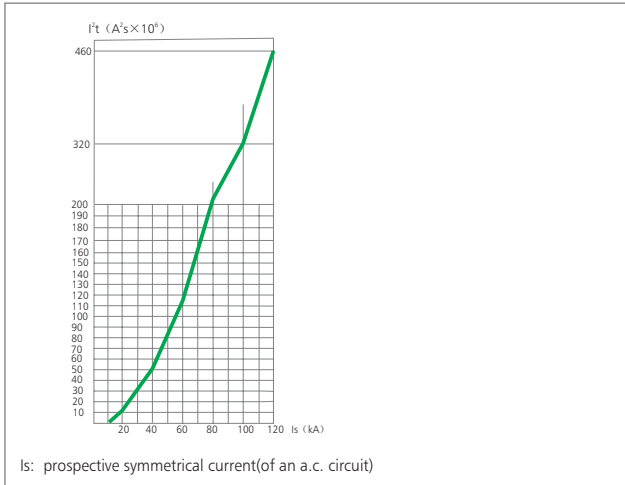

11. Temperature compensation correction

Standard	Ambient temperature	NA1-1000					NA1-2000					NA1-3200 NA1-4000			NA1-6300				
		40°C	200	400	630	800	1000	630	800	1000	1250	1600	2000	2000	2500	3200	4000	4000	5000
IEC/EN60947-2	45°C	195	395	623	790	985	630	800	1000	1250	1600	1900	2000	2400	3000	3800	4000	5000	6000
	50°C	192	384	605	768	960	630	800	1000	1250	1500	1900	2000	2300	3000	3600	4000	5000	5600
	55°C	182	328	584	725	924	630	800	1000	1200	1500	1800	2000	2200	2800	3400	4000	4800	5400
	60°C	174	248	548	696	870	610	800	1000	1150	1300	1700	2000	2200	2800	3200	4000	4800	5200
	65°C	163	192	500	620	810	610	800	1000	1150	1300	1650	2000	2200	2600	3200	4000	4800	5100
	70°C	150	170	473	600	750	473	640	750	938	1200	1400	1760	2000	2208	2520	3480	4000	4221

Note: The ACB is to calibrated at 40°C, special application please refer to the table above and the curve below.

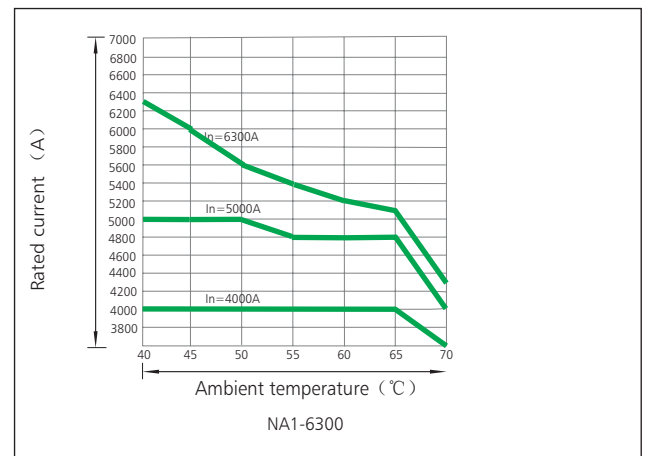
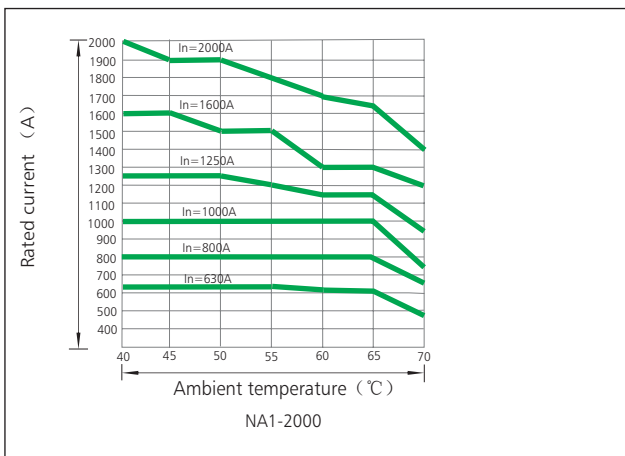
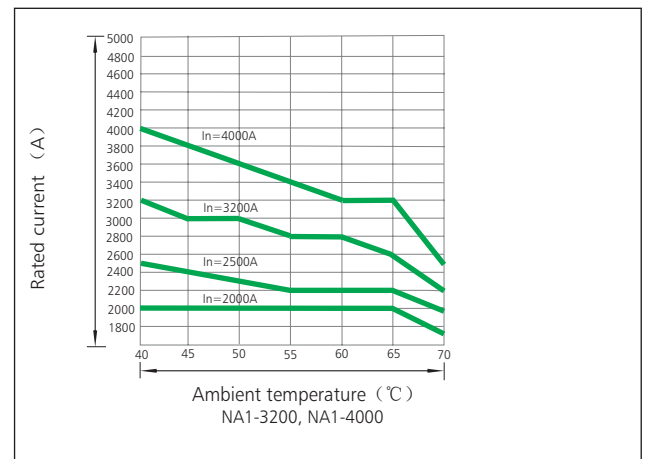
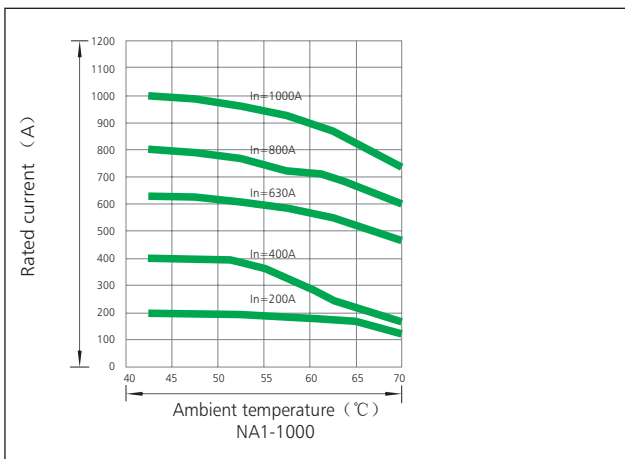

12. Coordination recommendations

Capacity of transformer (kVA) & parallelly connected number	Rated current of transformer In(A)	Short circuit current of main circuit (kA)	Breaking capacity of air circuit breaker for main circuit (kA)
1×250	360	9	9
2×250	360	9	9
3×250	360	9	18.5
1×315	455	11.4	11.4
2×315	455	11.4	11.4
3×315	455	11.4	22.7
1×400	578	14.4	14.4
2×400	578	14.4	14.4
3×400	578	14.4	28.8
1×500	722	18	18
2×500	722	18	18
3×500	722	18	36.1
1×630	910	22.7	22.7
2×630	910	22.7	22.7
3×630	910	22.7	44.5
1×800	1154	19.3	19.3
2×800	1154	19.3	19.3
3×800	1154	19.3	38.5
1×1000	1444	24	24
2×1000	1444	24	24
3×1000	1444	24	48.1
1×1250	1805	30	30
2×1250	1805	30	30
3×1250	1805	30	60.1
1×1600	2310	36.5	36.5
2×1600	2310	36.5	36.5
3×1600	2310	36.5	73
1×2000	2887	48.2	48.2
2×2000	2887	48.2	48.2
3×2000	2887	48.2	96.3
1×2500	3608	60	60
2×2500	3608	60	60
1×3150	4550	75.8	75.8
2×3150	4550	75.8	75.8

Type of air circuit breaker for main circuit	Number and area of the busbar for main circuit (n × W × T)	Breaking capacity of air circuit breaker for branch circuit (kA)	Air circuit breaker for branch circuit
NA1-1000-400		9	
NA1-1000-400	2 × (5 × 30)	18.5	NA1, NM8
NA1-1000-400		27.5	
NA1-1000-630		11.4	
NA1-1000-630	2 × (5 × 40)	22.7	NA1, NM8
NA1-1000-630		34.1	
NA1-1000-630		14.4	
NA1-1000-630	2 × (5 × 40)	28.8	NA1, NM8
NA1-1000-630		43.2	
NA1-1000-800		18	
NA1-1000-800	2 × (6 × 50)	36.1	NA1, NM8
NA1-1000-800		54.1	
NA1-1000-1000		22.7	
NA1-1000-1000	2 × (8 × 50)	44.5	NA1, NM8
NA1-2000-1000		67.2	
NA1-2000-1250		19.3	
NA1-2000-1250	2 × (10 × 60)	38.5	NA1, NM8
NA1-2000-1250		57.8	
NA1-2000-1600		24	
NA1-2000-1600	2 × (12 × 60)	48.1	NA1, NM8
NA1-2000-1600		72.1	
NA1-2000-2000		30	
NA1-2000-2000	3 × (10 × 60)	60.1	NA1, NM8
NA1-2000-2000		90.1	
NA1-3200-2500		36.5	
NA1-3200-2500	2 × (10 × 100)	73	NA1, NM8
NA1-3200-2500		109.5	
NA1-3200-3200		48.2	
NA1-3200-3200	4 × (10 × 100)	96.3	NA1, NM8
NA1-3200-3200		144.5	
NA1-6300-4000		60	
NA1-6300-4000	4 × (10 × 120)	120	NA1, NM8
NA1-6300-5000		75.8	
NA1-6300-5000	7 × (10 × 100)	151.6	NA1, NM8

13. Selectivity protection

13.1 Selective protection between NM8 and NA1

			Circuit breaker	NA1-2000			
Downstream	Upstream	Rated current (A)	630	800	1000	1250	
		Default setting ratings of short time-delay 8In (kA)	5.04	6.4	8	10	
		Setting range (kA)	0.63~9.45	0.8~12	1~15	1.25~18.75	
		Delayed tripping time (s)	0.1, 0.2, 0.3, 0.4				
		Returnable time	0.06, 0.14, 0.19, 0.25				
Frame size rated current	Rated current (A)	Instantaneous setting ratings (kA)					
NM8-125 NM8S-125	16	0.16 0.19(motor)	0.63~9.45 0.63~9.45	0.8~12 0.8~12	1~15 1~15	1.25~18.75 1.25~18.75	
	20	0.2 0.24(motor)	0.63~9.45 0.63~9.45	0.8~12 0.8~12	1~15 1~15	1.25~18.75 1.25~18.75	
	25	0.25 0.30(motor)	0.63~9.45 0.63~9.45	0.8~12 0.8~12	1~15 1~15	1.25~18.75 1.25~18.75	
	32	0.32 0.38(motor)	0.63~9.45 0.63~9.45	0.8~12 0.8~12	1~15 1~15	1.25~18.75 1.25~18.75	
	40	0.40 0.48(motor)	0.63~9.45 0.6624~9.45	0.8~12 0.8~12	1~15 1~15	1.25~18.75 1.25~18.75	
	50	0.50 0.60(motor)	0.69~9.45 0.828~9.45	0.8~12 0.828~12	1~15 1~15	1.25~18.75 1.25~18.75	
	63	0.63 0.75(motor)	0.8694~9.45 1.035~9.45	0.8694~12 1.035~12	1~15 1.035~15	1.25~18.75 1.25~18.75	
	80	0.80 0.96(motor)	1.104~9.45 1.325~9.45	1.104~12 1.325~12	1.104~15 1.325~15	1.25~18.75 1.325~18.75	
	100	1.0 1.20(motor)	1.38~9.45 1.656~9.45	1.38~12 1.656~12	1.38~15 1.656~15	1.38~18.75 1.656~18.75	
	125	1.25 1.5(motor)	1.725~9.45 2.07~9.45	1.725~12 2.07~12	1.725~15 2.07~15	1.725~18.75 2.07~18.75	
NM8-250 NM8S-250	100	1.0 1.2(motor)	1.38~9.45 1.656~9.45	1.38~12 1.656~12	1.38~15 1.656~15	1.38~18.75 1.656~18.75	
	160	1.6 1.92(motor)	2.208~9.45 2.65~9.45	2.208~12 2.65~12	2.208~15 2.65~15	2.208~18.75 2.65~18.75	
	200	2.0 2.4(motor)	2.76~9.45 3.312~9.45	2.76~12 3.312~12	2.76~15 3.312~15	2.76~18.75 3.312~18.75	
	250	2.5 3.0(motor)	3.45~9.45 4.14~9.45	3.45~12 4.14~12	3.45~15 4.14~15	3.45~18.75 4.14~18.75	

		NA1-3200				NA1-4000	NA1-6300		
	1600	2000	2000	2500	3200	4000	4000	5000	6300
	12.8	16	16	20	25.6	32	32	40	50.4
	1.6~24	2~30	2~30	2.5~37.5	3.2~48	4~60	4~60	5~75	6.3~94.5
0.1, 0.2, 0.3, 0.4									
0.06, 0.14, 0.19, 0.25									
	1.6~24	2~30	2~30	2.5~37.5	3.2~48	4~60	4~60	5~75	6.3~94.5
	1.6~24	2~30	2~30	2.5~37.5	3.2~48	4~60	4~60	5~75	6.3~94.5
	1.6~24	2~30	2~30	2.5~37.5	3.2~48	4~60	4~60	5~75	6.3~94.5
	1.6~24	2~30	2~30	2.5~37.5	3.2~48	4~60	4~60	5~75	6.3~94.5
	1.6~24	2~30	2~30	2.5~37.5	3.2~48	4~60	4~60	5~75	6.3~94.5
	1.6~24	2~30	2~30	2.5~37.5	3.2~48	4~60	4~60	5~75	6.3~94.5
	1.6~24	2~30	2~30	2.5~37.5	3.2~48	4~60	4~60	5~75	6.3~94.5
	1.6~24	2~30	2~30	2.5~37.5	3.2~48	4~60	4~60	5~75	6.3~94.5
	1.6~24	2~30	2~30	2.5~37.5	3.2~48	4~60	4~60	5~75	6.3~94.5
	1.6~24	2~30	2~30	2.5~37.5	3.2~48	4~60	4~60	5~75	6.3~94.5
	1.6~24	2~30	2~30	2.5~37.5	3.2~48	4~60	4~60	5~75	6.3~94.5
	1.6~24	2~30	2~30	2.5~37.5	3.2~48	4~60	4~60	5~75	6.3~94.5
	1.6~24	2~30	2~30	2.5~37.5	3.2~48	4~60	4~60	5~75	6.3~94.5
	1.6~24	2~30	2~30	2.5~37.5	3.2~48	4~60	4~60	5~75	6.3~94.5
	1.656~24	2~30	2~30	2.5~37.5	3.2~48	4~60	4~60	5~75	6.3~94.5
	1.725~24	1.725~30	1.725~30	1.725~37.5	1.725~48	1.725~60	1.725~60	1.725~75	1.725~94.5
	2.07~24	2.07~30	2.07~30	2.07~37.5	2.07~48	2.07~60	2.07~60	2.07~75	2.07~94.5
	1.6~24	2~30	2~30	2.5~37.5	3.2~48	4~60	4~60	5~75	6.3~94.5
	1.656~24	2~30	2~30	2.5~37.5	3.2~48	4~60	4~60	5~75	6.3~94.5
	2.208~24	2.208~30	2.208~30	2.5~37.5	3.2~48	4~60	4~60	5~75	6.3~94.5
	2.65~24	2.65~30	2.65~30	2.65~37.5	3.2~48	4~60	4~60	5~75	6.3~94.5
	2.76~24	2.76~30	2.76~30	2.76~37.5	3.2~48	4~60	4~60	5~75	6.3~94.5
	3.312~24	3.312~30	3.312~30	3.312~37.5	3.312~48	4~60	4~60	5~75	6.3~94.5
	3.45~24	3.45~30	3.45~30	3.45~37.5	3.45~48	4~60	4~60	5~75	6.3~94.5
	4.14~24	4.14~30	4.14~30	4.14~37.5	4.14~48	4.14~60	4.14~60	5~75	6.3~94.5

			Circuit breaker	NA1-2000				
Downstream			Upstream	Rated current (A)	630	800	1000	1250
				Default setting ratings of short time-delay 8In (kA)	5.04	6.4	8	10
				Setting range (kA)	0.63~9.45	0.8~12	1~15	1.25~18.75
				Delayed tripping time (s)	0.1, 0.2, 0.3, 0.4			
				Returnable time	0.06, 0.14, 0.19, 0.25			
Frame size rated current	Rated current (A)	Instantaneous setting ratings (kA)						
NM8-630 NM8S-630	250	2.5		3.45~9.45	3.45~12	3.45~15	3.45~18.75	
		3.0(motor)		4.14~9.45	4.14~12	4.14~15	4.14~18.75	
	315	3.15		4.347~9.45	4.347~12	4.347~15	4.347~18.75	
		3.78(motor)		5.216~9.45	5.216~12	5.216~15	5.216~18.75	
350	3.5		4.83~9.45	4.83~12	4.83~15	4.83~18.75		
	4.2(motor)		5.796~9.45	5.796~12	5.796~15	5.796~18.75		
400	4.0		5.52~9.45	5.52~12	5.52~15	5.52~18.75		
	4.8(motor)		6.624~9.45	6.624~12	6.624~15	6.624~18.75		
NM8S-630	500	5.0		6.9~9.45	6.9~12	6.9~15	6.9~18.75	
		6.0(motor)		8.28~9.45	8.28~12	8.28~15	8.28~18.75	
	630	6.3		8.694~9.45	8.694~12	8.694~15	8.694~18.75	
		7.56(motor)			10.44~12	10.44~15	10.44~18.75	
NM8-1250 NM8S-1250	630	6.3		8.694~9.45	8.694~12	8.694~15	8.694~18.75	
		7.56(motor)			10.44~12	10.44~15	10.44~18.75	
	700	7.0			9.66~12	9.66~15	9.66~18.75	
		8.4(motor)			11.59~12	11.59~15	11.59~18.75	
800	8.0			11.04~12	11.04~15	11.04~18.75		
	9.6(motor)				13.25~15	13.25~18.75		
1000	10				13.8~15	13.8~18.75		
	12(motor)					16.56~18.75		
1250	12.5					17.25~18.75		
	15.0(motor)							

			NA1-3200			NA1-4000	NA1-6300		
	1600	2000	2000	2500	3200	4000	4000	5000	6300
	12.8	16	16	20	25.6	32	32	40	50.4
	1.6~24	2~30	2~30	2.5~37.5	3.2~48	4~60	4~60	5~75	6.3~94.5
0.1, 0.2, 0.3, 0.4									
0.06, 0.14, 0.19, 0.25									
	3.45~24	3.45~30	3.45~30	3.45~37.5	3.45~48	4~60	4~60	5~75	6.3~94.5
	4.14~24	4.14~30	4.14~30	4.14~37.5	4.14~48	4.14~60	4.14~60	5~75	6.3~94.5
	4.347~24	4.347~30	4.347~30	4.347~37.5	4.347~48	4.347~60	4.347~60	5~75	6.3~94.5
	5.216~24	5.216~30	5.216~30	5.216~37.5	5.216~48	5.216~60	5.216~60	5.216~75	6.3~94.5
	4.83~24	4.83~30	4.83~30	4.83~37.5	4.83~48	4.83~60	4.83~60	5~75	6.3~94.5
	5.796~24	5.796~30	5.796~30	5.796~37.5	5.796~48	5.796~60	5.796~60	5.796~75	6.3~94.5
	5.52~24	5.52~30	5.52~30	5.52~37.5	5.52~48	5.52~60	5.52~60	5.52~75	6.3~94.5
	6.624~24	6.624~30	6.624~30	6.624~37.5	6.624~48	6.624~60	6.624~60	6.624~75	6.624~94.5
	6.9~24	6.9~30	6.9~30	6.9~37.5	6.9~48	6.9~60	6.9~60	6.9~75	6.9~94.5
	8.28~24	8.28~30	8.28~30	8.28~37.5	8.28~48	8.28~60	8.28~60	8.28~75	8.28~94.5
	8.694~24	8.694~30	8.694~30	8.694~37.5	8.694~48	8.694~60	8.694~60	8.694~75	8.694~94.5
	10.44~24	10.44~30	10.44~30	10.44~37.5	10.44~48	10.44~60	10.44~60	10.44~75	10.44~94.5
	8.694~24	8.694~30	8.694~30	8.694~37.5	8.694~48	8.694~60	8.694~60	8.694~75	8.694~94.5
	10.44~24	10.44~30	10.44~30	10.44~37.5	10.44~48	10.44~60	10.44~60	10.44~75	10.44~94.5
	9.66~24	9.66~30	9.66~30	9.66~37.5	9.66~48	9.66~60	9.66~60	9.66~75	9.66~94.5
	11.59~24	11.59~30	11.59~30	11.59~37.5	11.59~48	11.59~60	11.59~60	11.59~75	11.59~94.5
	11.04~24	11.04~30	11.04~30	11.04~37.5	11.04~48	11.04~60	11.04~60	11.04~75	11.04~94.5
	13.25~24	13.25~30	13.25~30	13.25~37.5	13.25~48	13.25~60	13.25~60	13.25~75	13.25~94.5
	13.8~24	13.8~30	13.8~30	13.8~37.5	13.8~48	13.8~60	13.8~60	13.8~75	13.8~94.5
	16.56~24	16.56~30	16.56~30	16.56~37.5	16.56~48	16.56~60	16.56~60	16.56~75	16.56~94.5
	17.25~24	17.25~30	17.25~30	17.25~37.5	17.25~48	17.25~60	17.25~60	17.25~75	17.25~94.5
	20.7~24	20.7~30	20.7~30	20.7~37.5	20.7~48	20.7~60	20.7~60	20.7~75	20.7~94.5

13.2 Selective protection in NA1

			Circuit breaker	NA1-2000				
Downstream			Upstream	Rated current (A)	630	800	1000	1250
				Default setting ratings of short time-delay 8In (kA)	5.04	6.4	8	10
				Setting range (kA)	0.63~9.45	0.8~12	1~15	1.25~18.75
				Delayed tripping time (s)	0.1, 0.2, 0.3, 0.4			
				Returnable time	0.06, 0.14, 0.19, 0.25			
Frame size rated current	Rated current (A)	Default instantaneous setting ratings 12In (kA)						
NA1-2000	400	4.8		6.348~9.45	6.348~12	6.348~15	6.348~18.75	
	630	7.56			9.998~12	9.998~15	9.998~18.75	
	800	9.6				12.696~15	12.696~18.75	
	1000	12					15.87~18.75	
	1250	15						
	1600	19.2						
	2000	24						
NA1-3200	2500	30						
	3200	38.4						
NA1-4000	4000	48						
NA1-6300	4000	48						
	5000	60						
	6300	75						

Note: It can satisfy the selective protection if only the short time-delay setting value of the superior breaker 1.32 times more than the subordinate breaker, when the instantaneous setting value is adjustable.

			NA1-3200			NA1-4000	NA1-6300		
	1600	2000	2000	2500	3200	4000	4000	5000	6300
	12.8	16	16	20	25.6	32	32	40	50.4
	1.6~24	2~30	2~30	2.5~37.5	3.2~48	4~60	4~60	5~75	6.3~94.5

0.1, 0.2, 0.3, 0.4

0.06, 0.14, 0.19, 0.25

	6.348~24	6.348~30	6.348~30	6.348~37.5	6.348~48	6.348~60	6.348~60	6.348~75	6.348~94.5
	9.998~24	9.998~30	9.998~30	9.998~37.5	9.998~48	9.998~60	9.998~60	9.998~75	9.998~94.5
	12.696~24	12.696~30	12.696~30	12.696~37.5	12.696~48	12.696~60	12.696~60	12.696~75	12.696~94.5
	15.87~24	15.87~30	15.87~30	15.87~37.5	15.87~48	15.87~60	15.87~60	15.87~75	15.87~94.5
	19.837~24	19.837~30	19.837~30	19.837~37.5	19.837~48	19.837~60	19.837~60	19.837~75	19.837~94.5
		25.392~30	25.392~30	25.392~37.5	25.392~48	25.392~60	25.392~60	25.392~75	25.392~94.5
				31.74~37.5	31.74~48	31.74~60	31.74~60	31.74~75	31.74~94.5
				31.74~37.5	31.74~48	31.74~60	31.74~60	31.74~75	31.74~94.5
					39.675~48	39.675~60	39.675~60	39.675~75	39.675~94.5
						50.784~60	50.784~60	50.784~75	50.784~94.5
								63.48~75	63.48~94.5
								63.48~75	63.48~94.5
									79.35~94.5

14. Intelligent controller

14.1 The intelligent controller of NA1-1000

a. The standard M type intelligent controller (NA1-1000)

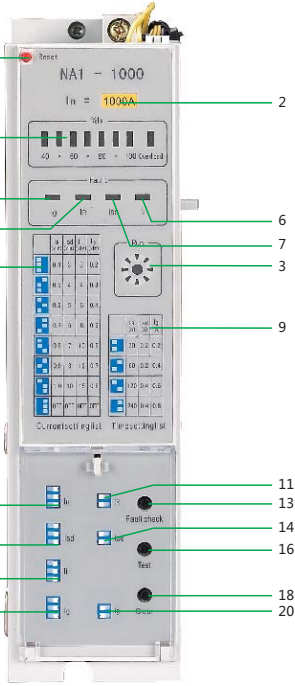

1: Reset key
 2: Rated current
 3: MCU indicator(normal operation indicator)
 4: Current indicator
 5: Earthing fault indicator
 6: Short circuit instantaneous fault indicator
 7: Short circuit short time-delay fault indicator
 8: Overload fault indicator
 9: Time setting table
 10: Current setting table
 11: Overload long time-delay time setting key
 12: Overload long time-delay current setting key
 13: Fault cheking key
 14: Short circuit short time-delay time setting key
 15: Short circuit short time-delay current setting key
 16: Test key
 17: Short circuit instantaneous current setting key
 18: Clear LED key
 19: Earthing current setting key
 20: Earthing time setting key

The function of keys show as followed:
 "Fault checking" key: After the breaker tripping, press this key to indicate the kind of fault.
 "Test key" key: used for checking the controller and the action of the breaker.
 "Clear LED" key: After the setting,testing and fault checking of the controller, make the circuit breaker at normal operation.

b. The communication H type intelligent controller(NA1-1000)

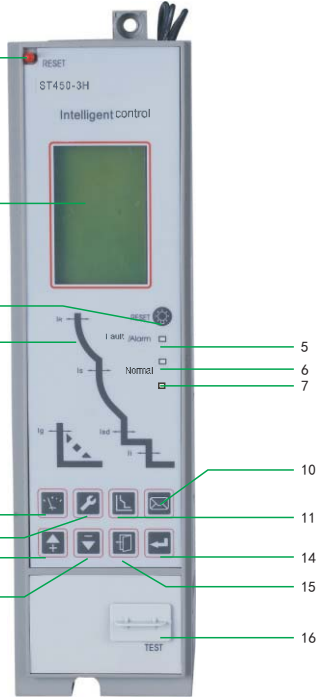

1: Reset key
 2: LCD display window
 3: Fault and alarm reset key
 4: Curve LED indication
 5: "Fault/alarm" LED
 6: "Normal" LED
 7: "Communication" indicator
 8: Test key
 9: Setting key
 10: Message key
 11: Protection key
 12: Increasing key
 13: Decreasing key
 14: Choosing key
 15: Exit key
 16: Testing port

c. Basic functions

● stands for definite setting

■ stands for optional setting

— stands for no function

Controller type		Standard (M type)		Communication (H type)	
		Three cascades protection	Four cascades protection	Three cascades protection	Four cascades protection
Basic function	Long time-delay protection	●	●	●	●
	Short time-delay protection	●	●	●	●
	Instantaneous protection	●	●	●	●
	Earthing fault protection	—	●	●	●
	Load current display	●	●	●	●
	Load current digital display (Ampere Meter)	—	—	●	●
	Test function	●	●	●	●
	Fault recall	●	●	●	●
	Self-diagnose function	—	—	●	●
	MCR making and breaking function	●	●	●	●
	Fault alarm	●	●	●	●
	Fault breaking indication	●	●	●	●
	Customer setting, testing	●	●	●	●
	Load monitor	—	—	■	■
Optional auxiliary function	RS485 port MODBUS protocol	—	—	●	●
	Voltage measuring	—	—	■	■
	Frequency display	—	—	■	■
	Active power measuring	—	—	■	■
	Power factor measuring	—	—	■	■
	Electric energy measuring	—	—	■	■
	Over voltage protection	—	—	■	■
	Under voltage protection	—	—	■	■
	Phase protection	—	—	■	■
	Current transformer earthing protection	■ (3P+N model)	■ (3P+N model)	■	■
	Exceed breaking function	—	—	■	■
Thermal recall function	—	—	■	■	
Four output contacts	—	—	●	●	
Man-machine interface instruction		LED display, code switch and toggle switch setting		LCD display, LED indication, keyboard operation	

d. Operation instructions

Standard intelligent controller setting

According to the panel number 9 showed, dial the switch 11,14,20 to set the time you need.

According to the panel number 10 showed, dial the switch 12,15,17,19 to set the current you need.

Example 1: means that overload long time-delay current is $0.8I_n$, overload long time-delay time is 60s.

Example 2: means that short circuit short time-delay current is $8I_n$, short circuit short time-delay time is 0.4s.

Example 1

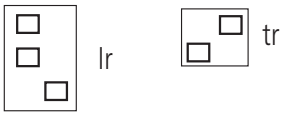

Example 2

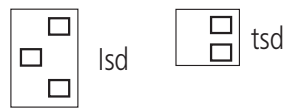

Communication intelligent controller setting and operation.
It provides 4 main menu and 1 default interface.
Default interface
Without other function action, it displays phases current column chart.

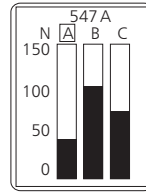

1. "Testing" menu

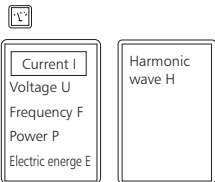

Press or key to return default interface.
On other non-fault interface, press to skip to testing menu.
Without action for several minutes, it returns to the default interface.

2. "System data setting" menu

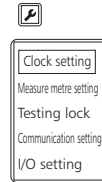

Press or key to return default interface.
On other non-fault interface, press to skip to system data setting menu.
Without action for several minutes, it returns to the default interface.

3. "Protection data setting" menu

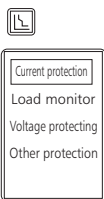

Press or key to return default interface.
On other non-fault interface, press to skip to protection data setting menu.
Without action for several minutes, it returns to the default interface.

4. "Historical record and maintain" menu

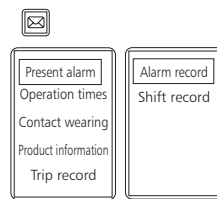

Press or key to return default interface..
On other non-fault interface, press to skip to testing menu.
Without action for several minutes, it returns to the default interface.

5. Submenu operation show:
overload longtime-delay protection setting

Long time-delay

Ir=400A

(40.0%In)

Curve type

= SI

Long time-delay

Ir=1000A

(100%In)

Curve type

= SI

Long time-delay

Ir=1000A

(100%In)

Curve type

= SI

⬆️⬆️ then ⬆️
⬆️⬆️ Setting definite value
⬆️ Save definite value

Note: communication controller actual menu will change as customers' choice.

e. Over current protection characteristic
The characteristic of intelligent controller

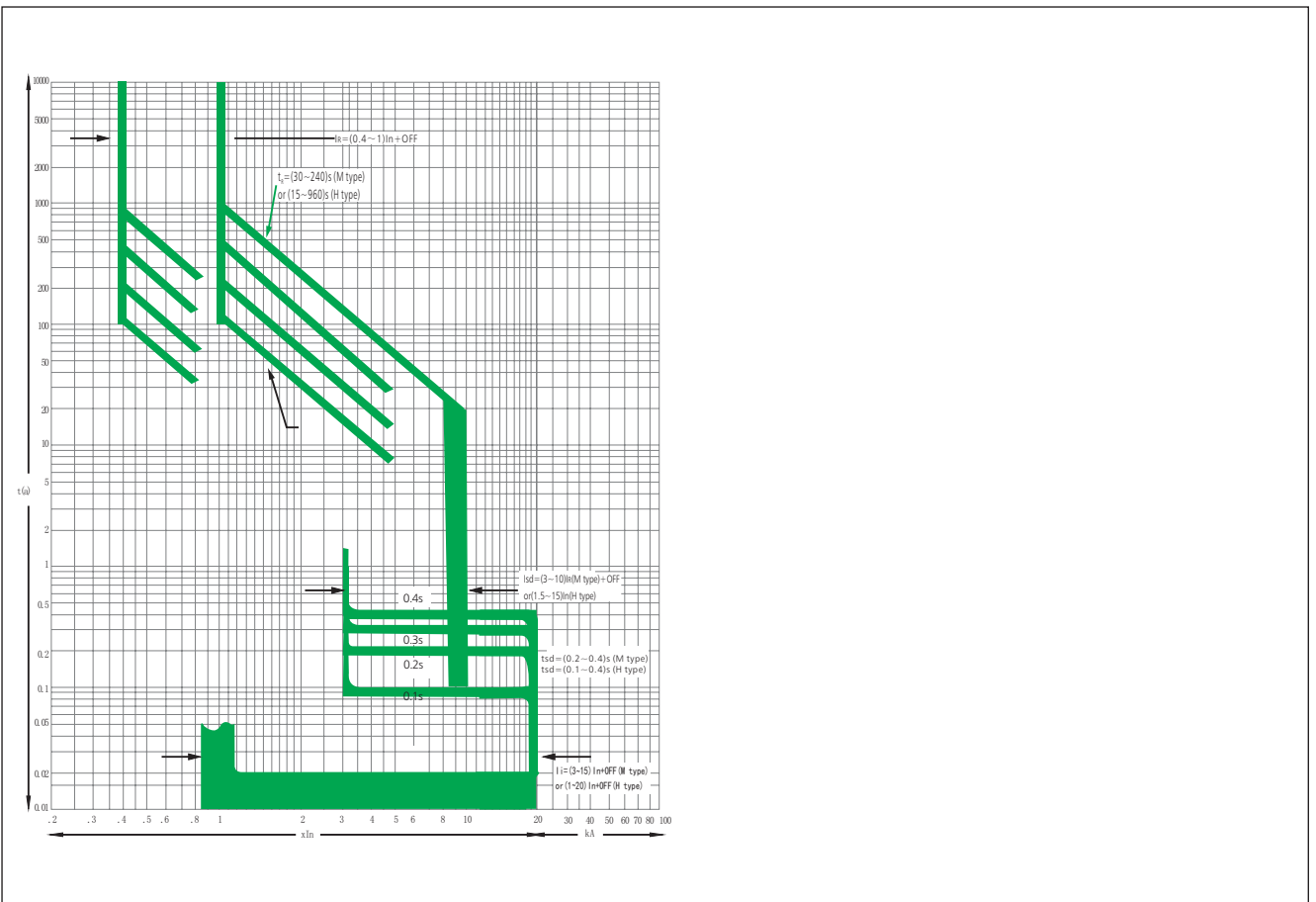

Long time-delay overcurrent protection, inverse time characteristic.

Setting current (IR)	tolerance	Current	Tripping time (s)				Time tolerance
(0.4~1)In+OFF	±10%	1.05IR	≤2h Non-trip				
		1.3IR	<1h trip				
		1.5IR(M)	30	60	120	240	±10%
		2.0IR(M)	16.9	33.8	67.5	135	±10%
		1.5IR(H)	15~960				±10%
		6.0IR(H)	0.938~60				±10%

Short time-delay overcurrent protection characteristic.

Setting current (IR)		tolerance	Setting delay time (s)				Time tolerance
	Isd		ts(s)				
M	(3~10)IR+OFF	±10%		0.2		0.4	±15%
H	OFF+(1.5~15)IR	±10%	0.1	0.2	0.3	0.4	±15%

Instantaneous characteristic.

Type	Setting current (Ii)	Tripping	tolerance
M	(3~15)In+OFF	≤0.85Ii In the 0.2s Non-trip; > 1.15Ii in the 0.2s trip	±15%
H	(1~20)In+OFF	≤0.85Ii In the 0.2s Non-trip; > 1.15Ii in the 0.2s trip	±15%

Earthing fault protection characteristic

Type	Rated current (Ig)	tolerance	Rated delay time (tg)	Time tolerance
M	(0.2~0.8)In+OFF, min 100A	±10%	0.2, 0.4, 0.6, 0.8	±15%
H	(0.2~1.0)In+OFF, min 100A	±10%	(0.1~1.0)s	±15%

Single phase earthing protection curre (M type)

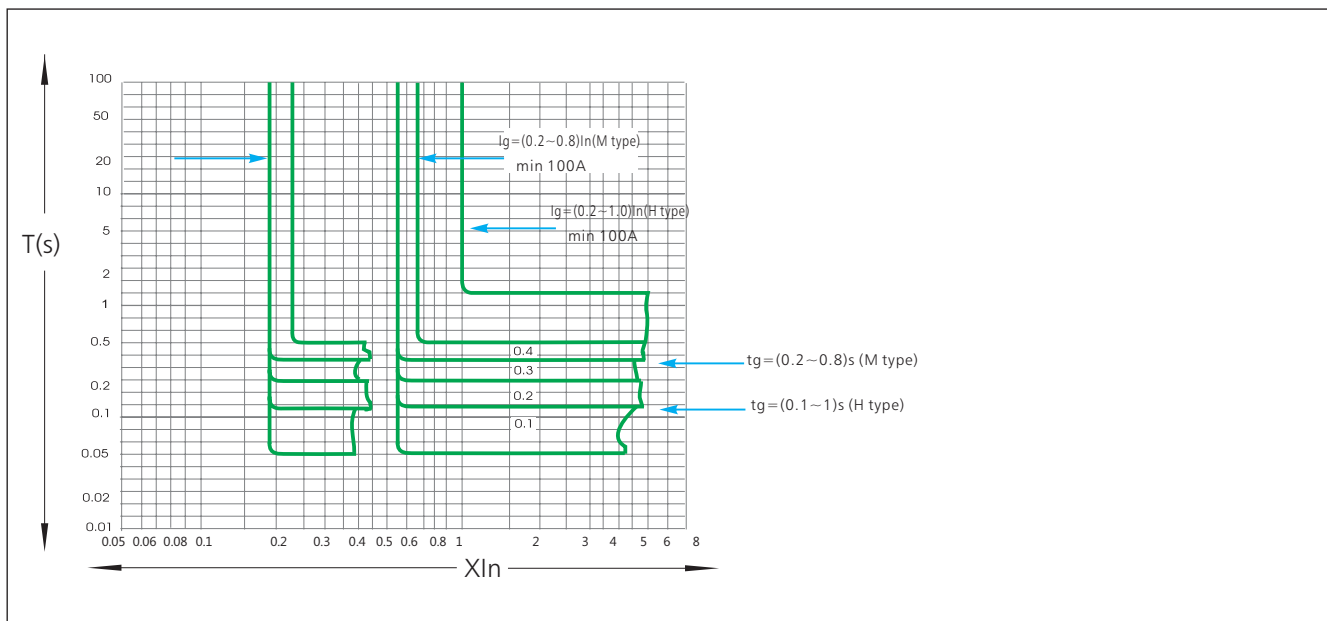

Wiring diagram of the earthing fault protection.

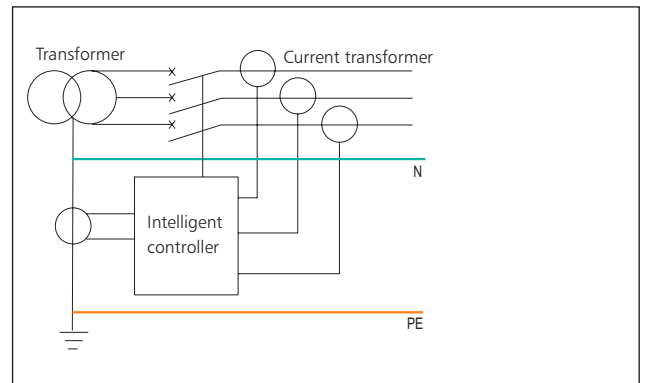
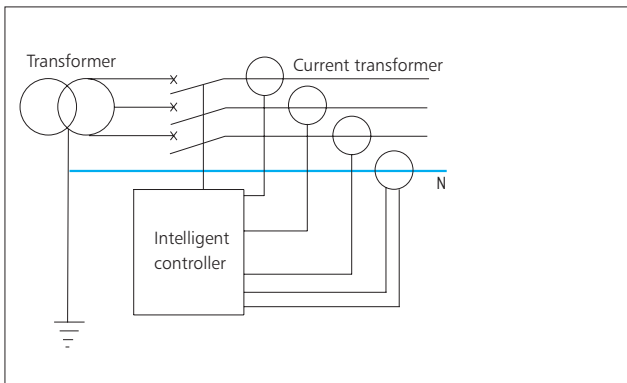
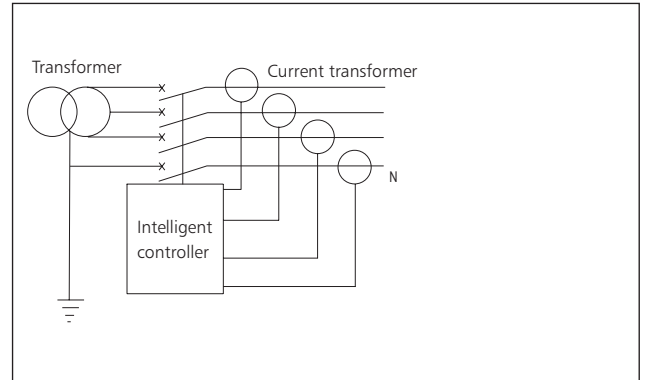
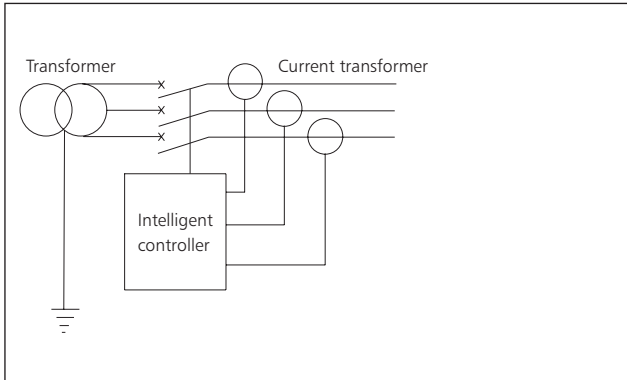

Load monitor characteristic.

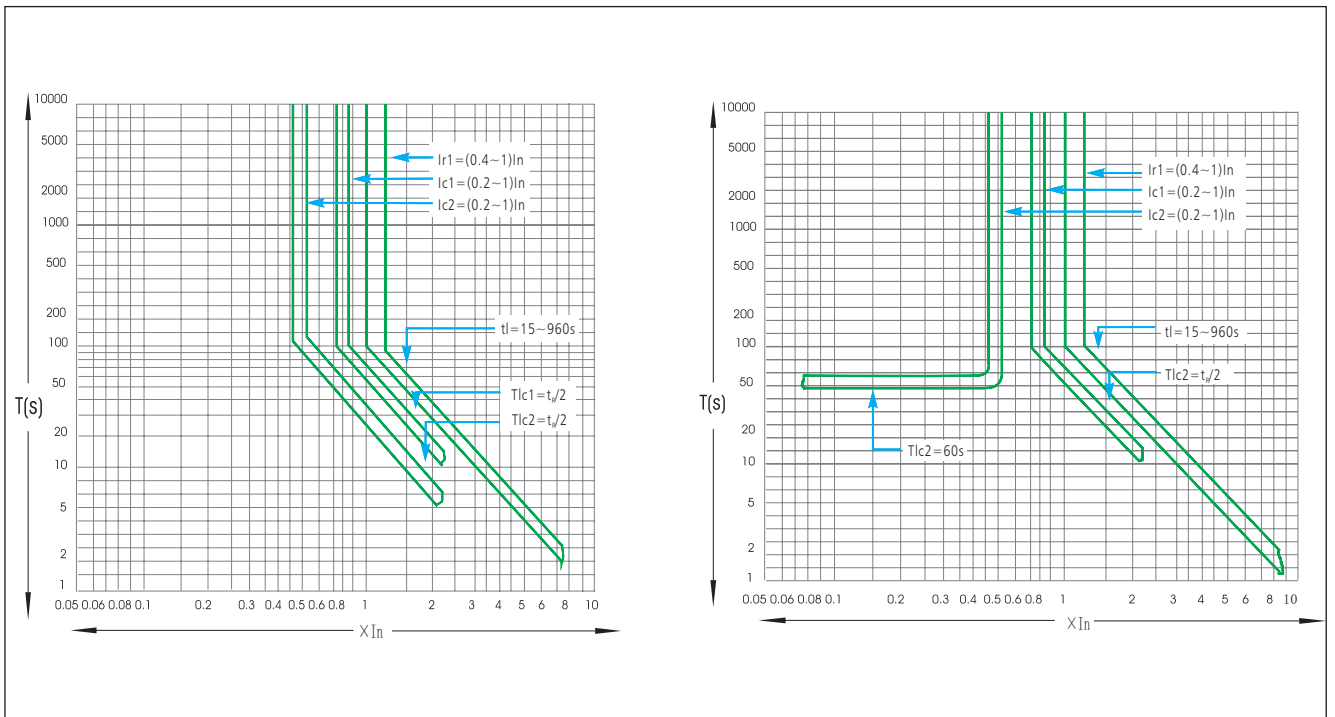

14.2 The intelligent controller of NA1-2000, 3200, 4000, 6300

14.2.1 The standard M type intelligent controller (NA1-2000 3P 4P; NA1-3200 3P 4P; NA1-4000 3P)

The M type intelligent controller is the core part of the NA1 Air Circuit Breaker to protect the electric circuit and the power supply against the dangers such as overload, short circuit and single-phase earthing fault. The controller adopts highly-integrated and high-performance digital signal processor that featuring power functions and reliable performance to perform real-time processing to the signal so as to achieve various protection function and numerous auxiliary functions.

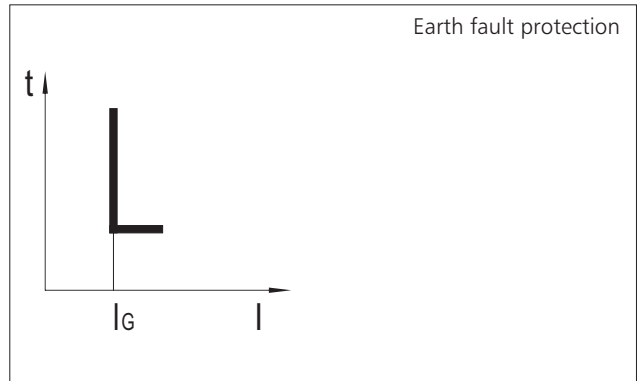
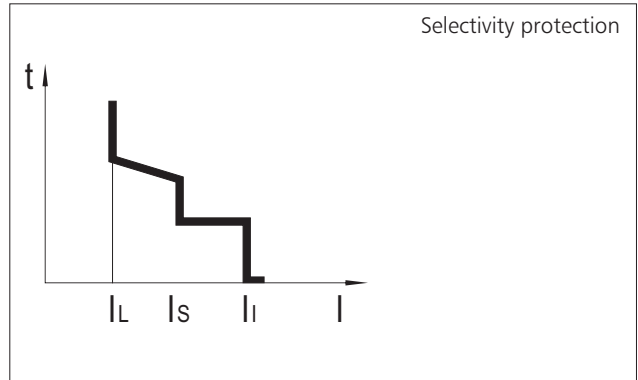
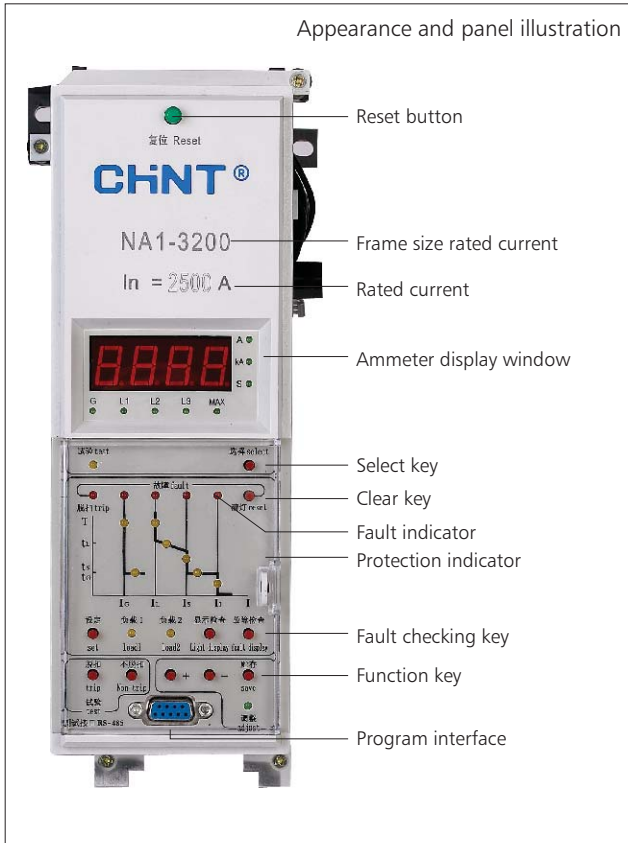

a. Symbol designation table

Number	Symbol	Designation
1	I_{nm}	Frame size rated current of breaker
2	I_n	Rated current
3	$I_L(Ir1), I_S(Ir2), I_I(Ir3)$	Action current of long time-delay, short time-delay and instantaneous
4	$I_G(Ir4)$	Action current of earth fault or phase N
5	t_L, t_S, t_G	Action time of long time-delay, short time-delay and grounding
6	L1, L2, L3, G	Phase A, B, C and N (or earth)
7	I_{c1}, I_{c2}	Action current of load monitor 1 and load monitor 2
8	T, I	Time, current
9	A, kA, s	Unit Indicator: Ampere, kilo-Ampere, second

b. Operating power supply

The operating power supply input to the intelligent controller:
AC 400V/380V, 230V/220V, AC 110V, 50Hz;
DC 220V, 110V, 24V.

c. Basic functions of intelligent controller

- Main protection function
- Query function
- Parameter setting function
- Test function
- Load monitor function (optional)
- Making current release (MCR) and High-Set Instantaneous
- Short Circuit (HSISC) function (optional)
- Signal alarm function (optional)

d. Operation instructions

Parameter setting operation
Step 1: Setting right confirmation. The key must be switched to "setting" position for type H. This step is no necessary for type M.
Step 2: Make sure the controller is under reset status. If the controller isn't under reset status, press "reset" key till the ammeter displays operation current.
Note: When the controller is under malfunction alarm status, then the setup function is locked and the setup operation can't be conducted.
Step 3: Press "set" key till the ammeter display window displays required action current or time setting.

Step 4: Press "+" and "-" to set the items to be changed.
 Step 5: Press "save" key. At that time, the "save" indicator will flash once to indicate that the parameters are saved. If not desiring to save, then directly press "reset" key. Then the parameters won't be changed and will remain the original values.
 Step 6: Repeat step 3 ~ step 5 in case requiring changing other parameters. If not, press "reset" key till the characteristic curve indicator is off.
 Note: In case of occurrence of malfunction under setup status, it will automatically exit the setup status and enter into malfunction status.
 During the adjustment of the parameters, the longer the time of pressing or holding the "+" or "-" key is, the faster the up or down speed is.

Failure inquiry operation
 Query operation method
 Step 1: Make sure the controller is under reset status.
 Step 2: Press "fault display" key till the ammeter display window indicates the failure action value and the action time alternately. Press "select" to inquiry relevant parameters.
 Step 3: Press "reset" key to exit the inquiry status.

Test operation method
 Step 1: Make sure the controller is under reset status.
 Step 2: Press "set" key till the indicator of the short time-delay characteristic curve current is on. Press "+" "-" to adjust the required current.
 Press "trip" key, then the breaker will trip. The ammeter display window will display the action current and action time in turn.
 Step 3: Press "reset" key to exit the test status.

e. Characteristic

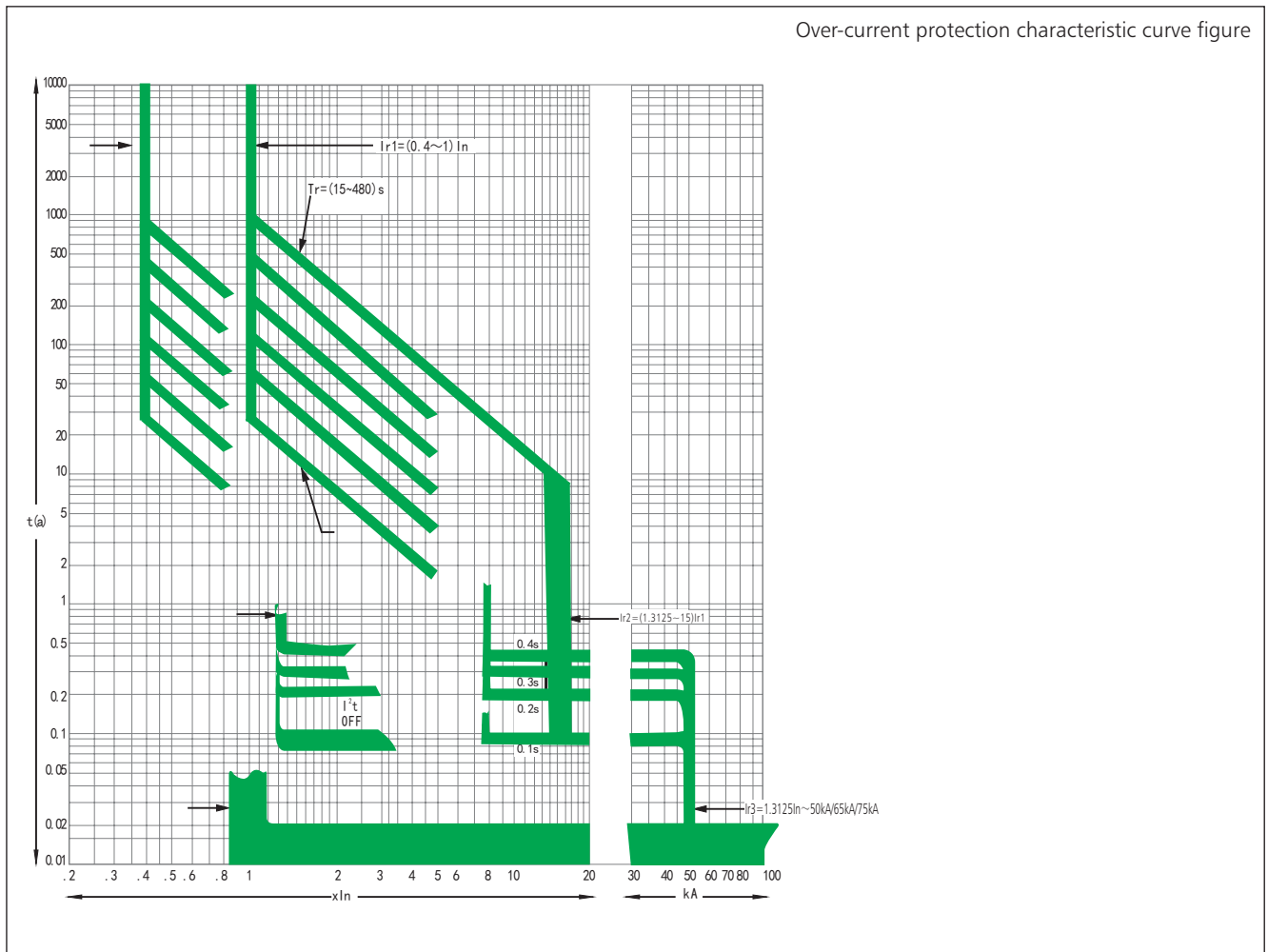

Overload long time-delay protection

Current Ratings Range(Ir1)	tolerance	Current	Action Time						Time tolerance
(0.4~1) In + OFF	± 10%	≤ 1.05Ir1	< 2h Non-trip						
		> 1.30Ir1	< 1h trip						
		1.51Ir1 (setting time)	15	30	60	120	240	480	± 10%
		2.0Ir1	8.4	16.9	33.7	67.5	135	270	± 10%
Phase N Overload and Over-Current Characteristic			100% or 50% (Applicable to 3P+N or 4P)						

Short-circuit short-delay protection

Current Ratings Range(Ir2)	Tolerance	Current	Action Time				Time tolerance
NA1-2000 1.3125Ir1~15Ir1+OFF (OFF Position) NA1-3200, 4000 1.3125Ir1~15Ir1+OFF (OFF Position), Ir2≤40kA NA1-6300 1.3125Ir1~15Ir1+OFF (OFF Position), Ir2≤50kA	±10%	≤0.9Ir2	In the 2ts Non-trip				
		>1.10Ir2	In the 2ts Delayed-trip				
		Time setting (ts)	0.1	0.2	0.3	0.4	±25%
		Returnable Time	0.06	0.14	0.19	0.25	±25%

Short circuit instantaneous protection

Current Ratings Range(Ir3)	Tolerance	Current	Action Characteristic
NA1-2000 1.3125In~50kA NA1-3200, 4000 1.3125In~65kA NA1-6300 1.3125In~75kA	±15%	≤0.85Ir3	In the 0.2s Non-trip
>1.15Ir3		In the 0.2s trip	

f. Earth fault protection

The earth fault protection has definite time-delay characteristic with the failure delayed time no less than the definite time-delay time setting.

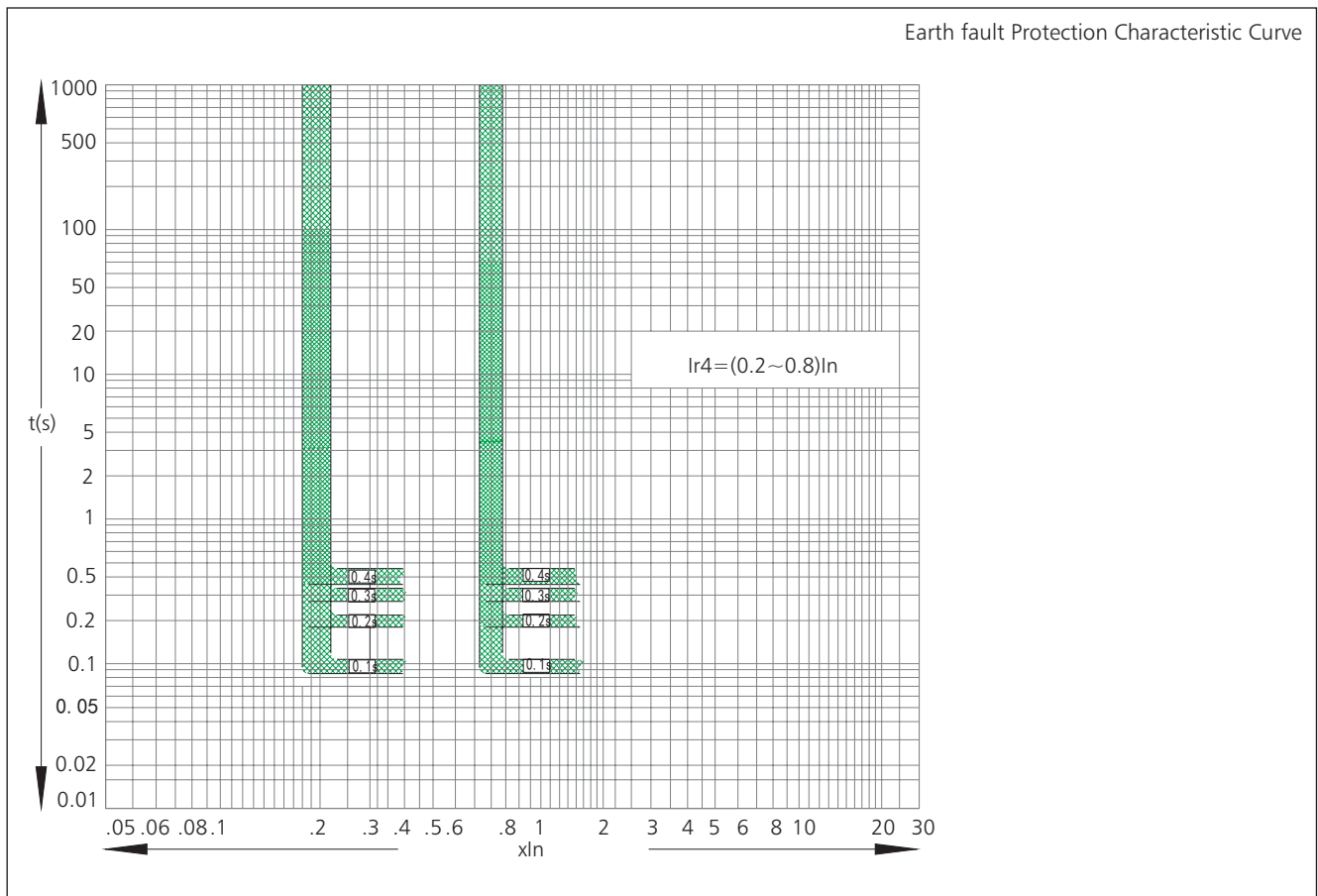

Single phase earth fault protection technical data:

Current Ratings Range(Ir4)	Tolerance	Current	Action Time				Time tolerance
In=630A, Ir4 =160A~0.8In+OFF In>630A, Ir4 =(0.2~0.8)In+OFF	±10%	≤0.9 Ir4	In the 2tg Non-tripping				
		>1.1 Ir4	In the tg±0.032s or tg(1±25%) Tripping				
		Setting time (Tg)	0.1	0.2	0.3	0.4	±25%
		Returnable time	0.06	0.14	0.19	0.25	±25%

14.3 NA1 Multifunctional Intelligent Controller

a. Menu Operation Explanation

Display operation kneading board

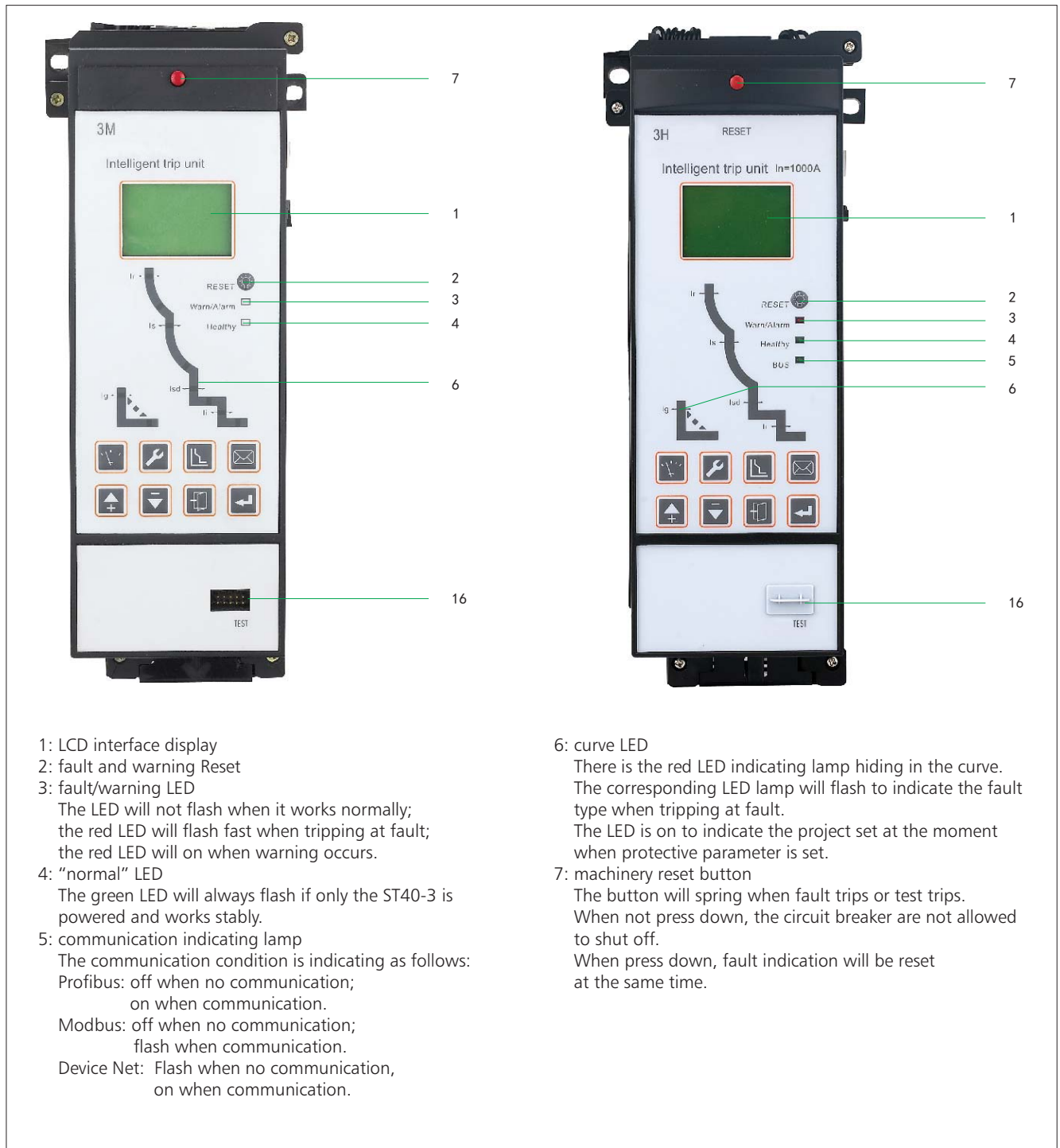

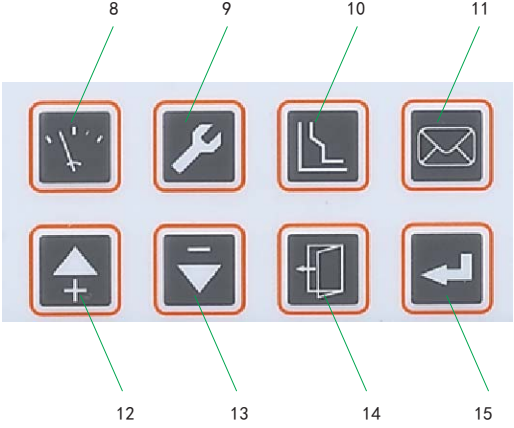

8: Measure— function key 1, switch to measure default theme menu (the key in the password input interface is “left”)
 9: Set— function key 2, switch to parameter set theme menu (the key in the password input interface is “right”)
 10: protection—function key 3, switch to protection parameter set theme menu.
 11: Information—function key 4, switch to history and maintenance theme menu.
 12: Up—up to move the menu content under the current used grade, or up to change the chose parameter.
 13: Down—down to move the menu content under the current used grade, or down to change the chose parameter.
 14: Escape—to escape from this grade and return to upper menu; or cancel the current parameter selected.
 15: Select—enter into the next menu directed by the current item, or for the current parameter selected and store modifications.

16: Test port—The bottom of the front board has a 16 pin test port, which can insert a inserted portable power supply or inspection unit.

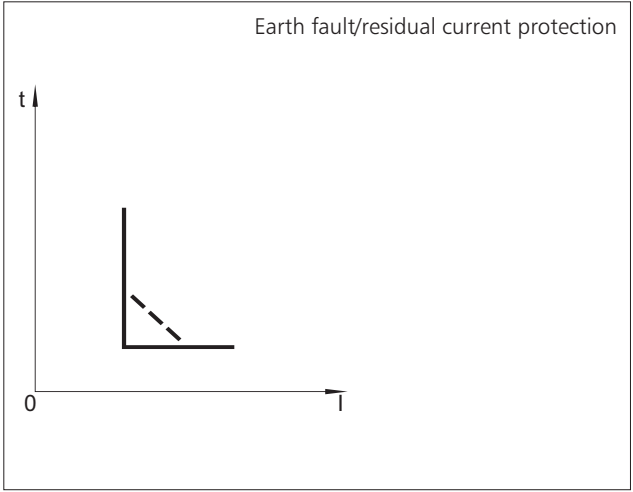
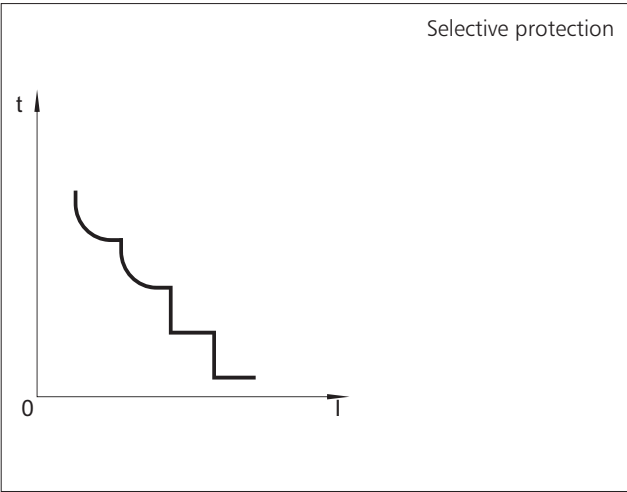

b. Panorama of intelligent controllers for NA1 series

Type	Rated current (A)	Number of poles	M	3M	3H
NA1-2000	630 800 1000 1250 1600 2000	3P, 4P	Yes	Yes	Yes
NA1-3200	2000 2500 3200		Yes	Yes	Yes
NA1-4000	4000		Yes	Yes	Yes
NA1-6300	4000 5000		Yes	Yes	Yes
	6300	3P	Yes	Yes	Yes

- c. NA1 Multifunctional Intelligent Controller subject menu
NA1 Multifunctional Intelligent controller has provided
4 subject menu and 1 default interface

1. Default interface

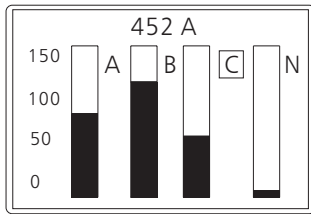

- The controller displays the default interface when on electricity.
- Under each subject menu, press or the corresponding subject key can return to default interface.
- If don't press any keys in 5 minutes and then the pane cursor will show the maximum phase automatically.
- In the non-activated fault interface, if don't press any key in 30 minutes and then will automatically return to the default interface.

2. "measure" menu

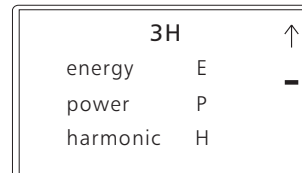
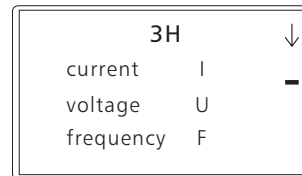

- press to enter into measure main menu
- press or to return to default interface
- In other non-fault interface, press to jump to measure menu

3. "system parameter set" menu

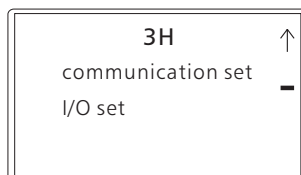
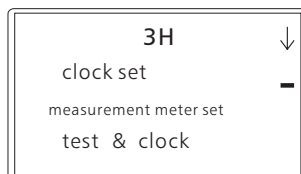

- Press or to return to default interface
- In other non-fault interface, press to jump to system parameter set menu

4. "protection parameter set" menu

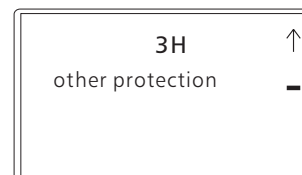
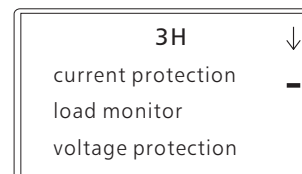

- Press or to return to default interface
- In other non-fault interface, press to jump to protection parameter set menu

5. "history and maintenance" menu



3H ↓
current warning -
operating time
contact wearout

3H ↕
production information -
release record
warning record

3H ↑
Variable-record -

- Press or to return to default interface
- In other non-fault interface, press to jump to history and maintenance menu

6. Sub-menu operation example:
overload long delay protection set

Ir ↑
= 1000 A = 40.4 %In -
curve type
= VI

Ir ↑
→ 1200 A = 48.0 %In -
curve type
= VI

Ir ↑
= 1200 A = 48.0 %In -
curve type
= VI

then adjust fixed value save fixed value

d. Instruction to technical property

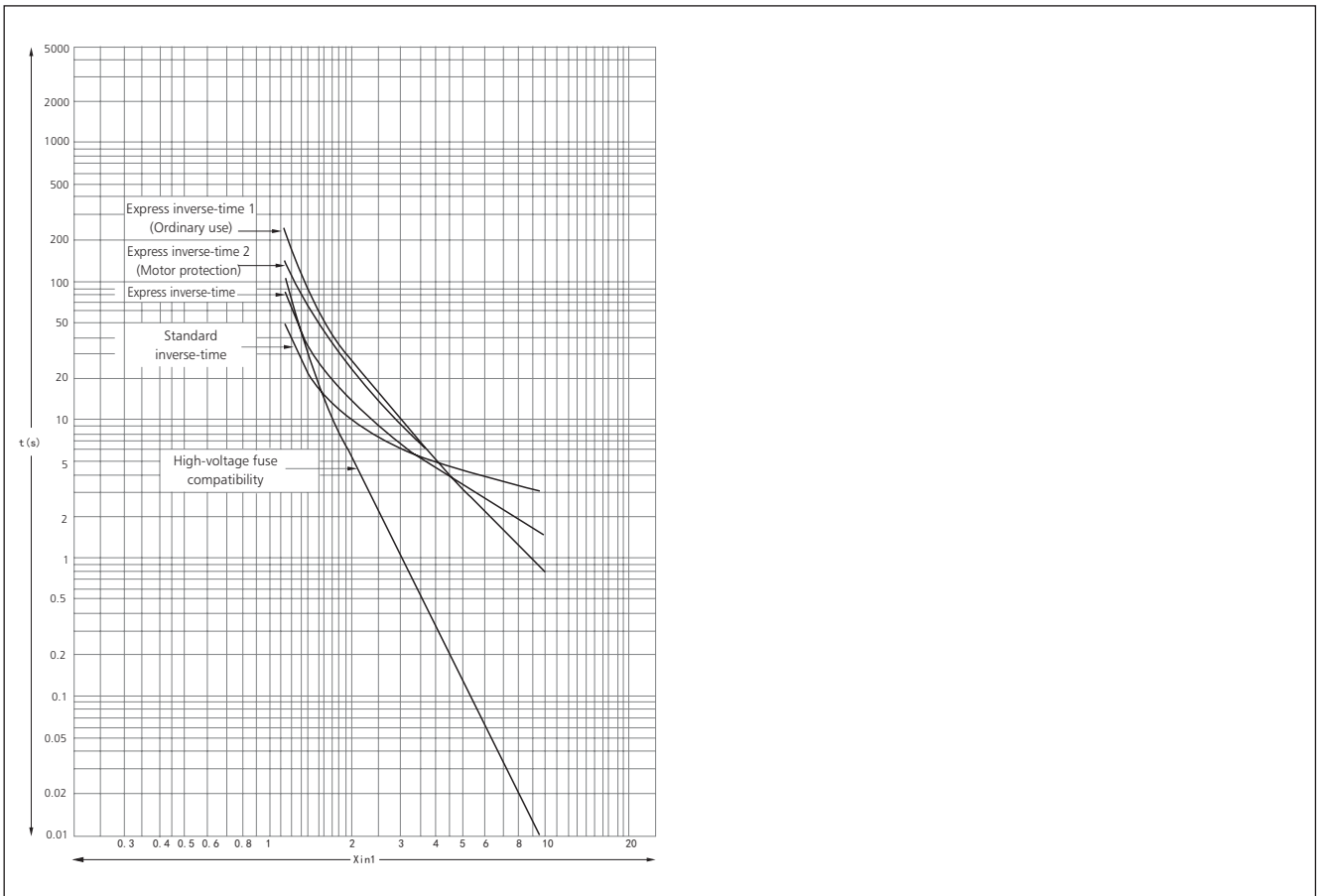

Function of intelligent controller

● stands for definite setting ■ stands for optional setting — stands for no function

Function configuration	Type		
	M	3M	3H
Current display function	●	●	●
Overload long time delay protection(inverse)	●	●	●
Short circuit short time delay protection(inverse and definite)	●	●	●
Short circuit instantaneous protection	●	●	●
Single-phase earthing fault protection	●	●	●
Current imbalance protection caused by phase failure	—	●	●
Parameter setting function	●	●	●
Test(simulate trip) function	●	●	●
Inquiry function	●	●	●
Self-diagnose function	—	●	●
Programing interface function	—	●	●
Communication function	—	—	●
Contact abrasion extent record	—	●	●
Operating times record	—	●	●
Clock function	—	●	●
Alarm record	—	●	●
Position (making, energy storage or breaking) change record	—	●	●
The history current peak value record	—	●	●
MCR(Making current release) and HSISC(High-setting instantaneous short circuit)	●	●	●
Current leakage protection(inverse and definite)	—	■	■
Neutral (N phase) protection	—	●	●
Load monitor function (Modes 1 and Modes 2)	—	■	●
Voltage measurement display function	—	■	●
Frequency measurement display function	—	■	●
Voltage imbalance measurement display function	—	■	●
Power measurement display function	—	■	●
Power factor measurement display function	—	■	●
Electrical energy measurement display function	—	■	●
Fault clock function	—	●	●
History data record function	—	■	●
Phase sequence checking	—	■	●
Average value in a certain period of time measurement function (current and power)	—	■	■
Humorous-wave measurement	—	■	■
Over-voltage protection	—	■	●
Under-voltage protection	—	■	●
Voltage imbalance protection	—	■	●
Over-frequency protection	—	■	●
Under-frequency protection	—	■	●
Phase sequence protection	—	■	●
Inverse power potection	—	■	●
Position lock function	—	—	—

e. Overload long time-delay protection

■ Power distribution or motor protection		
Setting current	I _{r1} =	(0.4~1.0)I _n + OFF (Exit position)
	Acting property	I ≤ 1.05I _{r1} without actions in 2h I > 1.3I _{r1} with actions while it's less than 1h
Inverse-time (s) (Corresponding 2I _{r1})	Property curve	Curve 1~curve 5, could be rectified, rectified as curve 3 for ex-factory
	Curve speed	IEC255 standard, 80 level points totally, could be rectified
	Precision	±10% (intrinsic 40ms)

Note: When N-phase is 50%, protective settings are treated as 50% for N-phase. If long delay setting is 2000A, long delay setting for phase A, B and C is 2000A, and 1000A for phase N.

f. Instruction to short time-delay property

Setting current	I _{r2} =	(1.3125~15) I _{r1} + OFF (exit position)
	Acting property	≤ 0.9I _{r2} In the 2ts without actions > 1.1I _{r2} In the 2ts delay action
Inverse-time delay (s) (Corresponding 2I _{r1})	T _s =	(0.1~0.4)s (0.1s level error)
	Precision	±25% (intrinsic 40ms)
Inverse-time property		Curve is the same as overload long delay, but curve speed is 10 times faster
Short delay inverse-time thermal memory (15min)		Standard + OFF

Note: When controller is frame I (I_{nm}=2000A), rectified value of short time-delay protection is 1.3125 I_{r1}~15 I_{r1}; when controller is frame II (I_{nm}=3200A, 4000A), rectified value of short time-delay protection is 1.3125 I_{r1}~15 I_{r1} and max is 40kA; When controller is frame III (I_{nm}=6300A), rectified value of short time-delay protection is 1.3125 I_{r1}~15 I_{r1} and max is 50kA.

g. Instruction to short circuit instantaneous property

Setting current	I _{r3} =	1.3125I _n ~50kA/65kA/75kA+OFF (Exit position)
	Acting property	≤ 0.85I _{r3} In the 0.2s without actions > 1.15I _{r3} In the 0.2s with actions

Note: When controller is frame I (I_{nm}=2000A), rectified value of instantaneous protection is 1.3125I_n~50kA+OFF; when controller is frame II (I_{nm}=3200A), rectified value of instantaneous protection is 1.3125I_n~65kA+OFF; When controller is frame III (I_{nm}=6300A), rectified value of instantaneous protection is 1.3125I_n~75kA+OFF.

h. Earth fault or residual current protective property: $t = T_g \times K_g \times I_r / I$

■ Earth fault protection		
Setting current	I _f =	(0.2~0.8)I _n + OFF (with 160A as the minimum and 1200A as the maximum. OFF means it only alarms without tripping)
	Acting property	< 0.9 I _f In the 2t _g without actions ≥ 1.1 I _f In the t _g (1 ± 25%) delayed action
■ Earth fault protection		
Inverse-time (s) (Corresponding 2I _{r1})	T _G =	(0.1~0.4)s + OFF (Level difference 0.1s, OFF means it only alarms without tripping.)
	Inverse-time cutting coefficient KG	(1.5~6)s+OFF (Level difference 0.5, OFF means earth fault is definite-time)
	Precision	±10% (intrinsic 40ms)
Setting current	I _f =	(0.1~1.0)I _o + OFF (Level different 0.01A, OFF means exit position)
	Acting property	< 0.9 I _f In the 2t _g without actions ≥ 1.1 I _f In the t _g (1 ± 25%) delayed action
Delay (s)	Property curve	Curve 1~curve 5, could be rectified, rectified as curve 3 for ex-factory
	T _G =	(1.5~6)s + OFF (Level difference 0.5s, OFF means is definite-time)
	Precision	±25%

Wiring diagram of earth fault protection

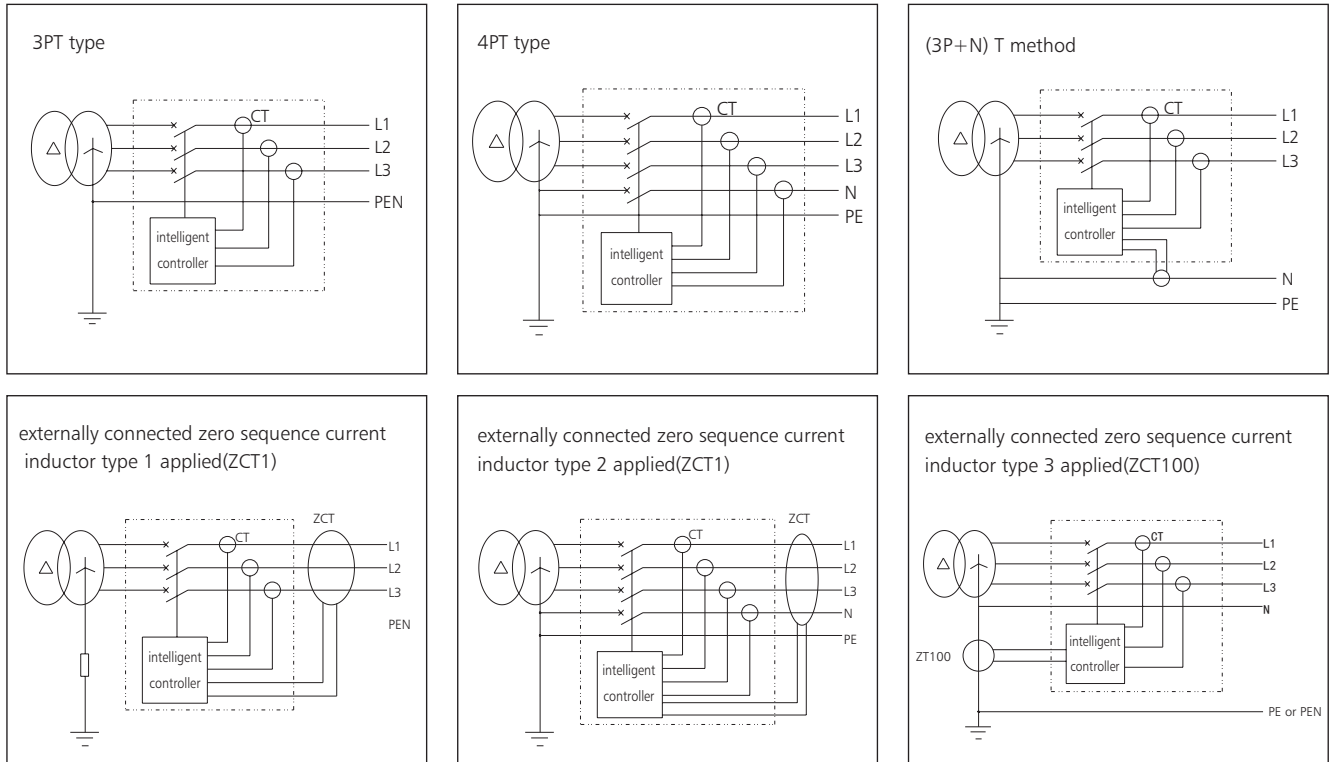

I. Load monitor protection property

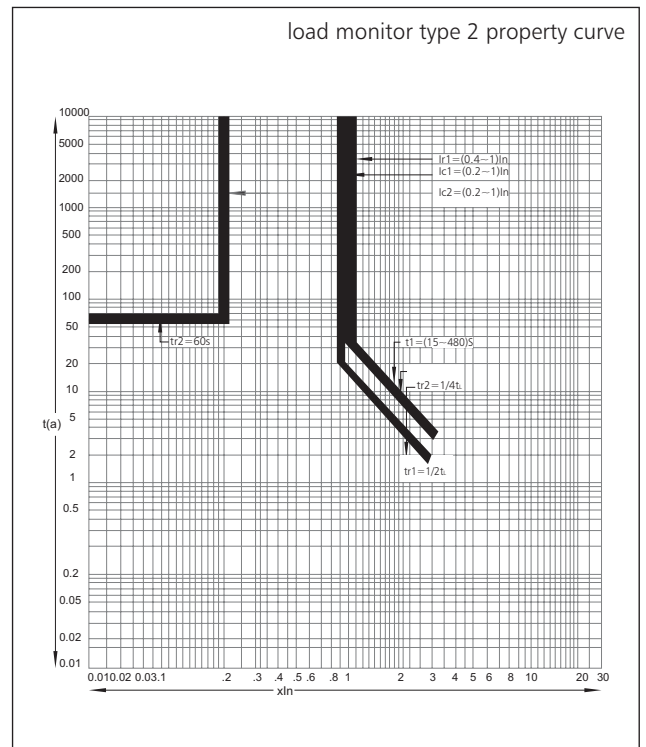
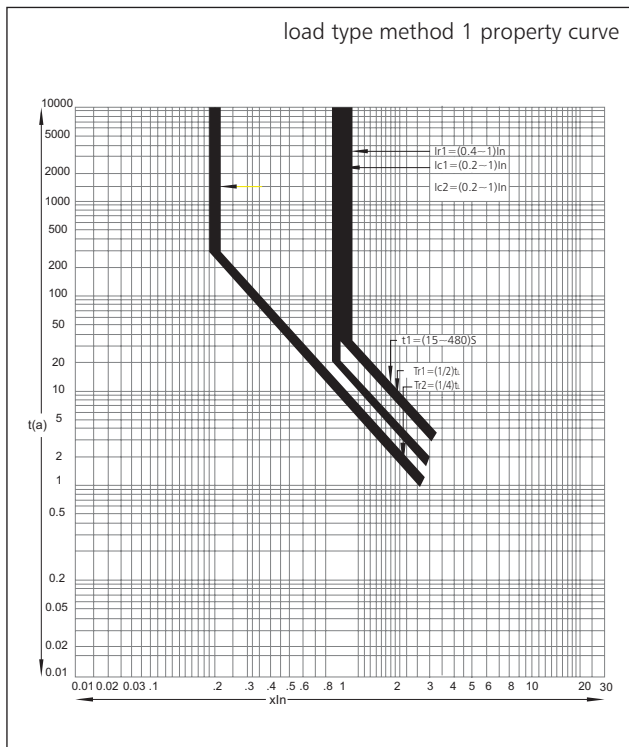

Technical parameter:

■ Load monitor type 1		
Rectified current	IC1 =	(0.2~1.0)In + OFF (OFF means exit position)
	Acting property	$\leq 1.05I_{c1}$ without action $> 1.21I_{c1}$ delay relay action
Inverse-time (s)	Property curve	The same as overload long delay
	Curve speed	Could be set separately (Setting content is the same as that of overload long delay)
Rectified current	Ic2 =	(0.2~1.0)In + OFF (OFF means exit position)
	Acting property	$\leq 1.05I_{c2}$ without action $> 1.21I_{c2}$ delayed relay
Maximal inverse-time delay (s)	Property curve	The same as overload long delay
	Curve speed	Could be set separately (Setting content is the same as that of overload long delay)

■ Load monitor type 2		
Rectified current	Ic1 =	(0.2~1.0)In + OFF (OFF means exit position)
	Acting property	$\leq 1.05I_{c1}$ without action $> 1.21I_{c1}$ delay relay action
Inverse-time (s)	Property curve	The same as overload long delay
	Curve speed	Could be set separately (Setting content is the same as that of overload long delay)
Rectified current	Ic2 =	(0.2~1.0)In + OFF (OFF means exit position)
	Acting property	$\leq 0.9I_{c2}$ without action
Fixed delay (s)		Fixed as 60s
Precision		$\pm 10\%$ (Intrinsic 40ms)
Thermal memory (30min, could be eliminated while power-off)		Standard + OFF

j. Protective property on unbalance current

Rectified current	$\delta =$	40%~100% + OFF (Level difference 0.1, OFF means exit)
	Action or alarm property	$\leq 0.9\delta$ without actions $> 1.1\delta$ delay action
Delay time (s)	$T\delta =$	(0.1~1.0)s (Level difference 0.1, OFF means exit)
Precision		$\pm 10\%$ (Intrinsic 40ms)

k. Communication networking

Make key-lock at "communication" position, connect to secondary terminals "10" and "11" through cable to achieve the communication function.

Modbus protocol networking

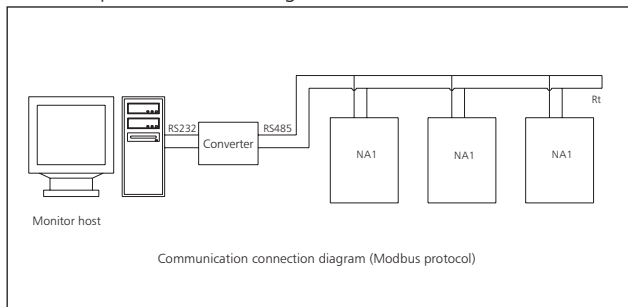

Profibus-DP protocol networking

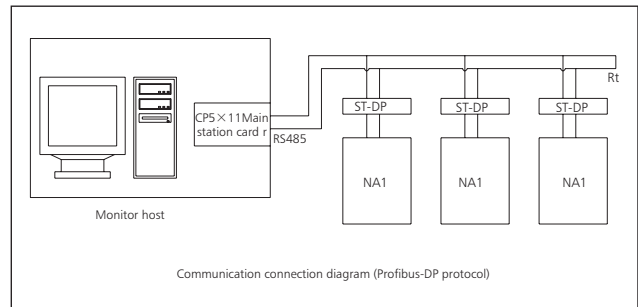

15. Accessories

15.1 Under-voltage release

Without power supply, under-voltage release can't close.

It is classified into instantaneous and time-delay type.

Delay time 1s, 3s, 5s, 7s are fixed for NA1-1000; 1s, 3s, 5s are fixed for NA1-2000, 3200, 4000, 6300.

Within 1/2 time-delay range, circuit breaker does not trip when power voltage recovers and exceeds 85%Ue.

Characteristic



Type	NA1-1000		NA1-2000, 3200, 4000, 6300	
Rated control power voltage Us(V)	AC230, 400		AC400, 230, 127	DC220, 110
Action voltage (V)	(0.35-0.7)Us			
Reliable making voltage (V)	(0.85-1.1)Us			
Reliable non-making voltage (V)	≤0.35Us			
Power loss (W)	20VA		48VA	48W

Optional configure: Auto suction type under-voltage release, and this device can substitute normal one, it can prevent mechanism from misoperation.

Make sure there is power supply on the under-voltage release, before making the circuit breaker.

15.2 Shunt release

Shunt release can realize the remote control to break the circuit breaker.

Characteristic



Type	NA1-1000		NA1-2000, 3200, 4000, 6300	
Rated control power voltage Us(V)	AC230, 400	DC220, 110	AC400, 230, 127	DC220, 110
Work voltage	(0.7-1.1)Us			
Power loss	56VA	250W	300VA	132W 70W
Breaking time	(50±10)ms	(50±10)ms	(30~50)ms	(30~50)ms

Forbid making the power for long time to avoid the shunt release being damaged.

15.3 Closing electromagnet

After the motor finishing the energy storage, closing release can instantly close the circuit breaker.

Characteristic



Type	NA1-1000		NA1-2000, 3200, 4000, 6300	
Rated control power voltage Us(V)	AC230, 400	DC220, 110	AC400, 230, 127	DC220, 110
Work voltage (V)	(0.85-1.1)Us			
Power loss (W)	56VA	250W	300VA	132W 70W
Closing time	(50±10)ms	(50±10)ms	≤70ms	≤70ms

Forbid making the power for long time to avoid the closing release being damaged.

15.4 Motor-driven energy-storage mechanism

With the function of motor-driven energy storing and auto restoring energy after closing the circuit breaker, the mechanism can ensure closing the circuit breaker instantly after breaking the circuit breaker. Manual energy-store is available.

Characteristic



Type	NA1-1000		NA1-2000, 3200, 4000, 6300	
	AC230, 400	DC220, 110	AC400, 230	DC220, 110
Rated control power voltage Us(V)	(0.85-1.1)Us			
Work voltage (V)	(0.85-1.1)Us			
Power loss (W)	90W	90W	85/110/150W	85/110/150W
Energy-storage time	<4s	<4s	≤5s	≤5s
Operation frequency	No more than 3 times per minute			

15.5 Auxiliary contact NO

Standard model: 4NO(normal open)/4NC(normal close) and 6NC(normal close).

Characteristic



Type	NA1-1000			NA1-2000~6300		
	AC230	AC400	DC220	AC230	AC400	DC220
Rated voltage (V)						
conventional free-air thermal current Ith (A)	10	6	0.5	6	6	6
Rated control capacity	300VA	100VA	60W	300VA	300VA	60W

NA1-1000			NA1-2000~6300		
Category	Voltage	Current	Category	Voltage	Current
AC-15	AC230V	1.3A	AC-15	AC230V	1.3A
	AC400V	0.25A		AC400V	0.75A
DC-13	DC110V	0.55A	DC-13	DC110V	0.55A
	DC220V	0.27A		DC220V	0.27A

15.6 Doorcase

Installed on the door of the distribution cubicle, for sealing the distribution cubicle and making the protection class to IP40(fixed type and drawout type).

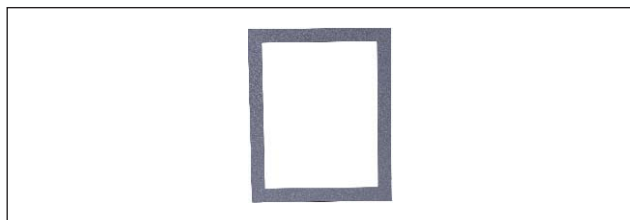

15.7 Phases barrier (Optional)

Installed between the busbars to increase the creepage distance.



15.8 Operation pushbutton lock (Optional)

Used for locking the break pushbutton and the close pushbutton. (Padlock is prepared by users)



15.9 Transparent shield (NA1-2000) (Optional)

Installed on the doorcase of the cubicle's small door, make the protection class to IP54. It is suitable for the fixed, drawout type circuit breaker and the load switch.



15.10 Off position locking mechanism

When the circuit breaker is disconnected, padlock can be used to lock it after pulling out the lock lever, then the circuit breaker can't be "Test" or "connected" position. (Padlock is prepared by users)

15.11 Key lock

Lock the circuit breaker on the OFF position, then the circuit breaker can't be closed.

Locks and keys will be provided by us.

Separate lock and key is matched with one set of the circuit breaker.

Three same locks and two same keys are matched with three circuit breaker.

Note: Before pulling out the key, the break pushbutton should be pressed first, rotate the key anticlockwise, then pull it out.

★ NA1 Install the locking system

1. Components of the locking system:



2. Installation sequence:

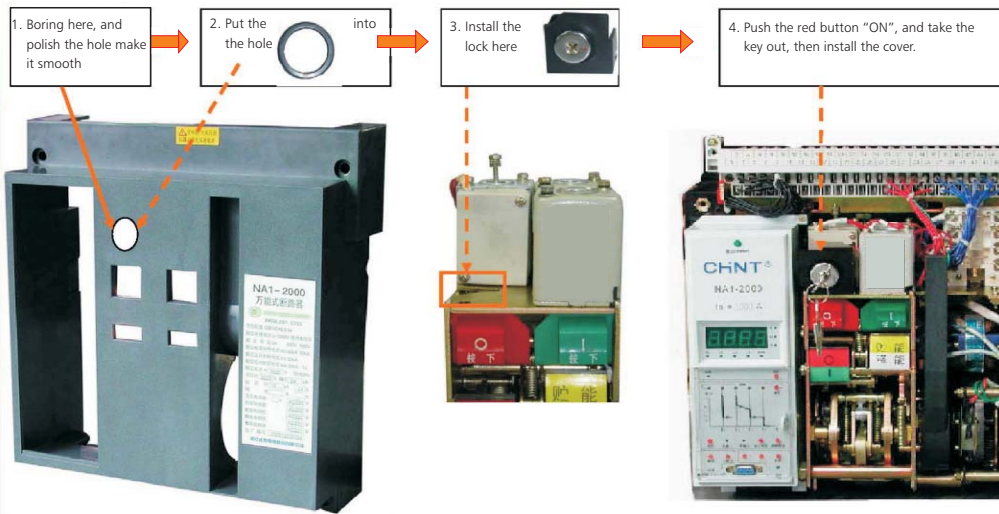

15.12 Cable mechanical interlock

It can realize the interlock of two horizontal or vertical-installed, three poles or four poles, drawout type or fixed type circuit breaker.

- a. If need bend the cable, make sure the radian is more than 120°.
- b. Check and make sure enough lubricating oil of the cable.
- c. The maximum distance between two interlock circuit breakers is 1.5m.

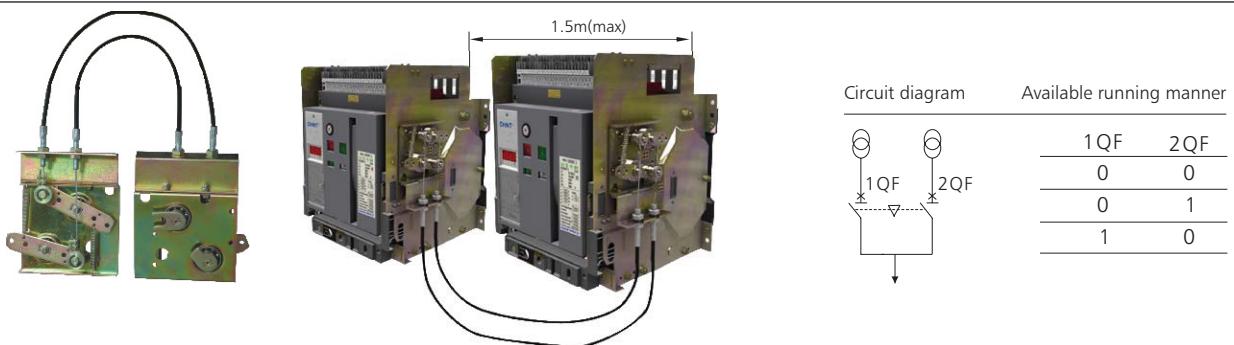

Notes: a. when the steel cable needs to be bent, enough transition arc should be reserved to guarantee flexible movement of steel cable;
b. check the steel cable and make sure there is enough lubricant in the steel cable to guarantee flexible movement of steel cable.

15.13 Connecting-rod type mechanical interlock

Three vertical-installed three-poles or four-poles, drawout-type or fixed type circuit breakers realize the interlock between one breaker with another two different-state breakers.

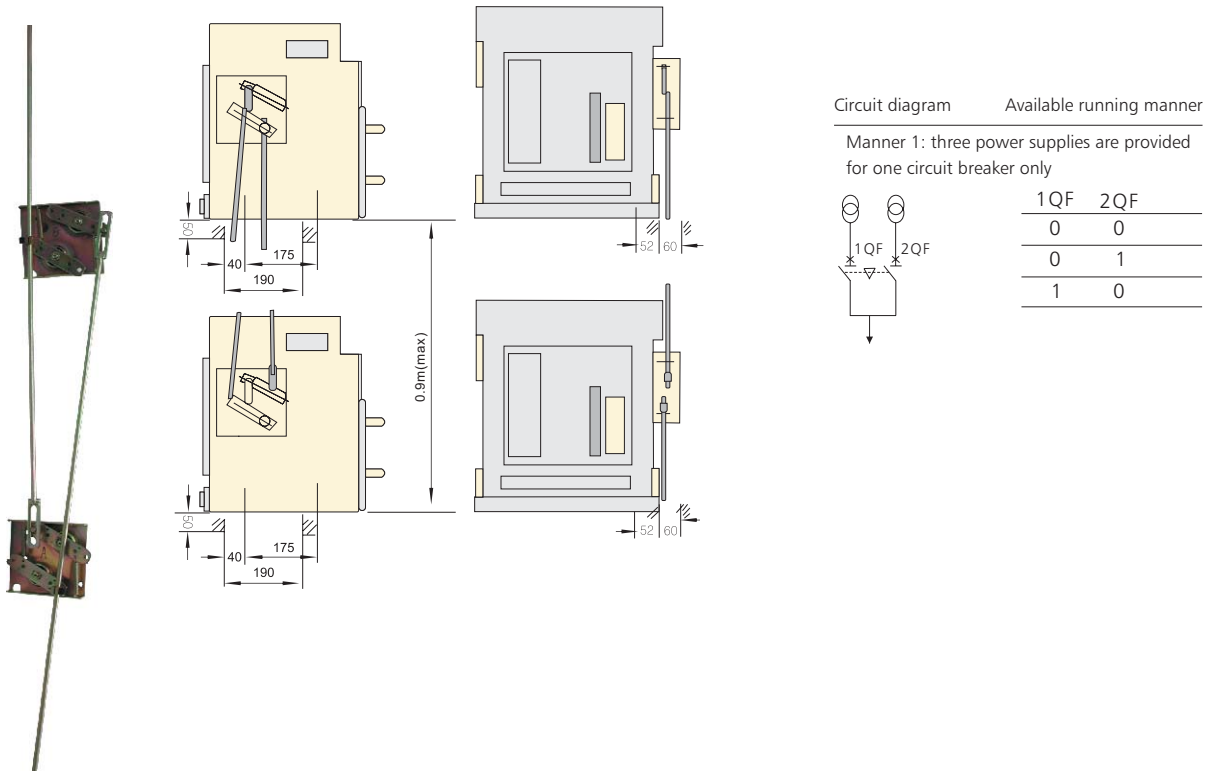

16. Regular malfunction and solutions

Fault description	Reasons analysis	Maintenance method
Tripping of circuit breaker	Over load tripping (IL indicator flashing)	<ol style="list-style-type: none"> 1. Check the breaking current value and operation time of intelligent release. 2. Analyze the load and electric network, exclude the overload if it happens. 3. Match the actual operating current with long time-delay current setting value. 4. Press the reset button to reclose the breaker
	Short circuit tripping ("Is" or "Ii" indicator flashing)	<ol style="list-style-type: none"> 1. Check the breaking current value and operation time of intelligent release. 2. Exclude the short circuit fault if it happens 3. Check the setting value of intelligent release 4. Check the normal state of breaker 5. Press the reset button to reclose the breaker
	Earthing fault tripping (IG indicator flashing)	<ol style="list-style-type: none"> 1. Check the breaking current value and acting time of intelligent release. 2. Exclude the earthing fault if that happens. 3. Match the fault current setting value with the actual protection. 4. Press the reset button to reclose the breaker.
	Under-voltage release fault: 1. Rated working voltage is less than 70%Ue 2. Fault of control unit	<ol style="list-style-type: none"> 1. Check the power is on or not 2. Check the power voltage of under-voltage release, it shouldn't be less than 85%Ue. 3. Replace the control unit of under-voltage release
The breaker can't be closed	Mechanical interlock acting	Check the working state of two circuit breakers fixed with mechanical interlock
	Intelligent release don't reset (panel is raised)	Press the reset button to reclose the breaker
	Secondary circuit of drawerout-type breaker isn't connected	Make the breaker to "making" position ("click" sound will be heard)
The breaker can't be closed	Breaker hasn't stored energy	Check the secondary circuit: <ol style="list-style-type: none"> 1. Power voltage of motor shouldn't less than 85%Ue. 2. Check the storage mechanism, replace it if necessary.
	Mechanical interlock acting leads to locking of breaker	Check the working state of two circuit breakers fixed with mechanical interlock
Tripping after closing the circuit breaker (Fault indicator flashing)	Closing electromagnet: 1. Rated control voltage is less than 85%Us; 2. Closing electromagnet is damaged	<ol style="list-style-type: none"> 1. Power voltage of closing electromagnet shouldn't less than 85%Us. 2. Replace the electromagnet.
	Tripping immediately: 1. Short circuit current is closed 2. Delay tripping because of transient current is high when closing; 3. Overload current is closed	<ol style="list-style-type: none"> 1. Check the breaking current value and operation time of intelligent release; 2. Exclude the short circuit fault if it happens; 3. Exclude overload fault 4. Check the normal state of breaker 5. Modify the current setting value of intelligent release 6. Press the reset button to reclose the breaker
Circuit breaker can't be opened	The breaker can't be opened manually 1. There is fault with mechanical operating mechanism	1. Check the mechanism, if there is fault happened.
	The breaker can't be opened by motor remotely 1. There is fault with mechanical operating mechanism 2. Power voltage of shunt release is less than 70%Us; 3. Shunt release is damaged	<ol style="list-style-type: none"> 1. Check the mechanism, if there is fault happened. 2. Check the Power voltage of shunt release is less than 70%Us or not 3. Replace shunt release

Fault description	Reasons analysis	Maintenance method
Circuit breaker can't store energy	Manual storage can't be realized	Mechanical fault with the energy-storage device
	Motor storage can't be realized 1.Power voltage of motor energy-stored device is less than 85%Us; 2.There is mechanical fault with energy-storage device	1. Power voltage of motor energy-stored device shouldn't less than 85%Us 2. Mechanical fault with the energy-storage device
Handle of drawerout-type circuit breaker can't be drawn in or out	1. There is padlock at the "opening" position 2. Slideway or breaker body isn't pulled into its position	1.Take away the padlock 2.Pull the slideway or breaker body into its position
Drawerout-type breaker can't be drawn out at the "opening" position	1.Handle isn't pulled out 2.Breaker is not totally at the "opening" position	1.Pull out the handle 2.Keep the circuit breaker totally at "opening" position
Drawerout-type breaker can't reach the "making" position	1. Something drop into the drawer base, and lock the mechanism or mechanism fault happens. 2. Breaker body not match with the frame-size rated current of drawer base	1. Check and clean the drawer base, or contact with manufacturer 2. Match the body with relevant drawer base
No display on intelligent release panel	1. Release isn't connected with power 2.There is fault with release	1.Check the power is connected or not 2.Cut off the power, then connect again. Otherwise contact with manufacturer
	Closing electromagnet: 1. Rated control voltage is less than 85%Us; 2. Electromagnet is damaged	1. Check the electromagnet power voltage shouldn't be less than 85%Us. 2. Replace the closing electromagnet.
Fault indicator still flashing after pressing the clear button	Fault happened with intelligent release	Cut off the power, then connect again. Otherwise contact with manufacturer

NA1-1000 Ordering specification

Customer: _____ Tel: _____ Date: _____
Quantity: _____

Model		NA1-1000		
Rated current In(A)		<input type="checkbox"/> 200 <input type="checkbox"/> 400 <input type="checkbox"/> 630 <input type="checkbox"/> 800 <input type="checkbox"/> 1000		
Installation mode		<input type="checkbox"/> Drawout type <input type="checkbox"/> Fixed type		
Number of poles		<input type="checkbox"/> Three poles <input type="checkbox"/> Four poles		
Intelligent Controller	□ M type Standard	Default configuration	Conventional setting before delivery: $I_R=1I_{nR}$, 30s, $I_{sd}=8I_{nR}$, $T_{sd}=0.4s$; $I_i=12I_{nR}$; $I_g=OFF$ $t_g=0.4s$	
			Long time-delay protection I_R	Current setting: _____ I_n (0.4, 0.5, 0.6, 0.7, 0.8, 0.9, 1, OFF) Time setting: _____ s (30, 60, 120, 240)
			Short circuit short time-delay protection I_{sd}	Current setting: _____ I_R (3, 4, 5, 6, 7, 8, 10, OFF) Time setting: _____ s (0.2, 0.4)
			Short circuit instantaneous protection I_i	Current setting: _____ I_n (3, 4, 6, 8, 10, 12, 15, OFF)
			Earthing protection I_g	Current setting: _____ I_n (0.2, 0.3, 0.4, 0.5, 0.6, 0.7, 0.8, OFF Min100A) Time setting: _____ s (0.2, 0.4, 0.6, 0.8)
				Protection data setting: LED display; Test function; Fault recall; Self-diagnose function; MCR making and breaking function; Fault breaking alarm
	Optional configuration	<input type="checkbox"/> Current transformer earthing protection(3P+N model)		
	□ H type Comm-unication	Default configuration	Conventional setting before delivery: $I_R=1I_{nR}$, 30s, $I_i=6I_{nR}$, $I_{sd}=8I_{nR}$; $T_{sd}=0.4s$; $I_i=12I_{nR}$; $I_g=OFF$ $t_g=0.4s$	
			Long time-delay protection I_R	Current setting: $(0.4\sim 1)I_n + (\text{step } 1A)$ Time setting $(1.5I_R)$: (15, 30, 60, 120, 240, 360, 480, 600, 720, 840, 960) s
			Short circuit short time-delay protection I_{sd}	Current setting: $(1.5\sim 15)I_R + OFF + (\text{step } 1A)$ Time setting: $(0.1\sim 0.4)s + (\text{step } 0.1)$
Instantaneous protection I_i			Current setting: $(1.0\sim 20)I_n + OFF + (\text{step } 1A)$	
Earthing protection I_g			Current setting: $(0.2\sim 1.0)I_n + (\text{step } 1A)$ Time setting: $(0.1\sim 1)s + (\text{step } 0.1)$	
			LCD display; LED indication; Keyboard operation; Eight fault records; Self-diagnose function; Operation records; Clock function; Peak current records; Test function; Four-phase current and earthing current measuring; Heat capacity; Earthing alarm; Neutral phase protection; Unbalanced current protection; MCR protection; Eight alarm records.	
Optional configuration	Modbus communication; Profibus-DP communication; Voltage measuring; Frequency measuring power measuring; Electric energy measuring; Unbalanced voltage measuring; Phase sequence detection; Power factor measuring; Over voltage protection; Under protection; Phase protection.			
Other	Power of controller: <input type="checkbox"/> AC400V <input type="checkbox"/> AC230V <input type="checkbox"/> DC220V <input type="checkbox"/> DC110V <input type="checkbox"/> DC24V			
Electrical accessories	Energy storage motor	Under-voltage release: <input type="checkbox"/> Instantaneous <input type="checkbox"/> delay _____ s(1,3,5,7s) <input type="checkbox"/> AC400V <input type="checkbox"/> AC230V		
		Shunt release: <input type="checkbox"/> AC400V <input type="checkbox"/> AC230V <input type="checkbox"/> DC220V <input type="checkbox"/> DC110V		
		Closing electromagnet: <input type="checkbox"/> AC400V <input type="checkbox"/> AC230V <input type="checkbox"/> DC220V <input type="checkbox"/> DC110V		
		Energy Storage Motor: <input type="checkbox"/> AC400V <input type="checkbox"/> AC230V <input type="checkbox"/> DC220V <input type="checkbox"/> DC110V		
		Auxiliary contact: <input type="checkbox"/> 4 groups changeover contacts with common point <input type="checkbox"/> 6 groups changeover contacts with common point		
Busbar	<input type="checkbox"/> Horizontal Connection			
Special requirements	<input type="checkbox"/> Phases barrier <input type="checkbox"/> Steel cable interlocking <input type="checkbox"/> Vertical Connection			
	<input type="checkbox"/> Three locks with two keys <input type="checkbox"/> One lock with one key <input type="checkbox"/> Two locks with one key			

Note: 1) Please mark "√" or fill figure in the relative "□" if no mark, we will provide according to conventional.

Note: 2) The operational function of the intelligent controller and special requirements require additional costs



NA1-1000

NA1-2000~6300 Ordering specification

Customer: _____ Tel: _____ Date: _____
Quantity: _____

Model	NA1-2000	NA1-3200	NA1-4000	NA1-6300
Rated current In (A)	<input type="checkbox"/> 630 <input type="checkbox"/> 800 <input type="checkbox"/> 1000 <input type="checkbox"/> 1250 <input type="checkbox"/> 1600 <input type="checkbox"/> 2000	<input type="checkbox"/> 2000 <input type="checkbox"/> 2500 <input type="checkbox"/> 3200	<input type="checkbox"/> 4000	<input type="checkbox"/> 4000 <input type="checkbox"/> 5000 <input type="checkbox"/> 6300(no four poles)
Installation mode	<input type="checkbox"/> Drawout type <input type="checkbox"/> Fixed type (Note: no fixed type when In > 4000A)			
Number of poles	<input type="checkbox"/> Three poles <input type="checkbox"/> Four poles			
Intelligent Controller	<input type="checkbox"/> M type Standard (Default configuration)	Protection function 1. <input type="checkbox"/> Ir1 overload long delay Ir2 short-circuit short delay inverse time + definite time Ir3 transient short-circuit, Ir4 single-phase grounding 4-section protection 2. <input type="checkbox"/> Ir1 overload long delay, Ir2 definite time short-circuit short delay, Ir3 transient short-circuit, Ir4 single-phase grounding 4-section protection	Auxiliary functions 1. Ammeter function 2. Self-diagnostic function 3. Tuning function 4. Test function 5 Display function	Optional function 
	<input type="checkbox"/> 3M type Multifunctional (Optional configuration)	1. <input type="checkbox"/> Ir1 overload long delay Ir2 short-circuit short delay inverse time + definite time Ir3 transient short-circuit, Ir4 single-phase grounding 4-section protection 2. <input type="checkbox"/> Ir1 overload long delay, Ir2 definite time short-circuit short delay, Ir3 transient short-circuit, Ir4 single-phase grounding 4-section protection		<input type="checkbox"/> Voltage display <input type="checkbox"/> Frequency display <input type="checkbox"/> Power Factor show <input type="checkbox"/> Active power display <input type="checkbox"/> Load monitoring function Note: For the specific optional function, refer to List of controller functions in the sample (The coast of optional functions will be calculated additionally).
	<input type="checkbox"/> 3H-type Communication type (Optional configuration)	1. <input type="checkbox"/> Ir1 overload long delay Ir2 short-circuit short delay inverse time + definite time Ir3 transient short-circuit, Ir4 single-phase grounding 4-section protection 2. <input type="checkbox"/> Ir1 overload long delay, Ir2 definite time short-circuit short delay, Ir3 transient short-circuit, Ir4 single-phase grounding 4-section protection 3. <input type="checkbox"/> with PROFIBUS-DP communication protocol <input type="checkbox"/> with MODBUS communication protocol		
	Notes: Protection function Settable range and conventional factory tuning	Ir1 long delay current setting range: (0.4 to 1) In Overload 1.5Ir1 action time setting range: 15,30,60 480s Ir2 short delay current setting range: (1.3125 to 15) Ir1; short delay action time (0.1 ~ 0.4) s Ir3 instantaneous current setting range: 1.3125In ~ 50kA/65kA/75kA ! Conventional factory tuning: the, 12In [Note: 3M, 3H for (1.5In 50kA/65kA/75kA)] Ir4 earthing protection current setting range: (0.2 to 0.8) In; the earthing protection time setting range: (0.1 to 0.4) s ! Conventional factory setting: 0.5 In; OFF	! Conventional factory tuning: overload long delay 1.0In ! Conventional factory tuning: overload 1.5Ir1; action 15s ! Conventional factory setting: short delay current 8Ir1 of; ! Conventional factory tuning: Short delay action time 0.4s [Note: 3M, 3H for (1.5 to 15) Ir1]	
Electrical accessories	Controller power <input type="checkbox"/> AC380V, <input type="checkbox"/> AC400V, <input type="checkbox"/> AC220V, <input type="checkbox"/> AC230V, <input type="checkbox"/> AC127V, <input type="checkbox"/> DC220V, <input type="checkbox"/> DC110V (Optional)			
	Undervoltage release (default configuration) <input type="checkbox"/> AC380V, <input type="checkbox"/> AC400V, <input type="checkbox"/> AC220V, <input type="checkbox"/> AC230V, <input type="checkbox"/> AC127V, <input type="checkbox"/> DC220V, <input type="checkbox"/> DC110V, <input type="checkbox"/> Order ___ V, <input type="checkbox"/> Non-undervoltage (Optional)			
	<input type="checkbox"/> Instantaneous <input type="checkbox"/> delay, s; <input type="checkbox"/> Resistance capacity loss release delay (1,3,5) s, and optional non-adjustable (Optional)			
	Shunt release <input type="checkbox"/> AC380V, <input type="checkbox"/> AC400V, <input type="checkbox"/> AC220V, <input type="checkbox"/> AC230V, <input type="checkbox"/> AC127V, <input type="checkbox"/> DC220V, <input type="checkbox"/> DC110V (Optional)			
	Closing electromagnet <input type="checkbox"/> AC380V, <input type="checkbox"/> AC400V, <input type="checkbox"/> AC220V, <input type="checkbox"/> AC230V, <input type="checkbox"/> AC127V, <input type="checkbox"/> DC220V, <input type="checkbox"/> DC110V (Optional)			
	Electric motor <input type="checkbox"/> AC380V, <input type="checkbox"/> AC400V, <input type="checkbox"/> AC220V, <input type="checkbox"/> AC230V, <input type="checkbox"/> AC127V, <input type="checkbox"/> DC220V, <input type="checkbox"/> DC110V (Optional)			
Special requirements	Interlock device (surcharge) Mechanical linkage: <input type="checkbox"/> Link interlock <input type="checkbox"/> Cable interlock Door interlock: <input type="checkbox"/> Switch body position door interlock <input type="checkbox"/> Switch on/off state door interlock (drawer-type) (Optional)			
	Accessories (surcharge) Button lock: <input type="checkbox"/> Panel products on/off button lock Key lock: <input type="checkbox"/> 1 lock 1 key <input type="checkbox"/> 2 locks 1 key <input type="checkbox"/> 3 locks 1 key <input type="checkbox"/> 3 locks 2 keys <input type="checkbox"/> 5 locks 2 keys <input type="checkbox"/> Special custom ___ lock ___ key External transformer: <input type="checkbox"/> External N phase transformer [(3P+N)T type, [No 3P+N:NA1-4000/3(In:4000A), NA1-6300(In:6300A)] (Optional) <input type="checkbox"/> External leakage zero sequence current transformer (E mode) <input type="checkbox"/> External ground current transformer (W) Module: <input type="checkbox"/> PSU-1 Power module <input type="checkbox"/> RU-1 relay module <input type="checkbox"/> ST-DP protocol converting module <input type="checkbox"/> Position signaling devices (<input type="checkbox"/> Connected <input type="checkbox"/> Test <input type="checkbox"/> Unconnected) <input type="checkbox"/> Mechanical counting device			
	The main circuit connection <input type="checkbox"/> Horizontal connection (default) <input type="checkbox"/> Vertical connection (with L vertical bus-bar) <input type="checkbox"/> Rotation busbar horizontal connection (Drawer In ≤ 3200) <input type="checkbox"/> Rotation busbar vertical connection (drawer-type In ≤ 3200) (Optional)			

Note: The casing current, rated current and auxiliary control voltage must be specified when ordering!

Note: 1) Please mark "√" or fill figure in the relative "□" if no mark, we will provide according to conventional.

Note: 2) The operational function of the intelligent controller and special requirements require additional costs.

Tel.:0577-6287777-6213 Fax :0577-6287777-6288



NA1-6300



NA1-4000



NA1-3200



NA1-2000

Configuration instructions

1. NA1-2000~6300 fundamental configurations

a. Motor-driven:

Under-voltage instantaneous release;
Shunt release;
Closing electromagnet;
4 suits of transform contact;
Motor driven operating mechanism;
M-type Intelligent Controller;
Horizontal wiring of main circuit;
Doorcase;
Element of main circuit;
Operating instructions of M-type Intelligent Controller
Operating instructions of Air Circuit Breaker;
Packing box;
Drawer seat (Drawout type)

b. Manual:

Under-voltage instantaneous release;
4 suits of transform contact;
M-type Intelligent Controller;
Horizontal wiring of main circuit;
Doorcase;
Element of main circuit;
Operating instructions of M-type Intelligent Controller
Operating instructions of Air Circuit Breaker;
Packing box;
Drawer seat(Drawout type)

3. NA1-2000~6300 operational configuration (additional costs)

Nonadjustable under voltage delayed release (1s, 3s, 5s);
Connecting-rod type mechanical interlock (for drawout type);
Wire-cable mechanical interlock; Button lock; Key lock;
Door interlock/Locking device;
External current transformer earthing protection; Vertical busbar;
Rotating busbar ($I_N \leq 3200$);
3NO (normal open) and 3NC (normal close) contacts;
4NO and 4NC contacts; 5 groups changeover contacts;
3 groups changeover contacts; H type intelligent controller;
Position signal; Counter; Protecting cover (NA1-2000);
Double power controller.

2. NA1-1000 fundamental configurations

a. Motor-driven:

Under-voltage instantaneous release;
Shunt release;
Closing electromagnet;
Motor driven operating mechanism;
4 normal open and 4 normal close auxiliary contacts;
M-type Intelligent Controller;
Closing and breaking push button lock;
Horizontal wiring of main circuit;
Doorcase;
Element of main circuit;
Operating instructions of Air Circuit Breaker;
Packing box;
Drawer seat(Drawout type)

b. Manual:

Under-voltage instantaneous release;
4 normal open and 4 normal close auxiliary contacts;
M-type Intelligent Controller;
Horizontal wiring of main circuit;
Closing and breaking push button lock;
Doorcase;
Element of main circuit;
Operating instructions of Air Circuit Breaker;
Packing box;
Drawer seat(Drawout type)

4. NA1-1000 operational configuration (additional costs)

Under voltage delayed release; wire-cable mechanical interlock;
key lock; External current transformer earthing protection;
Vertical busbar; 6 groups changeover contacts;
H type intelligent controller; Phases barrier position signal.

KLINKMANN

Helsinki

tel. +358 9 540 4940
info@klinkmann.fi

St. Petersburg

tel. +7 812 327 3752
klinkmann@klinkmann.spb.ru

Moscow

tel. +7 495 641 1616
moscow@klinkmann.spb.ru

Yekaterinburg

tel. +7 343 287 19 19
yekaterinburg@klinkmann.spb.ru

Samara

tel. +7 846 273 95 85
samara@klinkmann.spb.ru

Kiev

tel. +38 044 495 33 40
klinkmann@klinkmann.kiev.ua

Riga

tel. +371 6738 1617
klinkmann@klinkmann.lv

Vilnius

tel. +370 5 215 1646
post@klinkmann.lt

Tallinn

tel. +372 668 4500
klinkmann.est@klinkmann.ee

Minsk

tel. +375 17 200 0876
minsk@klinkmann.com