



Terminal blocks

G - Distribution terminal blocks

Summary

1. Distribution bars

Screw clamp ground terminal block	384
Connection with 18 x 3 mm collector bar	385
Bars with base for ground wire	386
Busbar clamp	387

2. Distribution terminal blocks

Phases - Ground assemblies	388
Single pole distribution blocks	390
Three pole distribution blocks	392
Four pole distribution blocks	392

Ground terminal block

Screw clamp

↳ DIN 1 (EN 50035, DIN 46277/1, NFL 63018)

E 10/13.P

Spacing 13 mm (.512")

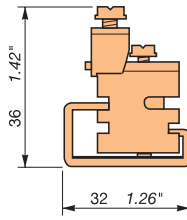

Type	Part number	Type	Part numbers
1 Screw clamp Can also be used as end stop	E 10/13.P		1SNA 162 855 R2300

Characteristics

Wire size	Screw clamp	Rigid Flexible	NFC	DIN	UL	CSA	NFC	DIN	UL	CSA
			0-16 mm ²	16-8 AWG						
			0-10 mm ²	16-8 AWG						
Rated current	A		85							
Rated wire size	mm ² /AWG		10 mm ²		8 AWG					

Other characteristics

Wire strip. length	Recomm. screwdriver	Recomm. torque	Protection	Wire strip. length	Recomm. screwdriver	Recomm. torque	Protection
12 mm .47"	6.5 mm .25"						

Accessories

	Type	Part numbers	Type	Part numbers
1 Rail ↳ 32 x 15	PR1 Z2	1SNA 163 050 R0400		
2 Label with symbol "ground"	IDTBM	1SNA 167 357 R0400		

Distribution of polarities

If the distribution bar is longer than 1 foot (300 mm) use an intermediate end stop for support. In this case the precut bar passages need to be punched out of the end stop.

- Grey ↳ **BADH** 1SNA 116 900 R2700
- Grey ↳ **BAEH** 1SNA 116 934 R0400

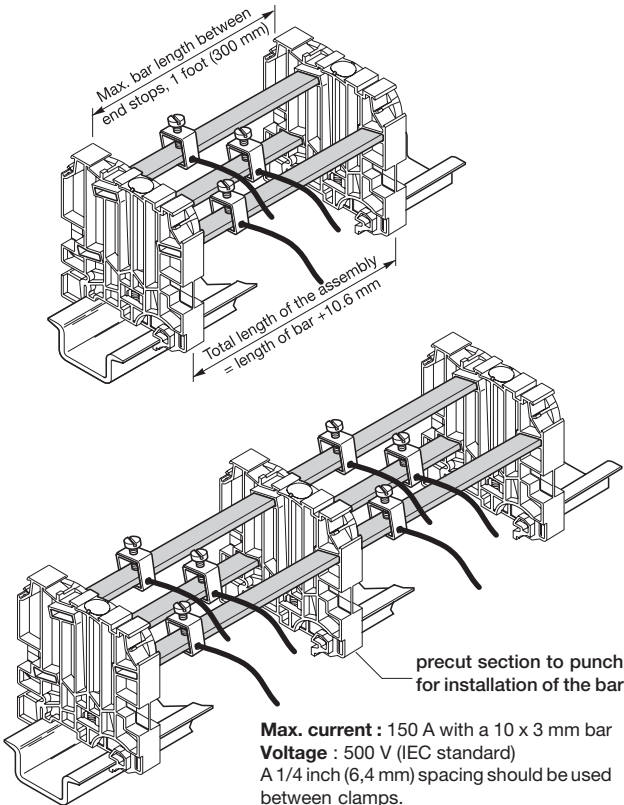

Description	Types	Part numbers
Copper bar	BO3 1000 x 10 x 3 mm	1SNA 164 406 R2400
Wire clamp	SFB1 20-2 AWG (0.5-35 mm ²)	1SNA 163 860 R0500
Wire clamp	SFB2 6-2 AWG (16-35 mm ²)	1SNA 168 956 R0600

This end stop is also recommended :

1 - For use with neutral switch blocks series "NT"

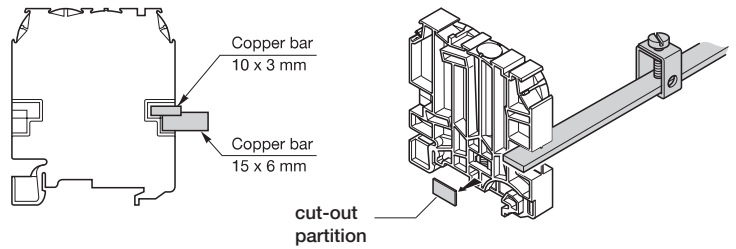

2 - For use with separators SCFCV4 with protection cover

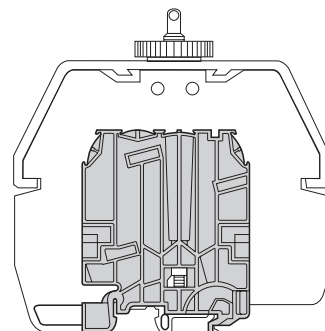

Connection with 18 x 3 mm collector bar

↳ DIN 3

Shield terminals for collector bar

- Mounting on 18 x 3 mm collector bar
- Easy shield connection to a collector bar
- Brass with nickel coating clamp with a steel spring to make contact without damaging the shield
- Shield terminals available in 4 versions (shield diameter from 1,5 to 24 mm)
- Not designed for wire connection
- Mounting : place the shield of the stripped cable on the collector bar. Hold the terminal on the shield, press and snap the terminal onto the collector bar. As soon as the terminal is released, contact is made on the bar through the spring pressure.

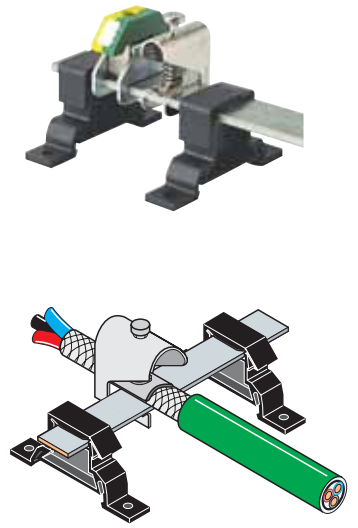
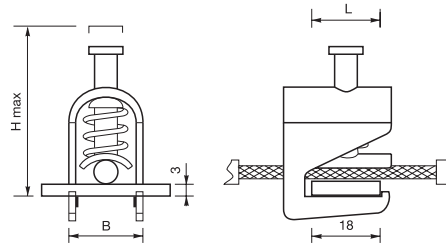

Characteristics

Shield diameter	B (mm)	L (mm)	H max (mm)	Spring force (N)	Description	P/N
1,5 - 6,5	10	25	40	8 - 13	SFB.B1	1SNA 205 170 R1400
5 - 11	17	25	47	22 - 31	SFB.B2	1SNA 205 171 R0100
10 - 17	23	25	63	32 - 58	SFB.B3	1SNA 205 172 R0200
16 - 24	30	25	78	37 - 53	SFB.B4	1SNA 205 173 R0300

Terminals for collector bar

- 35 mm² terminal for 18 x 3 mm collector bar.
- Stainless steel clamp and screw
- Insulating part in polyamid 6,6 without halogen
- Possibility to print 3 characters per marker
- If a separate ground is required, isolated mounting on rail should be made through a bar holder P/N 1SNA 205 176 R0600

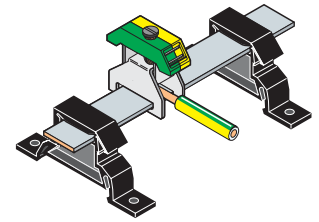
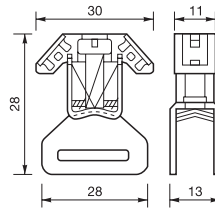

SFB.P 1SNA 205 174 R0400

Bar holder (isolated from ground)

- To be screwed on plate or snapped onto DIN 3 rail
- Thermoplastic material, black colour
- Spacing : 12 mm .473"

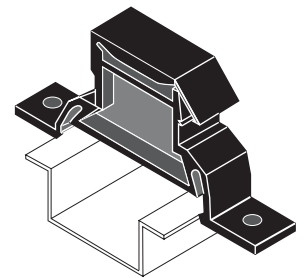
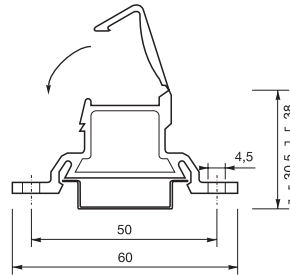

DSPBO.PI 1SNA 205 176 R0600

Collector bar

- Electroplated copper with tin coating 18 x 3 x 1000 mm

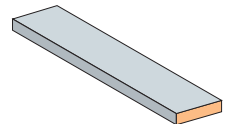

BO 318 1SNA 205 175 R0500

Bar holder (connected to the mounting rail)

- To be snapped onto DIN 3 rail.
- Thermoplastic material, black colour.
- Tinned coated steel socket
- Spacing : 10 mm .394"

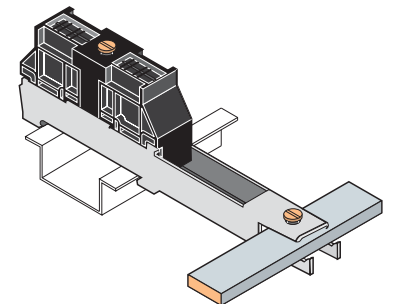
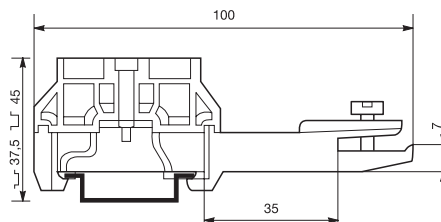

DSPBO.P 1SNA 205 177 R0700

Bars with base for ground wire

DIN 3



- PR3.Z2 35 x 7,5 x 1 1SNA 174 300 R1700
 - PR4 35 x 15 x 2,3 1SNA 168 500 R1200
 - PR5 35 x 15 x 1,5 1SNA 168 700 R2200
- Other rails : see section on accessories.

DBTI

7 outputs

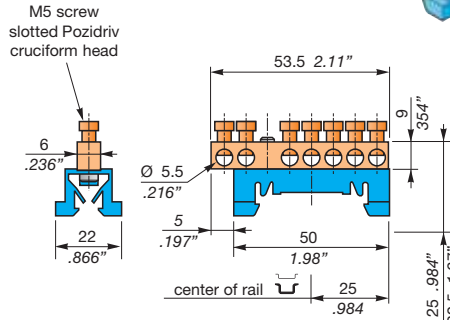
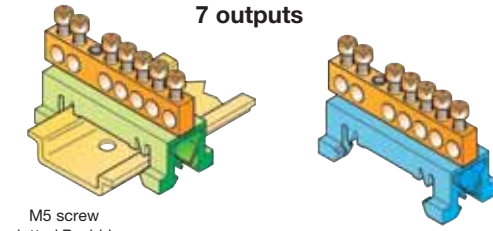

Blue or green base - Mounting on DIN 3 rail

12 outputs

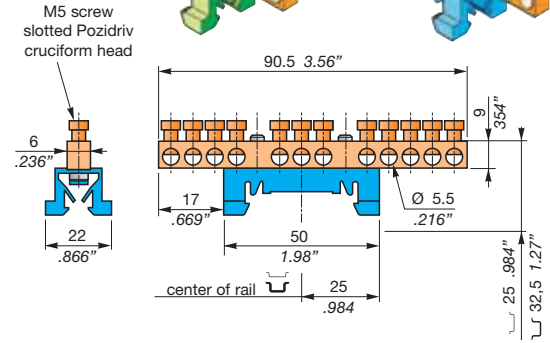
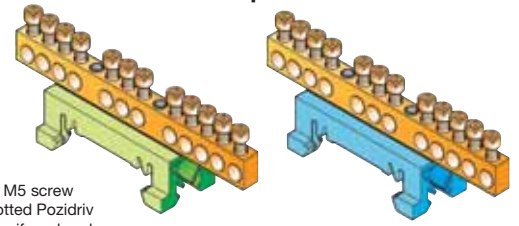

Blue or green base - Mounting on DIN 3 rail

Type	P/N	CE	Type	P/N	CE
7 outputs blue base DBTI	1SNA 356 100 R1500		12 outputs blue base DBTI	1SNA 356 102 R0300	
7 outputs green base DBTI	1SNA 356 101 R0200		12 outputs green base DBTI	1SNA 356 103 R0400	

Characteristics

	IEC	UL	CSA	IEC	UL	CSA
Connection - Screw clamp - Max. wire size	7 outputs 10 mm ²			12 outputs 10 mm ²		
Torque on screw Screw	1.5 Nm M5	13.3 lb.in M5	13.3 lb.in M5	1.5 Nm M5	13.3 lb.in M5	13.3 lb.in M5

Type	P/N	Type	P/N

Characteristics	IEC	UL	CSA	IEC	UL	CSA

Busbar clamp

10 x 3 or 6 x 6 or 15 x 6 mm
 .34 x .12 or .23 x .23 or .59 x .23"
 DIN 1 - 2 - 3 or panel mount

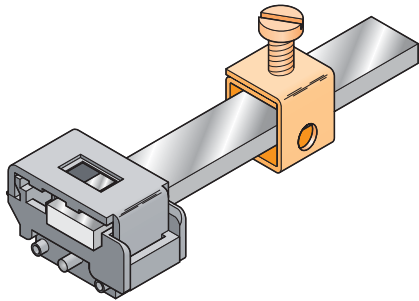

Rail		35 x 7,5 x 1	PR3.Z2	1SNA 174 300 R1700
Rail		35 x 15 x 2,3	PR4	1SNA 168 500 R1200
Rail		35 x 15 x 1,5	PR5	1SNA 168 700 R2200
Rail		32 x 15 x 1,5	PR1.Z2	1SNA 163 050 R0400

Other end stops, rails and accessories : see section on accessories.

Notes

Accessories

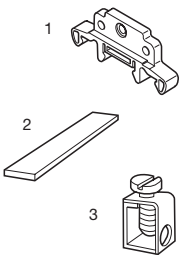

- 1 Locking foot
- 2 Busbar
- 3 Wire clamp



R See section on markers marking method

SPBO

Spacing 20 mm (.787")

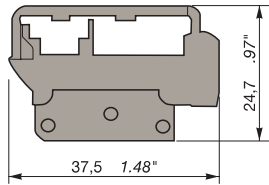

Colour	Type	Part number
Reversible grey clamp	SPBO	1SNA 114 712 R1300

Characteristics

Wire size	NFC	DIN	UL	CSA
Screw clamp	Rigid			
	Flexible			
Neutral bar	see beside			
Voltage				
Rated	~ AC	750 V Gr.C		
Rated	= DC	660 V Gr.C		
Pollution degree				
Current				
Rated				
Wire size				
Rated / Gauge				
Wire strip. length	Recomm. screwdriver	Recomm. torque	Protection	

Mounting on rail PR1 with mounting foot

ACD13-6 1SNA 113 135 R0000 (DIN 1 - DIN 3)

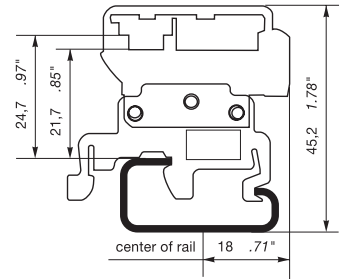

Mounting on rail PR2 with mounting foot

ACD23-6 1SNA 118 005 R2700 (DIN 2 - DIN 3)

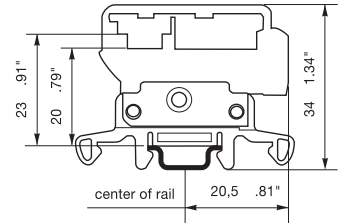

Mounting on rails PR3, PR30, PR4, PR5

with mount.foot **ACD13-6** 1SNA 113 135 R0000 (DIN 1 - DIN 3)

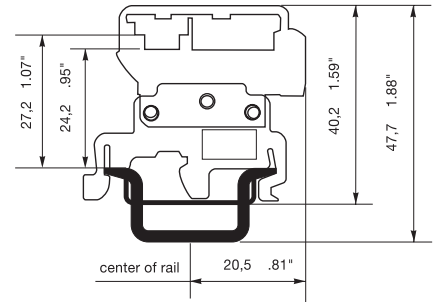

with mount.foot **ACD23-6** 1SNA 118 005 R2700 (DIN 2 - DIN 3)

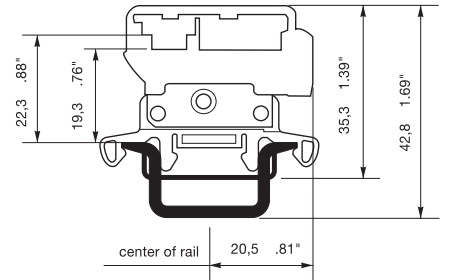

Mounting on panel by M4 screw

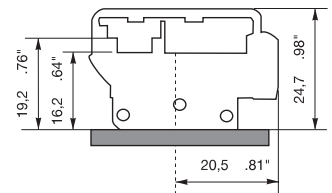

Various options of placing the busbars on the busbar clamp

Busbars	BO3 10 x 3	6 x 6	BO6 15 x 6
Option n° 1	X		
Option n° 2		X	
Option n° 3			X
Option n° 4	X		X
Option n° 5		X	X

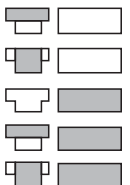

Distribution terminal blocks

- phase
- ground

DIN 1-3



End stop		th. 9 mm	BADL	V0	1SNA 399 903 R0200
End stop		th. 10 mm	BAM2	V2	1SNA 206 351 R1600
End stop		th. 10 mm	BAM2 V0	V0	1SNA 296 351 R0000
Rail		35 x 7,5 x 1	PR3.Z2		1SNA 174 300 R1700
Rail		35 x 15 x 2,3	PR4		1SNA 168 500 R1200
Rail		35 x 15 x 1,5	PR5		1SNA 168 700 R2200
Rail		32 x 15 x 1,5	PR1.Z2		1SNA 163 050 R0400

Other end stops, rails and accessories : see section on accessories.

Notes

The use of some accessories may decrease the block's voltage rating. For more information, consult us.

Example of application :

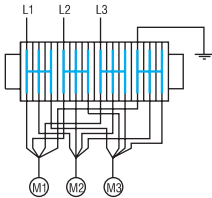

The monobloc connector bar ensures perfect continuity between input and distribution. Each block has 2 Screw clamp terminals.

Accessories

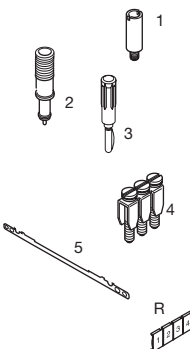

1	Test socket		
2	Test device		
3	Test plug		
4	Assembled jumper bar (without IP 20 protection)		
4	Assembled jumper bar (with IP 20 protection)		
5	Shield connector		
R	See section on markers marking method		

MB 4/6.L...

MB 4/6.P...

Spacing 6 mm (.238")

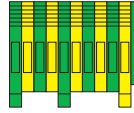
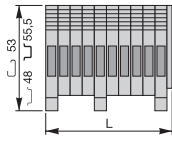

NFC : 30 A max., 60 A max., 30 A max./pole
 CSA : 25 A max., 50 A max., 25 A max./pole
 UL : 20 A max., 40 A max., 20 A max./pole

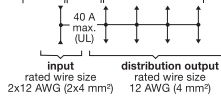

MB 6/8.L...

MB 6/8.P...

Spacing 8 mm (.315")

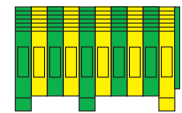
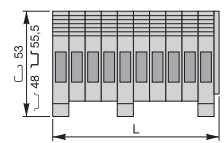

NFC : 51 A max., 102 A max., 51 A max./pole
 CSA : 35 A max., 70 A max., 35 A max./pole
 UL : 50 A max., 100 A max., 50 A max./pole

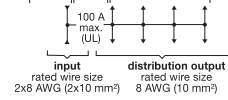

Colour	Type	Part numbers
	Nb of blocks	L mm
Phases		
Grey	2	14,5
Grey	3	20,5
Grey	4	26,5
Grey	5	32,5
Grey	6	38,5
Grey	8	50,5
Grey	10	62,5
Ground (no electrical connection to rail)		
Green-Yellow	2	14,5
Green-Yellow	3	20,5
Green-Yellow	4	26,5
Green-Yellow	5	32,5
Green-Yellow	6	38,5
Green-Yellow	8	50,5
Green-Yellow	10	62,5

Colour	Type	Part numbers
	Nb of blocks	L mm
Phases		
Grey	2	18,5
Grey	3	26,5
Grey	4	34,5
Grey	5	42,5
Grey	6	50,5
Grey	8	66,5
Grey	10	82,5
Ground (no electrical connection to rail)		
Green-Yellow	2	18,5
Green-Yellow	3	26,5
Green-Yellow	4	34,5
Green-Yellow	5	42,5
Green-Yellow	6	50,5
Green-Yellow	8	66,5
Green-Yellow	10	82,5

Characteristics

Wire size	IEC		UL	CSA
	NFC	DIN		
Screw clamp	Rigid	0,2-4 mm ²	22-10 AWG	22-12 AWG
	Flexible	0,22-4 mm ²	22-10 AWG	22-12 AWG

Characteristics

Wire size	IEC		UL	CSA
	NFC	DIN		
Screw clamp	Rigid	0,5-10 mm ²	22-8 AWG	20-8 AWG
	Flexible	0,5-6 mm ²	22-8 AWG	20-8 AWG

Voltage

Rated	800 V	600 V	600 V
Impulse withstand	8 kV		
Pollution degree	3		

Voltage

Rated	800 V	600 V	600 V
Impulse withstand	8 kV		
Pollution degree	3		

Current

Rated	Short-circuit	32A	300A/1s	20 A	25 A
-------	---------------	-----	---------	------	------

Current

Rated	Short-circuit	41A	720A/1s	50 A	35 A
-------	---------------	-----	---------	------	------

Wire size

Rated / Gauge	4 mm ² /A4	10 AWG	10 AWG
Wire strip. length	Recomm. screwdriver	Recomm. torque	Protection
9,5 mm	4 mm	0,5-0,8 Nm	IP20
.37"	.16"	4,5-7,1 lb.in	NEMA 1

Wire size

Rated / Gauge	6 mm ²	8 AWG	8 AWG
Wire strip. length	Recomm. screwdriver	Recomm. torque	Protection
12 mm	4-5 mm	0,8-1 Nm	IP20
.47"	.16-.20"	7,1-8,9 lb.in	NEMA 1

Type	Part numbers
AL2	DIA. 2 mm 1SNA 163 043 R2100
AL3	DIA. 3 mm 1SNA 163 261 R0000
DCJ	yellow 1SNA 173 059 R0300
FC2	DIA. 2 mm 1SNA 007 865 R2600
BJM6	2 to 10 poles (1)
BJMI6	2 to 10 poles (1)
CBM5	th. 0,5 mm 1SNA 178 745 R1400
CBM8	th. 0,8 mm 1SNA 178 746 R1500

Type	Part numbers
AL2	DIA. 2 mm 1SNA 163 043 R2100
AL3	DIA. 3 mm 1SNA 163 261 R0000
AL4	DIA. 4 mm 1SNA 163 262 R0100
DCO	orange 1SNA 173 060 R0000
FC2	DIA. 2 mm 1SNA 007 865 R2600
FC4	DIA. 4 mm 1SNA 167 860 R0100
BJM8	2 to 10 poles (1)
BJMI8	2 to 10 poles (1)

RC65 - RC610

Note : (1) See section : accessories

RC810

MB 10/10.L...

MB 10/10.P...

Spacing 10 mm (.394")

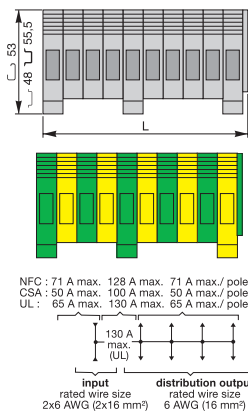

MB 70/10.L...

MB 70/10.P...

Spacing 10 mm (.394") with single connection point

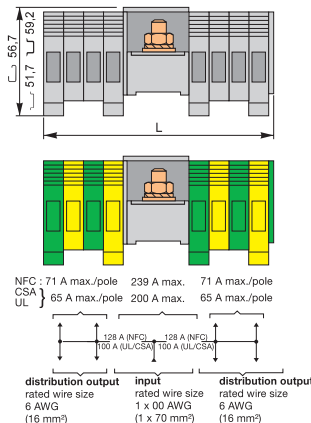

MB 2x70/10.L...

MB 2x70/10.P...

Spacing 10 mm (.394") with double connection point

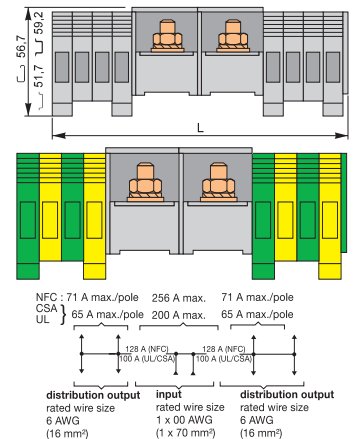

Colour	Type	Part numbers

Phases	Nb of blocks	L mm	Type	Part numbers
Grey	2	22,5	MB 10/10.L2	1SNA 115 328 R2300
Grey	3	32,5	MB 10/10.L3	1SNA 115 329 R2400
Grey	4	42,5	MB 10/10.L4	1SNA 115 330 R2100
Grey	5	52,5	MB 10/10.L5	1SNA 115 331 R1600
Grey	6	62,5	MB 10/10.L6	1SNA 115 332 R1700
Grey	8	82,5	MB 10/10.L8	1SNA 115 333 R1000
Grey	10	102,5	MB 10/10.L10	1SNA 115 334 R1100
Ground (no electrical connection to rail)				
Green-Yellow	2	22,5	MB 10/10.P2	1SNA 165 343 R0400
Green-Yellow	3	32,5	MB 10/10.P3	1SNA 165 344 R0500
Green-Yellow	4	42,5	MB 10/10.P4	1SNA 165 345 R0600
Green-Yellow	5	52,5	MB 10/10.P5	1SNA 165 346 R0700
Green-Yellow	6	62,5	MB 10/10.P6	1SNA 165 347 R0000
Green-Yellow	8	82,5	MB 10/10.P8	1SNA 165 348 R1100
Green-Yellow	10	102,5	MB 10/10.P10	1SNA 165 349 R1200

Colour	Type	Part numbers

Phases	Nb of blocks	L mm	Type	Part numbers
Grey	2x1	54	MB 70/10.L2	1SNA 115 335 R1200
Grey	2x2	74	MB 70/10.L4	1SNA 115 336 R1300
Grey	2x3	94	MB 70/10.L6	1SNA 115 337 R1400
Grey	2x4	114	MB 70/10.L8	1SNA 115 338 R2500
Ground (no electrical connection to rail)				
Green-Yellow	2x1	54	MB 70/10.P2	1SNA 165 350 R1700
Green-Yellow	2x2	74	MB 70/10.P4	1SNA 165 351 R0400
Green-Yellow	2x3	94	MB 70/10.P6	1SNA 165 352 R0500
Green-Yellow	2x4	114	MB 70/10.P8	1SNA 165 353 R0600

Colour	Type	Part numbers

Phases	Nb of blocks	L mm	Type	Part numbers
Grey	2x4	143	MB 2x70/10.L8	1SNA 115 342 R2100
Ground (no electrical connection to rail)				
Green-Yellow	2x4	143	MB 2x70/10.P8	1SNA 165 357 R0200

Characteristics

Wire size	IEC		UL	CSA
	Rigid	DIN		
Compression clamp	0,5-16 mm ²		22-6 AWG	18-6 AWG
Flexible	0,5-10 mm ²		22-6 AWG	18-6 AWG
Lugs	Max. 95 mm ²		00 AWG	00 AWG max.
	Rated 70 mm ²		00 AWG	00 AWG max.

Voltage			
Rated	800 V	600 V	600 V
Impulse withstand	8 kV		
Pollution degree	3		

Current			
Rated	Short-circuit	63A	1200A/1s
		65 A	50 A

Wire size			
Rated / Gauge	10 mm ²	6 AWG	6 AWG

Wire strip. length	Recomm. screwdriver	Recomm. torque	Protection
12 mm	5,5-6 mm	1,2-1,4 Nm	IP20
.47"	.22-.24"	10,6-12,3 lb.in	NEMA 1

Type	Part numbers
AL2	DIA. 2 mm 1SNA 163 043 R2100
AL3	DIA. 3 mm 1SNA 163 261 R0000
AL4	DIA. 4 mm 1SNA 163 262 R0100
FC2	DIA. 2 mm 1SNA 007 865 R2600
FC4	DIA. 4 mm 1SNA 167 860 R0100
BJM10	2 to 10 poles (1)
BJMI10	2 to 10 poles (1)

RC65 - RC610 RC810 RC1010
Note : (1) See section : accessories

Characteristics

Wire size	IEC		UL	CSA
	Rigid	DIN		
Compression clamp	0,5-16 mm ²		22-6 AWG	14-6 AWG
Flexible	0,5-10 mm ²		22-6 AWG	14-6 AWG
Lugs	Max. 95 mm ²		00 AWG	00 AWG max.
	Rated 70 mm ²		00 AWG	00 AWG max.

Voltage			
Rated	800 V	600 V	600 V
Impulse withstand	8 kV		
Pollution degree	3		

Current			
Rated	Short-circuit	63A	1200A/1s
		200 A	200 A

Wire size			
Rated / Gauge	10 mm ²	6 AWG	6 AWG

Wire strip. length	Recomm. screwdriver	Recomm. torque (screws)	Recomm. torque (lugs)
12 mm	5,5-6 mm	1,2-1,4 Nm	6 Nm
.47"	.22-.24"	10,6-12,3 lb.in	52 lb.in

Type	Part numbers
AL2	DIA. 2 mm 1SNA 163 043 R2100
AL3	DIA. 3 mm 1SNA 163 261 R0000
AL4	DIA. 4 mm 1SNA 163 262 R0100
FC2	DIA. 2 mm 1SNA 007 865 R2600
FC4	DIA. 4 mm 1SNA 167 860 R0100
BJM10	2 to 4 poles (1)
BJMI10	2 to 4 poles (1)

RC65 - RC610 RC810 RC1010

Characteristics

Wire size	IEC		UL	CSA
	Rigid	DIN		
Compression clamp	0,5-16 mm ²		22-6 AWG	14-6 AWG
Flexible	0,5-10 mm ²		22-6 AWG	14-6 AWG
Lugs	Max. 2x95 mm ²		00 AWG	00 AWG max.
	Rated 2x70 mm ²		00 AWG	00 AWG max.

Voltage			
Rated	800 V	600 V	600 V
Impulse withstand	8 kV		
Pollution degree	3		

Current			
Rated	Short-circuit	63A	1200A/1s
		200 A	200 A

Wire size			
Rated / Gauge	10 mm ²	6 AWG	6 AWG

Wire strip. length	Recomm. screwdriver	Recomm. torque (screws)	Recomm. torque (lugs)
12 mm	5,5-6 mm	1,2-1,4 Nm	6 Nm
.47"	.22-.24"	10,6-12,3 lb.in	52 lb.in

Type	Part numbers
AL2	DIA. 2 mm 1SNA 163 043 R2100
AL3	DIA. 3 mm 1SNA 163 261 R0000
AL4	DIA. 4 mm 1SNA 163 262 R0100
FC2	DIA. 2 mm 1SNA 007 865 R2600
FC4	DIA. 4 mm 1SNA 167 860 R0100
BJM10	2 to 4 poles (1)
BJMI10	2 to 4 poles (1)

RC65 - RC610 RC810 RC1010

Single pole distribution blocks

DIN 3

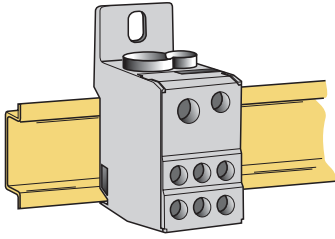

BADL		th. 9 mm	V0	1SNA 399 903 R0200
BAM2		th. 10 mm	V2	1SNA 206 351 R1600
BAM2 V0		th. 10 mm	V0	1SNA 296 351 R0000
BADH		th. 12 mm	V2	1SNA 116 900 R2700
BAMH		th. 9,1 mm	V2	1SNA 114 836 R0000
BAMH V0		th. 9,1 mm	V0	1SNA 194 836 R0100
PR3.Z2		35 x 7,5 x 1		1SNA 174 300 R1700
PR4		35 x 15 x 2,3		1SNA 168 500 R1200
PR5		35 x 15 x 1,5		1SNA 168 700 R2200

Other end stops, rails and accessories : see section on accessories.

BRU 80 A

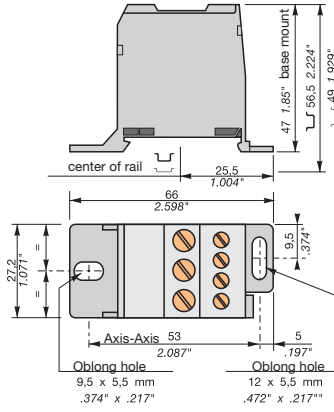

BRU 125 A

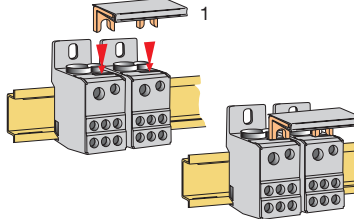
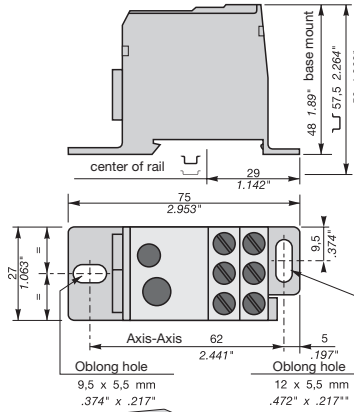

Rail (DIN 3) or base mounted (M5 screw)
Colour : grey

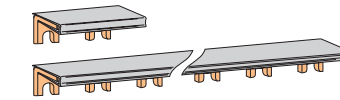

Jumper bar : 2 spades 20 mm² or 8 spades 20 mm² (to be cut)

BRU 160 A

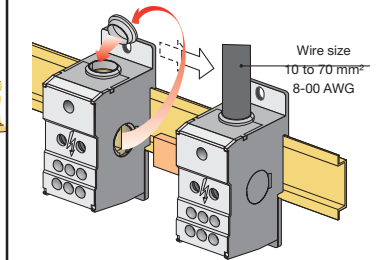
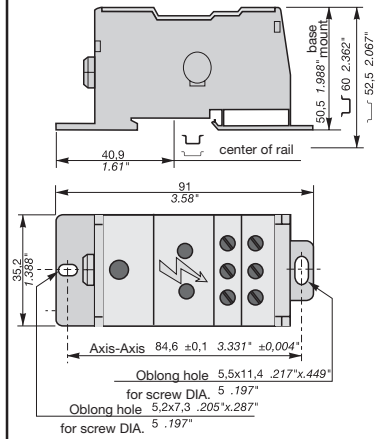

Rail (DIN 3) or base mounted (M5 screw)
Colour : grey

Wire size
10 to 70 mm²
8-00 AWG

Three holes on unit top allow wire entry from top or bottom.
Rail (DIN 3) or base mount with 2 x M5 screws. Unit may be mounted horizontally or vertically.
Finger contact protection IP 20.

UL		CE		UL		CE	
Type	P/N	Type	P/N	Type	P/N	Type	P/N
Grey body		Grey body		Grey body		Grey body	
BRU 80 A	1SNA 356 208 R2500	BRU 125 A	1SNA 356 204 R1100	BRU 160 A	1SNA 356 200 R2100		

Characteristics	IEC		UL/CSA		IEC		UL/CSA	
	Rated voltage	Rated current	Rated voltage	Rated current	Rated voltage	Rated current	Rated voltage	Rated current
Inputs (maximum wire size left input wire size right input wire size)	690 V	80 A	600 V	80 A	690 V	125 A	600 V	125 A
Recommended torque	2,5 - 16 mm ²	14 - 4 AWG	10 - 35 mm ²	6 - 16 mm ²	8 - 2 AWG	10 - 6 AWG	10 - 70 mm ²	8 - 00 AWG
Recommended torque wrench	1.5 Nm	1.5 Nm	3,5 Nm	Allen key/4 mm	31 lb.in	Allen key/4 mm	4 Nm	35 lb.in
Outputs with ferrules without ferrules	6 flats/5 mm	6 flats/5 mm	6 x 2,5 to 16 mm ²	6 x 2,5 to 16 mm ²	14 AWG to 6 AWG	14 AWG to 6 AWG	6 flats/5 mm	6 flats/5 mm
Recommended torque	2 Nm	2 Nm	2 Nm	0.8 Nm	17.6 lb.in	17.6 lb.in	2 Nm	17.6 lb.in
Recommended torque wire size with/without ferrule	2 x 16 mm ²	14 AWG to 4 AWG	2 x 16 mm ²	4 x 2.5 to 6 mm ²	14 AWG to 4 AWG	14 AWG to 6 AWG	6 x 2,5 to 16 mm ²	14 AWG to 6 AWG
Recommended torque wire size with or without ferrule	1,5 Nm	1,5 Nm	1,5 Nm	0.8 Nm	1,5 Nm	1,5 Nm	0.8 Nm	0.8 Nm
Recommended torque	4 x 2.5 to 6 mm ²	14 AWG to 10 AWG	4 x 2.5 to 6 mm ²	0.8 Nm	0.8 Nm	0.8 Nm	0.8 Nm	0.8 Nm
Screwdriver	Posidriv Z2 or flat		Posidriv Z2 or flat		Posidriv Z2 or flat		Posidriv Z2 or flat	
Weight	73 gr 0.16 lb		137 gr 0.3 lb		234 gr 0.516 lb		234 gr 0.516 lb	

Accessories	Type	P/N	Type	P/N	Type	P/N
1 Jumper bar	Coupling with wire (6 - 16 mm ²)		PCF.1.2 2 spades	1SNA 356 205 R1200		
2 Busbar 16 x 5 mm 160 A			PCF.1.8 8 spades	1SNA 356 206 R1300	BO 16/5 2 poles	1SNA 356 201 R1600
					BO 16/5 3 poles	1SNA 356 202 R1700
					BO 16/5 4 poles	1SNA 356 203 R1000

Four pole distribution blocks

DIN 3

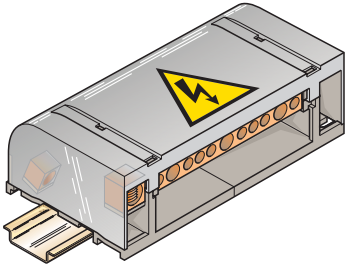

BADL		th. 9 mm	V0	1SNA 399 903	R0200
BAM2		th. 10 mm	V2	1SNA 206 351	R1600
BAM2 V0		th. 10 mm	V0	1SNA 296 351	R0000
BADH		th. 12 mm	V2	1SNA 116 900	R2700
BAMH		th. 9,1 mm	V2	1SNA 114 836	R0000
BAMH V0		th. 9,1 mm	V0	1SNA 194 836	R0100
PR3.Z2		35 x 7,5 x 1		1SNA 174 300	R1700
PR4		35 x 15 x 2,3		1SNA 168 500	R1200
PR5		35 x 15 x 1,5		1SNA 168 700	R2200

Other end stops, rails and accessories : see section on accessories.

Characteristics

Rated voltage	600 V
Rated current	80 A
Short circuit current	21,6 kA / 3 kA 1s.
Input	16 mm ²
Outputs (with ferrule)	8 x 10 mm ²

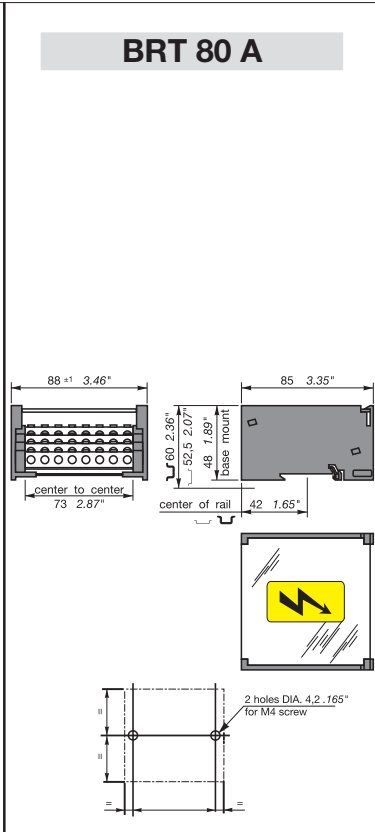

Rail or base mounted
Colour : grey

Type	P/N	Type	P/N
Grey body		Grey body	
BRT 80 A	1SNA 179 534 R2200	BRT 125 A	1SNA 179 535 R2300

IEC	UL	CSA
600 V	600 V	600 V
80 A	65 A	125 A
21,6 kA / 3 kA 1s.	21,6 kA	29,6 kA / 4,2 kA 1s.
16 mm ²	6 AWG	35 mm ²
8 x 10 mm ²	8 x 8 AWG	4 x 16 mm ²
		4 x 6 AWG
		7 x 10 mm ²
		7 x 8 AWG
Weight		
	210 gr	300 gr
	0,463 lb	0,661 lb

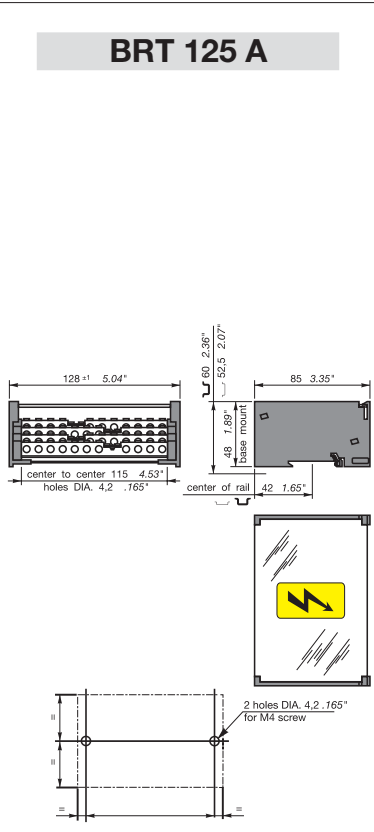

Rail or base mounted
Colour : grey

Type	P/N	Type	P/N
Grey body		Grey body	
BRT 125 A	1SNA 179 535 R2300	BRT 160 A	1SNA 179 892 R2200

IEC	UL	CSA
600 V	600 V	600 V
125 A	65 A	160 A
29,6 kA / 4,2 kA 1s.	29,6 kA	20 kA / 6,2 kA 1s.
35 mm ²	4 - 2 AWG	10 to 50 mm ²
4 x 16 mm ²	4 x 6 AWG	3 x 6 to 35 mm ²
		8 x 2,5 to 16 mm ²
Weight		
	300 gr	380 gr
	0,661 lb	0,837 lb

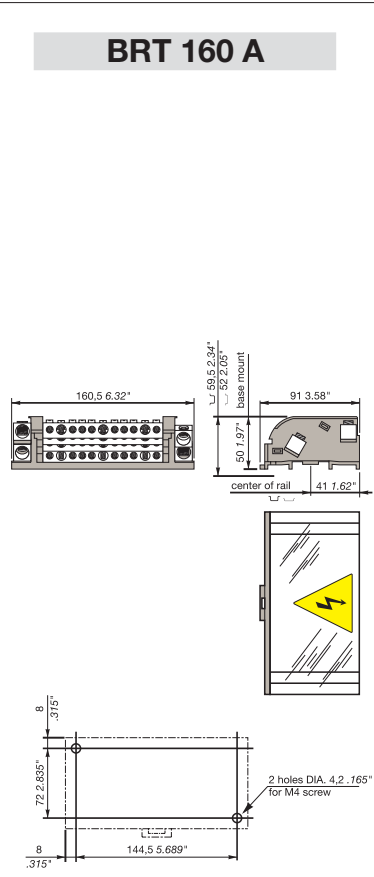

Rail or base mounted
Colour : grey

Type	P/N	Type	P/N
Grey body		Grey body	
BRT 160 A	1SNA 179 892 R2200		

IEC	UL	CSA
600 V	600 V	600 V
160 A	65 A	160 A
20 kA / 6,2 kA 1s.	29,6 kA	20 kA / 6,2 kA 1s.
10 to 50 mm ²	4 - 2 AWG	10 to 50 mm ²
3 x 6 to 35 mm ²	4 x 6 AWG	3 x 6 to 35 mm ²
8 x 2,5 to 16 mm ²	7 x 8 AWG	8 x 2,5 to 16 mm ²
Weight		
	300 gr	380 gr
	0,661 lb	0,837 lb



Helsinki
tel. +358 9 540 4940
automation@klinkmann.fi

Yekaterinburg
tel. +7 343 287 19 19
yekaterinburg@klinkmann.spb.ru

Vilnius
tel. +370 5 215 1646
post@klinkmann.lt

St. Petersburg
tel. +7 812 327 3752
klinkmann@klinkmann.spb.ru

Samara
tel. +7 846 273 95 85
samara@klinkmann.spb.ru

Tallinn
tel. +372 668 4500
klinkmann.est@klinkmann.ee

Moscow
tel. +7 495 641 1616
moscow@klinkmann.spb.ru

Kiev
tel. +38 044 495 33 40
klinkmann@klinkmann.kiev.ua

Minsk
tel. +375 17 200 0876
minsk@klinkmann.com

Riga
tel. +371 6738 1617
klinkmann@klinkmann.lv