

Logic relays

Product group picture

6



Logic relays

Table of contents

Logic relays

System overview	6/3
Approvals and marks	6/5
Ordering details - Stand alone logic relays	6/6
Ordering details - Expandable logic relays	6/7
Ordering details	6/8
Ordering details - Display systems	6/9
Technical data	6/10
TDimensional drawings	6/24

Logic relays

System overview

Concept

CL range logic relays are suitable for small and medium-sized control tasks and are able to substitute logic wiring in a quick and simple manner.

They can be used for applications in control as well as for timing functions, e.g.

- in buildings, lighting systems, air-conditioning systems, general control functions,
- in small machines and systems or
- as stand-alone control module for small applications.

Steps to the application of CL range

- CL range can be used easily, rapidly and comfortably without any time-consuming planning and programming.
- The user can discover the advantages and the benefit of these logic relays in no time at all.
- CL range provides for the control statements according to a simple circuit diagram.
- Setup, storage, simulation and documentation are performed using the compact and user-friendly CL-SOFT software (CL-LAS.PS002).

6

Software characteristics (CL-SOFT)

- Display on a PC monitor according to IEC, ANSI
- Different languages to choose from
- Easy installation on all Microsoft Windows™ operating systems

Technical data overview

Logic relays

- 8 or 12 digital inputs
- 4 or 6 digital relay outputs
- optionally with 4 or 8 transistor outputs
- 128 rungs
- 3 contacts as n/o or n/c contacts in series plus 1 coil per rung
- optionally with 2 or 4 analog inputs (not 100-240 V AC version)
- power flow display for checking the circuit diagram (devices with display)
- expansions for local or remote level
- enclosure color RAL 7035
- DIN rail mounting

Remote display

- Remote display up to a distance of 5 m
- Illustration of text and status displays
- Remote adjustment via keypad
- Front panel mounting

Logic links instead of wiring

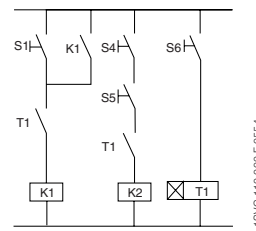

Documentation (download from the internet)

Logic relay manual: 1SVC440795M0100

Remote display manual: 1SVC440795M2100

Display system manual: 1SVC440795M1100

Display system

- useable as compact HMI logic relay
- fully graphic, backlit display module
- 12 digital inputs
- 4 digital relay outputs
- optionally with 4 transistor outputs
- 256 rungs
- 4 contacts as n/o or n/c contacts in series plus 1 coil per rung
- optionally with 4 analog inputs (not 100-240 V AC version)
- networking-compatible via CL-NET
- front panel mounting
- expansion for local

Software

- 16 timing relays 0.01-99:59 h
- 16 counting relays for up-, down counting
- 8 weekly timer, 8 annual timers
- 16 analog value comparators
- 16 freely editable display texts
- 32 markers or auxiliary relays

Logic relays

System overview

Logic relays

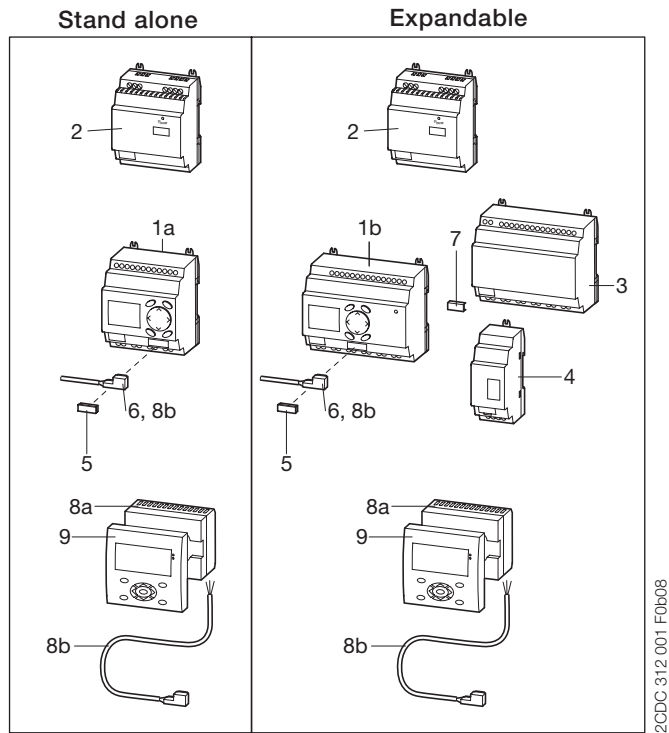

- 1a Logic relay CL-LS..
- 1b Expandable logic relay CL-LM..
- 2 Power supply CP-D...
- 3 I/O expansion CL-LER..., CL-LET.. for logic relays CL-LM..
- 4 Coupler unit CL-LEC.. for remote expansion of logic relays CL-LM..
- 5 Memory module CL-LAS.MD003 for logic relays CL-LS..., CL-LM..
- 6 Connecting cable CL-LAS.TK001, CL-LAS.TK002 to connect PC CL-LINK plug CL-LAS.TK011
- 7 to connect expansion to logic relays CL-LM..
- 8a Remote display connection module CL-LDC.S..
- 8b Connecting cable CL-LAD.TK007 to connect a remote displays to a logic relay
- 9 Display module CL-LDD..

Expansion of logic relays*

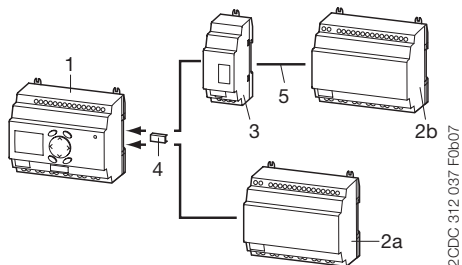

- 1 Logic relay CL-LM..
- 2 I/O expansion CL-LER..., CL-LET..
- 2a local expansion
- 2b remote expansion
- 3 Coupler unit CL-LEC.. for remote expansion of logic relays CL-LM..
- 4 CL-LINK plug CL-LAS.TK011 for expansion of logic relays CL-LM.. up to 30 m
- 5

* max. 1 expansion per logic relay

Display system → Compact HMI logic relay

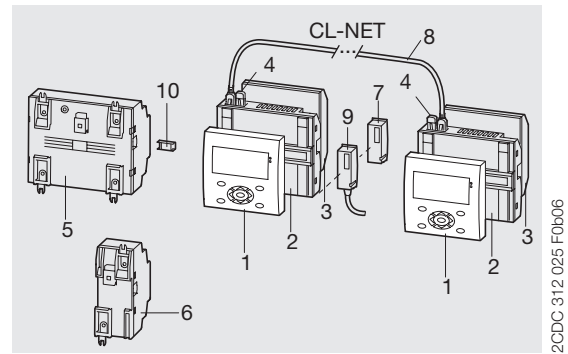

- 1 Display module CL-LDD..
- 2 Display base module CL-LDC.LN..
- 3 Display I/O module CL-LDR..., CL-LDT..
- 4 Termination resistor CL-LAD.TK009
- 5 I/O expansion CL-LER..., CL-LET..
- 6 Coupler unit CL-LEC.. for remote expansion
- 7 Memory module CL-LAD.MD004 for display base module
- 8 Connecting cable CL-LAD.TK002, CL-LAD.TK003, CL-LAD.TK004
- 9 Connecting cable CL-LAD.TK001, CL-LAD.TK011 to connect PC
- 10 CL-LINK plug CL-LAS.TK011 for expansion of logic relays CL-LM.. e.g. door of switchgear cabinet

Stand alone with I/O module

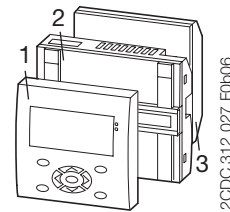

- 1 Display CL-LDD..
- 2 Remote display connection module CL-LDC.S.. incl. connecting cable
- 3 Display base module CL-LDC.L..

Communication via CL-NET

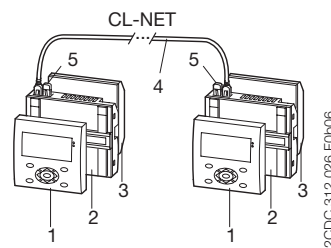









- 1 Display CL-LDD..
- 2 Display base module CL-LDC.LN.. for CL-NET
- 3 Display I/O module CL-LDR..., CL-LDT..
- 4 Connecting cable CL-LAD.TK002, CL-LAD.TK003, CL-LAD.TK004
- 5 Termination resistor CL-LAD.TK009

Logic relays

Approvals and marks

■ existing
□ pending

		Logic relays				Expansions			Display system				Accessories	
		CL-LSR	CL-LST	CL-LMR	CL-LMT	CL-LER	CL-LET	CL-LEC	CL-LDD	CL-LDC	CL-LDR	CL-LDT	CL-LAS	CL-LAD
Approvals														
	UL	■	■	■	■	■	■	■	■	■	■	■	■ ¹⁾	■ ²⁾
	CAN/CSA C22.2 No.14	■	■	■	■	■	■	■	■	■	■	■	■ ¹⁾	■ ²⁾
	CAN/CSA C22.2 No.213 (hazardous locations)	■	■	■	■	■	■	■	■	■	■	■	■ ¹⁾	■ ²⁾
	GL	■	■	■	■				■	■ ³⁾	■ ⁴⁾	■		
	EAC	□	□	□	□	□	□	□	□	□	□	□	□	□
	Lloyds Register	■	■	■	■				■	■ ³⁾	■ ⁴⁾	■		
Marks														
	CE	■	■	■	■	■	■	■	■	■	■	■	■	■
	C-Tick	□	□	□	□	□	□	□	□	□	□	□	□	□

¹⁾ not for: CL-LAS-PS002, CL-LAS.TD001, CL-LAS.FD001, CL-LAS.TK002, CL-LAS.TK011

²⁾ not for: CL-LAD.TK006, CL-LAD.TK011, CL-LAD.FD002

³⁾ not for: CL-LDC.SDC2, CL-LDC.SAC2, CL-LDC.LAC2, CL-LDC.LNAC2

⁴⁾ not for: CL-LDR.16AC2

Logic relays

Ordering details - Stand alone logic relays



CL-LSR

2CDC 281 034 F0006



CL-LST

2CDC 281 033 F0006

Ordering details - Logic relays stand alone

Rated operational voltage	Display + Keypad	Timer	Input / Output	Type	Order code	Price 1 pce	Weight (1 pce) kg (lb)
24 V AC	■	■	8 inputs / 4 relay outputs	CL-LSR.C12AC1	1SVR440712R0300		0.20 (0.44)
				CL-LSR.CX12AC1	1SVR440712R0200		
100-240 V AC	■	■		CL-LSR.12AC2	1SVR440713R0100		
				CL-LSR.C12AC2	1SVR440713R0300		
12 V DC	■	■		CL-LSR.CX12AC2	1SVR440713R0200		
				CL-LSR.C12DC1	1SVR440710R0300		
24 V DC	■	■		CL-LSR.CX12DC1	1SVR440710R0200		
				CL-LSR.12DC2	1SVR440711R0100		
24 V DC	■	■		CL-LSR.C12DC2	1SVR440711R0300		
				CL-LSR.CX12DC2	1SVR440711R0200		
24 V DC	■	■	8 inputs / 4 transistor outputs	CL-LST.C12DC2	1SVR440711R1300		
				CL-LST.CX12DC2	1SVR440711R1200		



CL-LDD.K

2CDC 281 028 F0006

Ordering details - Display modules

Rated operational voltage	Description	Type	Order code	Price 1 pce	Weight (1 pce) kg (lb)
-	Graphic display 132 x 64 pixel	CL-LDD.XK	1SVR440839R4500		0.14 (0.30)
-	Graphic display 132 x 64 pixel, with keypad	CL-LDD.K	1SVR440839R4400		0.13 (0.29)
24 V DC	Module to displace the display from the logic relay, incl. connecting cable CL-LAD.TK007, 5m, lenght adaptable	CL-LDC.SDC2	1SVR440841R0000		0.16 (0.36)
100-240 V AC		CL-LDC.SAC2	1SVR440843R0000		0.16 (0.36)



CL-LDC.S..

2CDC 281 017 F0007

Logic relays

Ordering details - Expandable logic relays



CL-LMR

2CDC 311 038 F0006

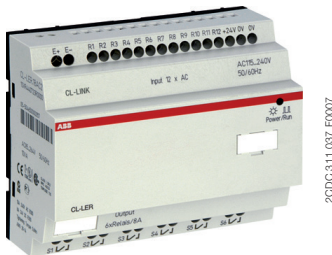

CL-LER

2CDC 311 037 F0007



CL-LEC

2CDC 311 038 F0006

Ordering details - Logic relays expandable

Rated operational voltage	Display + Keypad	Timer	Input / Output	Type	Order code	Price 1 pce	Weight (1 pce) kg (lb)
24 V AC	■	■	12 inputs / 6 relay outputs	CL-LMR.C18AC1	1SVR440722R0300		0.36 (0.79)
100-240 V AC	■	■		CL-LMR.CX18AC1	1SVR440722R0200		
				CL-LMR.C18AC2	1SVR440723R0300		
12 V DC	■	■		CL-LMR.CX18AC2	1SVR440723R0200		
				CL-LMR.C18DC1	1SVR440720R0300		
24 V DC	■	■		CL-LMR.CX18DC1	1SVR440720R0200		
			CL-LMR.C18DC2	1SVR440721R0300			
24 V DC	■	■	12 inputs, 8 transistor outputs	CL-LMT.C20DC2	1SVR440721R1300		0.36 (0.79)
				CL-LMT.CX20DC2	1SVR440721R1200		

Ordering details - Expansions

Rated operational voltage	Description	Type	Order code	Price 1 pce	Weight (1 pce) kg (lb)
-	2 relay outputs	CL-LER.20	1SVR440709R5000		0.07 (0.15)
100-240 V AC	12 inputs, 6 relay outputs	CL-LER.18AC2	1SVR440723R0000		0.26 (0.57)
24 V DC		CL-LER.18DC2	1SVR440721R0000		0.22 (0.49)
24 V DC	12 inputs, 8 transistor outputs	CL-LET.20DC2	1SVR440721R1000		0.21 (0.46)
-	Coupler unit for remote expansion with a distance of up to 30 m	CL-LEC.CI000	1SVR440709R0000		0.07 (0.15)

Logic relays

Ordering details



CL-LAS.PS002



CL-LAS.TK001



CL-LAS.MD003

2CDC 311 012 F0007

2CDC 311 014 F0007

2CDC 311 013 F0007

Ordering details - CL-LA...

Description	Type	Order code	Price 1 pce	Weight (1 pce) kg (lb)
Software for programming and control of CL range devices. Installation CD-ROM for Microsoft Windows™.	CL-LAS.PS002	1SVR440799R8000		0.10 (0.21)
Memory module for logic relays Memory size: 32 kB	CL-LAS.MD003	1SVR440799R7000		0.02 (0.04)
Cable with serial interface to connect PC and logic relay. Length: 2 m	CL-LAS.TK001	1SVR440799R6000		0.10 (0.22)
Cable with USB interface to connect PC and logic relay. Length: 2 m	CL-LAS.TK002	1SVR440799R6100		0.06 (0.13)
Cable for point-to-point connection of remote-display connection module and logic relay, length: 5m, adaptable	CL-LAD.TK007	1SVR440899R6600		0.20 (0.44)
Fixing brackets for screw mounting of logic relay, expansion, display base module	CL-LAS.FD001	1SVR440799R5000		0.01 (0.01)
Spare plug (CL-LINK) for connection of logic relay to expansion	CL-LAS.TK011	1SVR440799R5100		0.10 (0.22)
Primary switch mode power supplies, Rated input voltage: 100-240 V AC Rated output voltage/current: 24 V DC / 0.42 A	CP-D 24/0.421)	1SVR427041R0000		0.06 (0.13)
Primary switch mode power supplies, Rated input voltage: 100-240 V AC Rated output voltage/current: 24 V DC / 1.3 A	CP-D 24/1.32)	1SVR427043R0100		0.19 (0.41)

¹⁾ replaces CL-LAS.SD001, technical data see chapter "Primary switch mode power supplies"

²⁾ replaces CL-LAS.SD002, technical data see chapter "Primary switch mode power supplies"

Logic relays

Ordering details - Display systems



CL-LDD.K

2CDC 311 028 F0006

Ordering details - Display systems

Rated operational voltage	Description	Type	Order code	Price 1 pce	Weight (1 pce) kg (lb)
-	Display module Graphic display 132 x 64 pixel	CL-LDD.XK	1SVR440839R4500		0.14 (0.30)
-	Display module Graphic display 132 x 64 pixel, with keypad	CL-LDD.K	1SVR440839R4400		0.13 (0.29)
24 V DC	Display base module CPU / power supply	CL-LDC.LDC2	1SVR440821R0000		0.16 (0.36)
100-240 V AC		CL-LDC.LAC2	1SVR440823R0000		
24 V DC	Display base module CPU / power supply, network- ing-compatible (CL-NET)	CL-LDC.LNDC2	1SVR440821R1000		0.17 (0.38)
100-240 V AC		CL-LDC.LNAC2	1SVR440823R1000		
100-240 V AC	Display I/O module 12 inputs, 4 relay outputs	CL-LDR.16AC2	1SVR440853R0000		0.17 (0.38)
24 V DC		CL-LDR.16DC2	1SVR440851R0000		
24 V DC	Display I/O module 12 inputs, 4 relay outputs, 1 analog output	CL-LDR.17DC2	1SVR440851R2000		0.17 (0.38)
24 V DC	Display I/O module 12 inputs, 4 transistor outputs	CL-LDT.16DC2	1SVR440851R1000		0.14 (0.30)
24 V DC	Display I/O module 12 inputs, 4 transistor outputs, 1 analog output	CL-LDT.17DC2	1SVR440851R3000		0.14 (0.30)



CL-LDC.LN..

2CDC 311 031 F0006

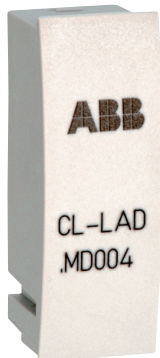

CL-LAD.MD004

2CDC 311 018 F0007

Ordering details - CL-LAD...

Description	Type	Order code	Price 1 pce	Weight (1 pce) kg (lb)
Memory module for display base modules Memory size: 256 kB	CL-LAD.MD004	1SVR440899R7000		0.02 (0.03)
Cable with serial interface to connect PC and display base module	CL-LAD.TK001	1SVR440899R6000		0.11 (0.23)
Cable with USB interface to connect PC and display base module	CL-LAD.TK011	1SVR440899R6700		
Network cable (CL-NET) to connect 2 display base modules Length: 0.3 m	CL-LAD.TK002	1SVR440899R6100		0.05 (0.12)
Network cable (CL-NET) to connect 2 display base modules Length: 0.8 m	CL-LAD.TK003	1SVR440899R6200		0.07 (0.14)
Network cable (CL-NET) to connect 2 display base modules Length: 1.5 m	CL-LAD.TK004	1SVR440899R6300		0.08 (0.18)
Cable for point-to-point connection of remote display connection modules and display base module, length adaptable, Length: 5 m	CL-LAD.TK005	1SVR440899R6400		0.20 (0.44)
Cable for point-to-point connection of 2 display base modules, length adaptable. Length: 5 m	CL-LAD.TK006	1SVR440899R6500		0.12 (0.26)
Termination resistor, content: 2 pieces	CL-LAD.TK009	1SVR440899R6900		0.01 (0.02)
Protective cover, transparent, for harsh envi- ronmental conditions and application in the food industry	CL-LAD.FD001	1SVR440899R1000		0.03 (0.07)
Protective cover, transparent and sealable	CL-LAD.FD011	1SVR440899R2000		0.03 (0.07)
Assembly tool for mounting of display mod- ules	CL-LAD.FD002	1SVR440899R3000		



CL-LAD.TK001

2CDC 311 019 F0007



CL-LAD.TK002

2CDC 311 020 F0006

Logic relays

Technical data

Data at $T_a = 25\text{ °C}$ and rated values, if nothing else indicated.

Type	CL-LSR.C...12DC1	CL-LSR...12DC2 CL-LST.C...12DC2	CL-LSR.C...12AC1	CL-LSR...12AC2
Input circuit - supply circuit				
Rated operational voltage U_o	12 V DC	24 V DC	24 V AC	100-240 V AC
Rated operational voltage tolerance	-15...+30 %	-15...+20 %	-15...+10 %	-
Operational voltage range	10.2-15.6 V DC	20.4-28.8 V DC	20.4-26.4 V AC	85-264 V AC
Rated frequency	0 Hz	-	50/60 Hz	-
Rated frequency tolerance	-	-	±5 %	-
Residual ripple	≤ 5 %	-	-	-
Input current	at 12 V DC typ. 140 mA	-	-	-
	at 24 V DC	typ. 80 mA	-	-
	at 24 V AC	-	typ. 200 mA	-
	at 115/120 V AC (60 Hz)	-	-	typ. 40 mA
	at 230/240 V AC (50 Hz)	-	-	typ. 20 mA
Power failure buffering (IEC/EN 61131-2)	10 ms	-	20 ms	-
Power dissipation	at 12 V DC typ. 2 W	-	-	-
	at 24 V DC	typ. 2 W	-	-
	at 24 V AC	-	typ. 5 VA	-
	at 115/120 V AC	-	-	typ. 5 VA
	at 230/240 V AC	-	-	typ. 5 VA
Type	CL-LMR.C...18DC1	CL-LMR.C...18DC2 CL-LMT.C...20DC2	CL-LMR.C...18AC1	CL-LMR.C...18AC2
Input circuit - supply circuit				
Rated operational voltage U_o	12 V DC	24 V DC	24 V AC	100-240 V AC
Rated operational voltage tolerance	-15...+30 %	-15...+20 %	-15...+10 %	-
Operational voltage range	10.2-15.6 V DC	20.4-28.8 V DC	20.4-26.4 V AC	85-264 V AC
Rated frequency	0 Hz	-	50/60 Hz	-
Rated frequency tolerance	-	-	±5 %	-
Residual ripple	≤ 5 %	-	-	-
Input current	at 12 V DC typ. 200 mA	-	-	-
	at 24 V DC	typ. 140 mA	-	-
	at 24 V AC	-	typ. 300 mA	-
	at 115/120 V AC (60 Hz)	-	-	typ. 70 mA
	at 230/240 V AC (50 Hz)	-	-	typ. 35 mA
Power failure buffering (IEC/EN 61131-2)	10 ms	-	20 ms	-
Power dissipation	at 12 V DC typ. 3.5 W	-	-	-
	at 24 V DC	typ. 3.5 W	-	-
	at 24 V AC	-	typ. 7 VA	-
	at 115/120 V AC	-	-	typ. 10 VA
	at 230/240 V AC	-	-	typ. 10 VA
Type	CL-LER.18DC2 CL-LET.20DC2	CL-LER.18AC2		
Input circuit - supply circuit				
Rated operational voltage U_o	24 V DC	100-240 V AC		
Rated operational voltage tolerance	-15...+20 %	-15...+10 %		
Operational voltage range	20.4-28.8 V DC	85-264 V AC		
Rated frequency	0 Hz	50/60 Hz		
Rated frequency tolerance	-	±5 %		
Residual ripple	≤ 5 %	-		
Input current	at 24 V DC typ. 140 mA	-		
	at 115/120 V AC (60 Hz)	typ. 70 mA		
	at 230/240 V AC (50 Hz)	typ. 35 mA		
Power failure buffering (IEC/EN 61131-2)	10 ms	20 ms		
Power dissipation	at 24 V DC typ. 3.4 W	-		
	at 115/120 V AC	typ. 10 VA		
	at 230/240 V AC	typ. 10 VA		

Logic relays

Technical data

Data at $T_a = 25\text{ °C}$ and rated values, if nothing else indicated.

Type		CL-LSR.C...12DC1	CL-LSR...12DC2 CL-LST.C...12DC2	CL-LSR.C...12AC1	CL-LSR.C...12AC2
Input circuit - Digital inputs					
Number		8			
Inputs can be used as analog inputs		2 (I7, I8)			
Indication of operational states		LCD-Display (if existing)			
Electrical isolation	from voltage supply	no			
	between digital inputs	no			
	from the outputs	yes			
Rated operational voltage U_o		12 V DC	24 V DC	24 V AC	
	U_o on „0“ signal	4 V DC (I1-I8)	< 5 V DC (I1-I8)	0-6 V AC (sinusoidal)	0-40 V AC (sinusoidal)
	U_o on „1“ signal	8 V DC (I1-I8)	> 15 V DC (I1-I6), > 8 V DC (I7, I8)	> 9.5 V DC, 14-26.4 V AC (sinusoidal) (I1-I6), > 7 V AC (sinusoidal) (I7, I8)	79-264 V AC (sinusoidal)
Rated frequency				50-60 Hz	
Input current on „1“ signal		3.3 mA (at 12 V DC, I1-I6), 1.1 mA (at 12 V DC, I7, I8)	3.3 mA (at 24 V DC, I6-I7), 2.2 mA (at 24 V DC, I7, I8)	4 mA (at 24 V AC, 50 Hz, I1-I6), 2 mA (at 24 V AC, 50 Hz, I7, I8), 2 mA (at 24 V DC, I7, I8)	6x0.25 mA (at 115 V AC, 60 Hz, I1-I6), 6x0.5 mA (at 230 V AC, 50 Hz, I1-I6) 2x4 mA (at 115 V AC, 60 Hz, I7, I8), 2x6 mA (at 230 V AC, 50 Hz, I7, I8)
Time delay from „0“ to „1“	debounce ON	20 ms		80 ms (at 50 Hz), 66 2/3 ms (at 60 Hz)	
	debounce OFF	typ. 0.3 ms (I1-I6), typ. 0.35 ms (I7, I8)	typ. 0.25 ms (I1-I8)	20 ms (at 50 Hz), 16 2/3 ms (at 60 Hz)	
Time delay from „1“ to „0“	debounce ON	20 ms		80 ms (at 50 Hz), 66 2/3 ms (at 60 Hz)	80 ms (at 50 Hz, I1-I6), 66 2/3 ms (at 60 Hz, I1-I6) 160 ms (at 50 Hz, I7, I8), 150 ms (at 60 Hz, I7, I8)
	debounce OFF	typ. 0.3 ms (I1-I6), typ. 0.15 ms (I7, I8)	-	20 ms (at 50 Hz), 16 2/3 ms (at 60 Hz)	20 ms (at 50 Hz, I1-I6), 16 2/3 ms (at 60 Hz, I1-I6) 100 ms (at 50 Hz, I7, I8), 100 ms (at 60 Hz, I7, I8)
Cable length (unshielded)		100 m			
Maximum cable length per input		-		40 m	40 m (I1-I6), 100 m (I7, I8)
Frequency counter	Number	2 (I3, I4)			
	counting frequency	< 1 kHz			
	pulse shape	square-wave			
	pulse / pause ratio	1:1			
Rapid counter inputs	Number	2 (I1, I2)			
	counting frequency	< 1 kHz			
	pulse shape	square-wave			
	pulse / pause ratio	1:1			
Cable length (shielded)		< 20 m			
Input circuit - Analog inputs					
Number		2 (I7, I8)			
Electrical isolation	from voltage supply	no			
	from the digital inputs	no			
	from the outputs	yes			
	from PC interface, memory module, CL-NET, CL-LINK	no			
Input type		DC voltage			
Signal range		0-10 V DC			
Resolution	analog	0.01 V			
	digital	0.01 V; 10 Bit (value 1-1023)			
Input impedance		11.2 k Ω			
Accuracy of the actual value	two CL devices	$\pm 3\%$			
	within one device	$\pm 2\%$, $\pm 0.12\text{ V}$			
Conversion time analog/digital	Input delay ON	20 ms			
	Input delay OFF	each cycle			
Input current		< 1 mA			
Cable length (shielded)		< 30 m			

Logic relays

Technical data

Data at $T_a = 25\text{ °C}$ and rated values, if nothing else indicated.

Type	CL-LMR.C...18DC1	CL-LMR.C...18DC2 CL-LMT.C...20DC2	CL-LMR.C...18AC1	CL-LMR.C...18AC2
Input circuit - Digital inputs	12 V DC	24 V DC	24 V AC	115 / 230 V AC
Number	12			
Inputs can be used as analog inputs	4 (I7, I8, I11, I12)			-
Indication of operational states	LCD-Display (if existing)			
Electrical isolation				
from voltage supply	no			
between digital inputs	no			
from the outputs	yes			
from PC interface, memory module, CL-NET, CL-LINK	no			yes
Rated operational voltage U_e				
U_e on „0“ signal	12 V DC 4 V DC (I1-I12)	24 V DC < 5 V DC (I1-I12, R1-R12)	24 V AC 0-6 V AC (sinusoidal)	0-40 V AC (sinusoidal)
U_e on „1“ signal	8 V DC (I1-I12)	> 15 V DC (I1-I6, I9, I10) > 8 V DC (I7, I8, I11, I12)	> 9.5 V DC, 14-26.4 V AC (sinusoidal) (I1-I6, I9, I10) > 7 V AC (sinusoidal) (I7, I8; I11, I12)	79-264 V AC (sinusoidal)
Rated frequency	-		50-60 Hz	
Input current on „1“ signal	3.3 mA (at 12 V DC, I1-I6, I9-I12), 1.1 mA (at 12 V DC, I7, I8)	3.3 mA (at 24 V DC, I1-I6, I9, I10), 2.2 mA (at 24 V DC, I7, I8, I11, I12)	4 mA (at 24 V AC, 50 Hz, I1-I6, I9, I10), 2 mA (at 24 V AC, 50 Hz, I7, I8, I11, I12), 2 mA (at 24 V DC, I7, I8, I11, I12)	6x0.25 mA (at 115 V AC, 60 Hz, I1-I6), 6x0.5 mA (at 230 V AC, 50 Hz, I1-I6) 2x4 mA (at 115 V AC, 60 Hz, I7, I8), 2x6 mA (at 230 V AC, 50 Hz, I7, I8), 4x0.25 mA (at 115 V AC, 60 Hz, I9-I12), 4x0.5 mA (at 230 V AC, 50 Hz, I9-I12)
Time delay from „0“ to „1“	debounce ON 20 ms debounce OFF typ. 0.3 ms (I1-I6, I9, I10), typ. 0.35 ms (I7, I8, I11, I12)	typ. 0.25 ms	80 ms (at 50 Hz), 66 2/3 ms (at 60 Hz) 20 ms (at 50 Hz), 16 2/3 ms (at 60 Hz)	
Time delay from „1“ to „0“	debounce ON 20 ms debounce OFF typ. 0.4 ms (I1-I6, I9, I10), typ. 0.35 ms (I7, I8, I11, I12)	-	80 ms (at 50 Hz), 66 2/3 ms (at 60 Hz) 20 ms (at 50 Hz), 16 2/3 ms (at 60 Hz)	
Cable length (unshielded)	100 m			
Maximum cable length per input			max. 40 m, typ. 40 m (I9, I10)	typ. 40 m (I1-I6, I9-I12), typ. 100 m (I7, I8)
Frequency counter				
number	2 (I3, I4)			
counting frequency	< 1 kHz			
pulse shape	square-wave			
pulse / pause ratio	1:1			
Rapid counter inputs				
number	2 (I1, I2)			
counting frequency	< 1 kHz			
pulse shape	square-wave			
pulse / pause ratio	1:1			
Cable length (shielded)	< 20 m			
Input circuit - Analog inputs				
Number	4 (I7, I8, I11, I12)			
Electrical isolation				
from voltage supply	no			
from the digital inputs	no			
from the outputs	yes			
from PC interface, memory module, CL-NET, CL-LINK	no			
Input type	DC voltage			
Signal range	0-10 V DC			
Resolution	analog 0.01 V digital 0.01 V; 10 Bit (value 1-1023)			
Input impedance	11.2 k Ω			
Accuracy of the actual value	two CL devices $\pm 3\%$ within one device $\pm 2\%$, $\pm 0.12\text{ V}$			
Conversion time	Input delay ON 20 ms			
analog/digital	Input delay OFF each cycle			
Input current	< 1 mA			
Cable length (shielded)	< 30 m			

Logic relays

Technical data

Data at $T_a = 25\text{ °C}$ and rated values, if nothing else indicated.

Type		CL-LER.18DC2, CL-LET.20DC2	CL-LER.18AC2
Input circuit - Digital inputs		24 V DC	115 / 230 V AC
Number		12	
Inputs can be used as analog inputs		-	
Indication of operational states		-	
Electrical isolation	from voltage supply	no	
	between digital inputs	no	
	from the outputs	yes	
	from PC interface, memory module, CL-NET, CL-LINK	no	
Rated operational voltage U_e		24 V DC	
	U_e on „0“ signal	< 5 V DC (I1-I12, R1-R12)	0-40 V AC (sinusoidal)
	U_e on „1“ signal	-	79-264 V AC (sinusoidal)
Rated frequency		-	50-60 Hz
Input current on „1“ signal		3.3 mA (at 24 V DC, R1-R12)	12x0.25 mA (at 115 V AC, 60 Hz, R1-R12), 12x0.5 mA (at 230 V AC, 50 Hz, R1-R12)
	Time delay from „0“ to „1“	debounce ON	20 ms
debounce OFF		typ. 0.25 ms (R1-R12)	20 ms (at 50 Hz, I1-I12, R1-R12), 16 2/3 ms (at 60 Hz, I1-I12, R1-R12)
Time delay from „1“ to „0“	debounce ON	20 ms	80 ms (at 50 Hz, I1-I12, R1-R12), 66 2/3 ms (at 60 Hz, I1-I12, R1-R12)
	debounce OFF	-	20 ms (at 50 Hz, I1-I12, R1-R12), 16 2/3 ms (at 60 Hz, I1-I12, R1-R12)
Cable length (unshielded)		100 m	-
Maximum cable length per input		-	typ. 40 m (I1-I6, I9-I12, R1-R12), typ. 100 m (I7, I8)

6

Logic relays

Technical data

Data at $T_a = 25\text{ °C}$ and rated values, if nothing else indicated.

Type	CL-LSR...	CL-LMR... CL-LER...	CL-LER.20
Output circuit - Relay outputs			
Number	4	6	2
Outputs in groups of	1		2
Parallel switching of outputs to increase capacity	not permissible		
Fusing of the output relay	circuit-breaker B16 or fuse 8 A (slow-acting)		
Electrical isolation	from voltage supply	yes	
	from the inputs	yes	
	from PC interface, memory module, CL-NET, CL-LINK	no	
	protective separation	300 V AC	
	basic isolation	600 V AC	
Mechanical lifetime	10x10 ⁶ switching cycles		
Rung	conventional thermal current (10 A UL)	8 A	
	recommended for load 12 V AC/DC	> 500 mA	
	short-circuit proof $\cos \varphi = 1$; characteristic B16 at 600 A	16 A	
	short-circuit proof $\cos \varphi = 0,5$ up to 0,7; characteristic B16 at 900 A	16 A	
	Rated impulse withstand voltage U_{imp} contact-coil	6 kV	
	Rated operational voltage U_o	250 V AC	
	Rated insulation voltage U_i	250 V AC	
Protective separation (EN 50178)	between coil and contact	300 V AC	
	between two contacts	300V AC	
Making capacity	AC-15, 250 V AC, 3 A (600 ops./h)	300.000 switching cycles	
	DC13, L/R \leq 150 ms, 24 V DC, 1 A (500 ops./h)	200.000 switching cycles	
Breaking capacity	AC-15, 250 V AC, 3 A (600 ops./h)	300.000 switching cycles	
	DC13, L/R \leq 150 ms, 24 V DC, 1 A (500 ops./h)	200.000 switching cycles	
Incandescent lamp load	1000 W at 230/240 V AC	25.000 switching cycles	
	500 W at 115/120 V AC	25.000 switching cycles	
Fluorescent lamp load	10 x 58 W at 230/240 V AC with electrical control gear	25.000 switching cycles	
	10 x 58 W at 230/240 V AC uncompensated	25.000 switching cycles	
	1 x 58 W at 230/240 V AC conventional compensated	25.000 switching cycles	
	1 x 58 W at 230/240 V AC mechanical operations	10x10 ⁶	
Switching frequency	switching frequency	10 Hz	
	resistive load / lamp load	2 Hz	
	inductive load	0.5 Hz	
UL/CSA			
Continuous current at 240 V	10 A AC		
Continuous current at 24 V	8 A DC		
AC	Utilization category (Control Circuit Rating Codes)	B 300 Light Pilot Duty	
	max. rated operational voltage	300 V AC	
	max. continuous thermal current $\cos \varphi = 1$ at B 300	5 A	
	max. making / breaking apparent power (Make/Break) $\cos \varphi \neq 1$ at B 300	3600/360 VA	
DC	Utilization category (Control Circuit Rating Codes)	R 300 Light Pilot Duty	
	max. rated operational voltage	300 V DC	
	max. continuous thermal current at R 300	1 A	
	max. making / breaking apparent power (Make/Break) at R 300	28/28 VA	

Logic relays

Technical data

Data at $T_a = 25\text{ °C}$ and rated values, if nothing else indicated.

Type	CL-LST...	CL-LMT...	CL-LET...
Output circuit - Transistor outputs			
Number	4	8	
Rated operational voltage U_o	24 V DC		
Operational voltage range	20.4-28.8 V DC		
Residual ripple	$\leq 5\%$		
Supply current	on „0“ signal typ. 9 mA / max. 16 mA	typ. 18 mA / max. 32 mA	
	on „1“ signal typ. 12 mA / max. 22 mA	typ. 24 mA / max. 44 mA	
Reverse voltage protection	yes (Attention: If supply voltage is reversed, applying voltage at the outputs, causes a short circuit.)		
Electrical isolation	from voltage supply	yes	
	from the inputs	yes	
	from PC interface, memory module, CL-NET, CL-LINK	-	
Rated operational current I_o on „1“ signal DC	max. 0.5 A		
Lamp load without R_v	5 W		
Residual current on „0“ signal per channel	$< 0.1\text{ mA}$		
Max. output voltage	on „0“ signal at external load $< 10\text{ M}\Omega$	2.5 V	
	on „1“ signal at $I_e = 0.5\text{ A}$	$U = U_e - 1\text{ V}$	
Short-circuit protection	yes, thermal (analysis results from diagnosis input I16, I15; R15, R16)		
Short-circuit tripping current for $R_a \leq 10\text{ m}\Omega$	$0.7\text{ A} \leq I_o \leq 2\text{ A}$ per output		
Total short-circuit current	8 A	16 A	
Peak short-circuit current	16 A	32 A	
Thermal tripping	yes		
Max. switching frequency with constant resistive load $R_L < 100\text{ k}\Omega$ (depending on active channels and their load)	40.000 switching cycles/h		
Parallel connection of outputs	with resistive load, inductive load with external suppressor, combination within one group	group 1: Q1-Q4, group 2: Q5-Q8	group 1: S1-S4, group 2: S5-S8
	number of outputs	max. 4	
	max. total current	2 A (Attention! Outputs must be actuated simultaneously and for the same length of time.)	
Indication of operational states of the outputs	LCD-Display (if existing)		
Inductive load ¹⁾ without external suppressor			
$T_{0.95} = 1\text{ ms}$, $R = 48\ \Omega$, $L = 16\text{ mH}$	utilization factor	0.25 g	
	duty time	100 %	
	max. switching frequency $f = 0.5\text{ Hz}$ (max. duty time = 50 %)	1500 switching cycles	
DC13, $T_{0.95} = 72\text{ ms}$, $R = 48\ \Omega$, $L = 1.15\text{ H}$	utilization factor	0.25 g	
	duty time	100 %	
	max. switching frequency $f = 0.5\text{ Hz}$ (max. duty time = 50 %)	1500 switching cycles	
$T_{0.95} = 15\text{ ms}$, $R = 48\ \Omega$, $L = 0.24\text{ H}$	utilization factor	0.25 g	
	duty time	100 %	
	max. switching frequency $f = 0.5\text{ Hz}$ (max. duty time = 50 %)	1500 switching cycles	
Inductive load ¹⁾ with external suppressor			
	demand factor	1 g	
	duty time	100 %	
	max. switching frequency	depends on suppressor	
	max. duty time		

1) For inductive loading, without external suppression of the transistor outputs, the following applies:

$T_{0.95}$ = time in ms, until 95 % of the steady-state current is achieved. $T_{0.95} \cdot 3 \times T_{0.65} = 3 \times L/R$.

Data transfer rate in the CL-NET network: bus lengths of 40 m and over only attainable with cables with additional cross-section and connection adapter.

Logic relays

Technical data

Data at $T_a = 25\text{ °C}$ and rated values, if nothing else indicated.

Type	CL-LSR..., CL-LST...	CL-LMR... CL-LMT... CL-LET..., CL-LER.18..	CL-LER.20 CL-LEC.CI000
General data			
Dimensions (W x H x D)	71.5 mm x 90 mm x 58 mm (2.81 inch x 3.54 inch x 2.28 inch)	107.5 mm x 90 mm x 58 mm (4.23 inch x 3.54 inch x 2.28 inch)	35.5 mm x 90 mm x 58 mm (1.40 inch x 3.54 inch x 2.28 inch)
Weight	0.2 kg (0.44 lb)	0.3 kg (0.66 lb)	0.07 kg (0.15 lb)
Mounting	DIN rail (IEC/EN 60715), 35 mm or screw mounting with fixing brackets CL-LAS.FD001 (accessories)		
Mounting position	horizontal / vertical		
Electrical connection			
Wire size	rigid fine-strand with wire end ferrule	0.2-4 mm ² (22-12 AWG) 0.2-2.5 mm ² (22-12 AWG)	
Max. tightening torque	0.6 Nm		
Environmental data			
Ambient temperature range	operation storage	-25...+55 °C, cold acc. to IEC 60068-2-1, heat acc. to IEC 60068-2-2 -40...+70 °C	
LCD-Display (clearly legible)	0...+55 °C		
Condensation	avoid condensation with suitable methods		
Humidity, no condensation (IEC/EN 60068-2-30)	5-95 %		
Air pressure (operation)	795-1080 hPa		
Degree of protection (IEC/EN 60529)	IP20		
Vibration (IEC/EN 60068-2-6)	10-57 Hz (constant amplitude 0.15 mm), 57-150 Hz (constant acceleration 2 g)		
Shock resistance (half-sine 15 g / 11 ms) (IEC/EN 60068-2-27)	18 Shocks		
Drop (IEC/EN 60068-2-31) height of fall	50 mm		
Free fall, packaged (IEC/EN 60068-2-32)	1 m		
Insulation data			
Overvoltage category	II		
Pollution degree (DIN EN 60947)	2		
Rating of air and creepage distances	EN 50178, UL 508, CSA C22.2, No. 142		
Insulation resistance	EN 50178		
Standards			
Standards and directives	EN 55011, EN 55022, IEC/EN 61000-4, IEC 60068-2-6, IEC 60068-2-27		
Electromagnetic compatibility			
Interference immunity			
electrostatic discharge (ESD)	IEC/EN 61000-4-2	Level 3 (air discharge 8 kV, contact discharge 6 kV)	
electromag. field (HF radiation resistance)	IEC/EN 61000-4-3	10 V/m	
fast transients (Burst)	IEC/EN 61000-4-4	Level 3 (supply cable 2 kV, signal lines 2 kV)	
powerful impulses (Surge)	IEC/EN 61000-4-5	supply cable symmetrical (AC) 2 kV, Level 2 (supply cable symmetrical (DC) 0.5 kV)	
HF line emission	IEC/EN 61000-4-6	10 V	
Interference suppression (EN 55011, EN 55022)	class B		
Real time clock			
Back-up time	see diagram		-
Accuracy	typ. ±5 (±0.5 h/year)		-
Repeat accuracy of the time relay			
Accuracy (from value)	±1		-
Resolution	range „S“	10 ms	-
	range „M: S“	1 s	-
	range „H: M“	1 min	-
Retention behaviour			
Write cycles of retention memory (minimum)	1.000.000 (10 ⁶)		-

Technical diagram

Back-up time of the real time clock

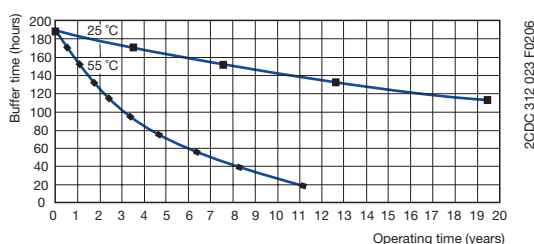

Logic relays

Technical data

Data at T_a = 25 °C and rated values, if nothing else indicated.

Type	CL-LDD...	
Input circuit - Supply circuit		
Power failure buffering (IEC/EN 61131-2)	10 ms	
General data		
Dimensions (W x H x D)	with keypad: 86.5 x 86.5 x 21.5 mm (3.41 x 3.41 x 0.85 inch) without keypad: 86.5 x 86.5 x 20 mm (3.41 x 3.41 x 0.79 inch)	
Weight	0.13 kg (0.29 lb)	
Mounting	2 x 22.5 mm, with 2 retainers screwed	
Mounting position	horizontal / vertical	
Environmental data		
Ambient temperature range	operation	-25...+55 °C (cold acc. to IEC 60068-2-1, heat acc. to IEC 60068-2-2)
	storage	-40...+70 °C
LCD-Display (clearly legible)	-5...+50 °C, -10...0 °C (with backlit / continuous operation)	
Condensation	avoid condensation with suitable methods	
Humidity, no condensation (IEC/EN 60068-2-30)	5-95 %	
Air pressure (operation)	795-1080 hPa	
Degree of protection (IEC/EN 60529)	IP65	
Vibration (IEC/EN 60068-2-6)	10-57 Hz (constant amplitude 0.15 mm), 57-150 Hz (constant acceleration 2 g)	
Shock resistance (half-sine 15 g / 11 ms) (IEC/EN 60068-2-27)	18 Shocks	
Drop (IEC/EN 60068-2-31) height of fall	50 mm	
Free fall, packaged (IEC/EN 60068-2-32)	1 m	
Insulation data		
Pollution degree (DIN EN 60947)	3	
Rating of air and creepage distances	EN 50178, UL 508, CSA 22.2, No 142	
Insulation resistance	EN 50178	
Standards		
Standards and directives	EN 61000-6-1, EN 61000-6-2, EN 61000-6-3, EN 61000-6-4, IEC 60068-2-6, IEC 60068-2-27	
Electromagnetic compatibility		
Interference immunity		
electrostatic discharge (ESD)	IEC/EN 61000-4-2	Level 3 (air discharge 8 kV, contact discharge 6 kV)
electromag. field (HF radiation resistance)	IEC/EN 61000-4-3	10 V/m
fast transients (Burst)	IEC/EN 61000-4-4	Level 3 (supply cable 2 kV, signal lines 2 kV)
powerful impulses (Surge)	IEC/EN 61000-4-5	Level 3 (supply cable symmetrical 2 kV, CL-LDC.L...AC2) Level 2 (0.5 kV supply cable symmetrical, CL-LDC.L...AC2)
HF line emission	IEC/EN 61000-4-6	10 V
Interference suppression (EN 55011, EN 55022)	class B	

Logic relays

Technical data

Data at $T_a = 25\text{ °C}$ and rated values, if nothing else indicated.

Type	CL-LDC.SDC2	CL-LDC.SAC2	CL-LDC.LDC2	CL-LDC.LAC2	CL-LDC.LNDC2	CL-LDC.LNAC2
Input circuit - Supply circuit						
Rated operational voltage U_o	24 V DC	100-240 V AC	24 V DC	100-240 V AC	24 V DC	100-240 V AC
Rated operational voltage tolerance	-15...+20 %	-15...+10 %	-15...+20 %	-15...+10 %	-15...+20 %	-15...+10 %
Operational voltage range	20.4-28.8 V DC	85-264 V AC	20.4-28.8 V DC	85-264 V AC	20.4-28.8 V DC	85-264 V AC
Frequency	0 Hz	50/60 Hz	0 Hz	50/60 Hz	0 Hz	50/60 Hz
Frequency tolerance	-	± 5 %	-	± 5 %	-	± 5 %
Residual ripple	≤ 5 %	-	≤ 5 %	-	≤ 5 %	-
Input current	at 24 V DC typ. 185 mA	-	at 24 V DC typ. 200 mA	-	at 24 V DC typ. 200 mA	-
	at 115/120 V AC (60 Hz)	typ. 90 mA	at 115/120 V AC (60 Hz)	typ. 90 mA	at 115/120 V AC (60 Hz)	typ. 90 mA
	at 230/240 V AC (50 Hz)	typ. 60 mA	at 230/240 V AC (50 Hz)	typ. 60 mA	at 230/240 V AC (50 Hz)	typ. 60 mA
Power failure buffering (IEC/EN 61131-2)	10 ms	-	10 ms	-	10 ms	-
Power dissipation	at 24 V DC 1.5 W	-	at 24 V DC 3.4 W	-	at 24 V DC 3.4 W	-
	at 115/120 V AC	typ. 11 VA	at 115/120 V AC	typ. 11 VA	at 115/120 V AC	typ. 11 VA
	at 230/240 V AC	typ. 15 VA	at 230/240 V AC	typ. 15 VA	at 230/240 V AC	typ. 15 VA
Network - point-to-point connection						
Number of stations	1	-	1	-	1	-
Data transfer rate	CL-LS..., CL-LM... 9.6 kBaud	-	CL-LDD 19.2 kBaud	-	CL-LDD 19.2 kBaud	-
Distance	max. 5 m	-	max. 5 m	-	max. 5 m	-
Electrical isolation	to voltage supply yes	-	to voltage supply yes	-	to voltage supply yes	-
	to connected device yes	-	to connected device yes	-	to connected device yes	-
Termination system	spring-type terminal	-	spring-type terminal	-	spring-type terminal	-
Network - CL-NET						
Number of stations	max. 1	-	max. 1	-	max. 8	-
Data transfer rate	6 m 25 m 40 m 125 m 300 m 700 m 1000 m	-	6 m 25 m 40 m 125 m 300 m 700 m 1000 m	-	1000 kBit/s 500 kBit/s 250 kBit/s 125 kBit/s 50 kBit/s 20 kBit/s 10 kBit/s	-
Electrical isolation	to voltage supply to inputs to outputs to PC interface, memory module, CL-NET, CL-LINK	- - - -	to voltage supply to inputs to outputs to PC interface, memory module, CL-NET, CL-LINK	- - - -	yes yes yes yes	-
Bus terminator (first and last station)	-	-	-	-	yes	-
Termination system	-	-	-	-	RJ45, 8 pole	-
General data						
Dimensions (W x H x D)	75 x 58 x 36.2 mm (2.95 x 2.28 x 1.43 inch)	-	107.5 x 90 x 30 mm (4.23 x 3.54 x 1.18 inch)	-	107.5 x 90 x 30 mm (4.23 x 3.54 x 1.18 inch)	-
Weight	0.164 kg (0.36 lb)	-	0.145 kg (0.32 lb)	-	0.145 kg (0.32 lb)	-
Mounting	plugged onto CL-LDD	-	plugged onto CL-LDD or on DIN rail (IEC/EN 60715)	-	plugged onto CL-LDD or on DIN rail (IEC/EN 60715)	-
Mounting position	-	-	-	-	-	-
Electrical connection - Supply circuit						
Wire size	fine-strand with wire end ferrule	0.2 mm ² / 2.5 mm ² (24-12 AWG)	0.2 mm ² / 2.5 mm ² (24-12 AWG)	-	0.2 mm ² / 2.5 mm ² (24-12 AWG)	-
	rigid	0.2 mm ² / 4 mm ² (24-12 AWG)	0.2 mm ² / 4 mm ² (24-12 AWG)	-	0.2 mm ² / 4 mm ² (24-12 AWG)	-
Electrical connection - Data cable						
Wire size	fine-strand with wire end ferrule	0.08 mm ² / 1.5 mm ² (28-12 AWG)	0.08 mm ² / 1.5 mm ² (28-12 AWG)	-	0.2 mm ² / 2.5 mm ² (24-12 AWG)	-
	rigid	0.08 mm ² / 2.5 mm ² (28-12 AWG)	0.08 mm ² / 2.5 mm ² (28-12 AWG)	-	0.2 mm ² / 4 mm ² (24-12 AWG)	-
Environmental data						
Ambient temperature range	operation storage	-25...+55 °C (cold acc. to IEC 60068-2-1, heat acc. to IEC 60068-2-2) -40...+70 °C	-25...+55 °C (cold acc. to IEC 60068-2-1, heat acc. to IEC 60068-2-2) -40...+70 °C	-	-25...+55 °C (cold acc. to IEC 60068-2-1, heat acc. to IEC 60068-2-2) -40...+70 °C	-
Condensation	-	avoid condensation with suitable methods	avoid condensation with suitable methods	-	avoid condensation with suitable methods	-
Humidity, no condensation (IEC/EN 60068-2-30)	-	5-95 %	5-95 %	-	5-95 %	-
Air pressure (operation)	-	795-1080 hPa	795-1080 hPa	-	795-1080 hPa	-
Degree of protection (IEC/EN 60529)	-	IP20	IP20	-	IP20	-
Vibration (IEC/EN 60068-2-6)	-	10-57 Hz (constant amplitude 0.15 mm), 57-150 Hz (constant acceleration 2 g)	10-57 Hz (constant amplitude 0.15 mm), 57-150 Hz (constant acceleration 2 g)	-	10-57 Hz (constant amplitude 0.15 mm), 57-150 Hz (constant acceleration 2 g)	-

Logic relays

Technical data

Data at $T_a = 25\text{ °C}$ and rated values, if nothing else indicated.

Type	CL-LDC. SDC2	CL-LDC. SAC2	CL-LDC. LDC2	CL-LDC. LAC2	CL-LDC. LNDC2	CL-LDC. LNAC2
Shock (half-sine 15 g / 11 ms) (IEC/EN 60068-2-27)	18 Shocks					
Drop (IEC/EN 60068-2-31) height of fall	50 mm					
Free fall, packaged (IEC/EN 60068-2-32)	1 m					
Insulation data						
Degree of protection (DIN EN 60947)	2					
Rating of air and creepage distances	EN 50178, UL 508, CSA 22.2, No 142					
Isolation resistance	EN 50178					
Standards						
Standards and directives	EN 61000-6-1, EN 61000-6-2, EN 61000-6-3, EN 61000-6-4, IEC 60068-2-6, IEC 60068-2-27					
Electromagnetical compatibility						
Interference immunity						
electrostatic discharge (ESD)	IEC/EN 61000-4-2	Level 3 (air discharge 8 kV, contact discharge 6 kV)				
electromag. field (HF radiation resistance)	IEC/EN 61000-4-3	10 V/m				
fast transients (Burst)	IEC/EN 61000-4-4	Level 3 (supply cable 2 kV, signal lines 2 kV)				
powerful impulses (Surge)	IEC/EN 61000-4-5	Level 3 (supply cable symmetrical 2 kV, CL-LDC.L...AC2)		Level 2 (1 kV supply cable symmetrical) Level 2 (0.5 kV supply cable symmetrical, CL-LDC.L...AC2)		
HF line emission	IEC/EN 61000-4-6	10 V				
Interference suppression (EN 55011, EN 55022)	class B					
Real time clock						
Back-up time	-		see diagram			
Accuracy	-		typ. ± 5 s/day ($\pm 0,5$ h/year)			
Repeat accuracy of the time relay						
Accuracy (from value)	-		$\pm 0.02\%$			
Resolution	range „S“		5 ms			
	range „M:S“		1 s			
	range „H:M“		1 min			
Retention behaviour						
Write cycles of retention memory (minimum)	-		10^{10} (read/ write cycles)			

6

Technical diagram

Back-up time of the real time clock

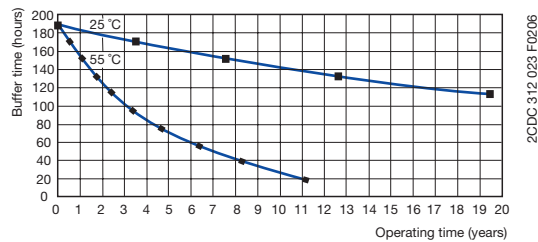

Logic relays

Technical data

Data at $T_a = 25\text{ °C}$ and rated values, if nothing else indicated.

Type	CL-LD...16DC2	CL-LD...17DC2	CL-LDR.16AC2
Input circuit - Digital inputs	24 V DC		115/230 V
Number	12		
Inputs can be used as analog inputs	4 (I7, I8, I11, I12)		
Indication of operational states	-		
Electrical isolation	from supply voltage	no	LCD-Display (if existing)
	from digital inputs	no	
	from the outputs	yes	
	from PC interface, memory module, CL-NET, CL-LINK	yes	
Rated operational voltage U_e	24 V DC		-
	U_e on „0“ signal	< 5 V DC (I1-I6, I9, I10), < 8 V DC (I7, I8, I11, I12)	0-40 V AC (sinusoidal)
	U_e on „1“ signal	> 15 V DC (I1-I6, I9, I10), > 8 V DC (I7, I8, I11, I12)	79-264 V AC (sinusoidal)
Rated frequency	0 Hz		50-60 Hz
Input current on „1“ signal	3.3 mA (at 24 V DC, I1-I6, I9, I10), 2.2 mA (at 24 V DC, I7, I8, I11, I12)		12x0.2 mA (at 115 V AC, 60 Hz, I1-I12), 12x0.5 mA (at 230 V AC, 50 Hz, I1-I12)
Time delay from „0“ to „1“	debounce ON	20 ms	10 ms (at 50 Hz), 100 ms (at 60 Hz)
	debounce OFF	typ. 0.1 ms (I1-I4), typ. 0.25 ms (I5-I12)	10 ms (at 50 Hz), 100 ms (at 60 Hz)
Time delay from „1“ to „0“	debounce ON	20 ms	10 ms (at 50 Hz), 100 ms (at 60 Hz)
	debounce OFF	typ. 0.1 ms (I1-I4), typ. 0.4 ms (I5, I6, I9, I10), typ. 0.2 ms (I7, I8, I11, I12)	10 ms (at 50 Hz), 100 ms (at 60 Hz)
Cable length (unshielded)	100 m		-
Maximum cable length per input	-		typ. 60 m
Frequency counter	number	4 (I1, I2, I3, I4)	-
	counting frequency	< 3 kHz	-
	pulse shape	square-wave	-
	pulse / pause ratio	1:1	-
Incremental counter	number	2 (I1 + I2, I3 + I4)	-
	counting frequency	< 3 kHz	-
	pulse shape	square-wave	-
	signal offset	90°	-
	pulse / pause ratio	1:1	-
Rapid counter inputs	number	4 (I1, I2, I3, I4)	-
	counting frequency	< 3 kHz	-
	pulse shape	square-wave	-
	pulse / pause ratio	1:1	-
Cable length (shielded)	< 20 m		-
Input circuit - Analog inputs			
Number	4 (I7, I8, I11, I12)		
Electrical isolation	to voltage supply	no	-
	to digital inputs	no	-
	to outputs	yes	-
	to PC interface, memory modul, CL-NET, CL-LINK	yes	-
Input type	DC voltage		
Signal range	0-10 V DC		
Resolution	analog	0.01 V	-
	digital	0.01 V; 10 Bit (value 0-1023)	-
Input impedance	11.2 k Ω		
Accuracy of the actual value	two CL-LD... devices	$\pm 3\%$	-
	within one device	$\pm 2\%$	-
Conversion time analog/digital	each cycle		
Input current	< 1 mA		
Cable length (shielded)	< 30 m		

Logic relays

Technical data

Data at T_a = 25 °C and rated values, if nothing else indicated.

Type		CL-LD...16DC2	CL-LD...17DC2	CL-LDR.16AC2
Output circuit - Analog outputs				
Number		-	1	-
Electrical separation	from voltage supply	-	no	-
	from the digital inputs	-	no	-
	from the digital outputs	-	yes	-
	from PC interface, memory module, CL-NET, CL-LINK	-	yes	-
Output type		-	DC voltage	-
Signal range		-	0-10 V DC	-
Max. output current		-	0.01 A	-
Burden resistance		-	1 kΩ	-
Overload and short-circuit protection		-	yes	-
Resolution	analog	-	0.01 V DC	-
	digital	-	10 Bit, (value: 0-1023)	-
Setting time		-	100 ms	-
Accuracy	-25...+55 °C	-	2 %	-
	25 °C	-	1 %	-
Conversion time		-	each CPU cycle	-
General data				
Dimensions (W x H x D)		CL-LDR: 89 x 90 x 44 mm (3.5 x 3.54 x 1.73 inch) CL-LDT (build-in): 89 x 90 x 25 mm (3.5 x 3.54 x 0.98 inch)		89 x 90 x 44 mm (3.5 x 3.54 x 1.73 inch)
Weight		CL-LDR: 0.15 kg (0.33 lb) / CL-LDT: 0.14 kg (0.31 lb)		0.15 kg (0.33 lb)
Mounting		snap-on power supply unit		
Mounting position		horizontal / vertical		
Electrical connection				
Wire size	fine-strand with wire end ferrule	0.2 mm ² / 2.5 mm ² (24-12 AWG)		
	rigid	0.2 mm ² / 4 mm ² (24-12 AWG)		
Electrical connection - Data cable				
Wire size	fine-strand with wire end ferrule	0.08 mm ² / 1.5 mm ² (28-12 AWG)		
	rigid	0.08 mm ² / 2.5 mm ² (28-12 AWG)		
Environmental data				
Ambient temperature range	operation	-25...+55 °C (cold acc. to IEC 60068-2-1, heat acc. to IEC 60068-2-2)		
	storage	-40...+70 °C		
Condensation		avoid condensation with suitable methods		
Humidity, no condensation (IEC/EN 60068-2-30)		5-95 %		
Atmospheric pressure (operation)		795-1080 hPa		
Degree of protection (IEC/EN 60529)		IP20		
Vibration (IEC/EN 60068-2-6)		10-57 Hz (constant amplitude 0.15 mm), 57-150 Hz (constant acceleration 2 g)		
Shock (half-sine 15 g / 11 ms) (IEC/EN 60068-2-27)		18 Shocks		
Drop (IEC/EN 60068-2-31) height of fall		50 mm		
Free fall, packaged (IEC/EN 60068-2-32)		1 m		
Insulation data				
Pollution degree		2		
Rating of air and creepage distances		EN 50178, UL 508, CSA C22.2, No. 142		
Isolation resistance		EN 50178		
Standards				
Standards and directives		EN 61000-6-1/-2/-3/-4, IEC/EN 61000-4, IEC 60068-2-6, IEC 60068-2-27		
Electromagnetic compatibility				
electrostatic discharge (ESD)	IEC/EN 61000-4-2	Level 3 (air discharge 8 kV, contact discharge 6 kV)		
electromag. field (HF radiation res.)	IEC/EN 61000-4-3	10 V/m		
fast transients (Burst)	IEC/EN 61000-4-4	Level 3 (supply cable 2 kV, signal cable 2 kV)		
powerful impulses (Surge)	IEC/EN 61000-4-5	2 kV (supply cable symmetrical), Level 2 (0.5 kV supply cable symmetrical)		
HF line emission	IEC/EN 61000-4-6	10 V		
Interference suppression (EN 55011, EN 55022)		class B		

Logic relays

Technical data

Data at $T_a = 25\text{ °C}$ and rated values, if nothing else indicated.

Type	CL-LDR...	
Output circuit - Relay outputs		
Number	4	
Outputs in groups of	-	
Parallel switching of outputs to increase capacity	not permissible	
Fusing of the output relay	circuit-breaker B16 or fuse 8 A (slow-acting)	
Electrical isolation	from voltage supply	yes
	from the inputs	yes
	from PC interface, memory module, CL-NET, CL-LINK	yes
	protective separation	300 V AC
	Basic isolation	600 V AC
Mechanical lifetime	10×10^6 switching cycles	
Rung	conventional thermal current (10 A UL)	8 A
	recommended load 12 V AC/DC	> 500 mA
	short-circuit proof $\cos \phi = 1$; characteristic B16 at 600 A	16 A
	short-circuit proof $\cos \phi = 0.5$ up to 0.7; characteristic B16 at 900 A	16 A
	Rated impulse withstand voltage U_{imp} contact-coil	6 kV
	Rated operational voltage U_e	250 V AC
Rated insulation voltage U_i	250 V AC	
Protective separation (EN 50178)	between coil and contact	300 V AC
	between two contacts	300 V AC
Making capacity	AC-15, 250 V AC, 3 A (600 ops./h)	300.000 switching cycles
Breaking capacity	DC13, L/R ≤ 150 ms, 24 V DC, 1 A (500 ops./h)	200.000 switching cycles
	AC-15, 250 V AC, 3 A (600 ops./h)	300.000 switching cycles
Incandescent lamp load	DC13, L/R ≤ 150 ms, 24 V DC, 1 A (500 ops./h)	200.000 switching cycles
	1000 W at 230/240 V AC	25.000 switching cycles
Fluorescent lamp load	500 W at 115/120 V AC	25.000 switching cycles
	10 x 58 W at 230/240 V AC with electrical control gear	25.000 switching cycles
	10 x 58 W at 230/240 V AC uncompensated	25.000 switching cycles
	1 x 58 W at 230/240 V AC conventional compensated	25.000 switching cycles
	1 x 58 W at 230/240 V AC mechanical operations	10×10^6
Switching frequency	switching frequency	10 Hz
	resistive load / lamp load	2 Hz
	inductive load	0.5 Hz
UL/CSA		
Continuous current at 240 V	10 A AC	
Continuous current at 24 V	8 A DC	
AC	Utilization category (Control Circuit Rating Codes)	B 300 Light Pilot Duty
	max. rated operational voltage	300 V AC
	max. continuous thermal current $\cos \phi = 1$ at B 300	5 A
	max. making / breaking apparent power (Make/Break) $\cos \phi \neq 1$ at B 300	3600/360 VA
DC	Utilization category (Control Circuit Rating Codes)	R 300 Light Pilot Duty
	max. rated operational voltage	300 V DC
	max. continuous thermal current at R 300	1 A
	max. making / breaking apparent power (Make/Break) at R 300	28/28 VA

Logic relays

Technical data

Data at $T_a = 25\text{ °C}$ and rated values, if nothing else indicated.

Type	CL-LDT...
Output circuit - Transistor outputs	
Number	4
Rated operational voltage U_o	24 V DC
Operational voltage range	20.4-28.8 V DC
Residual ripple	-
Supply current	on „0“ signal typ. 18 mA / max. 32 mA on „1“ signal typ. 24 mA / max. 44 mA
Reverse voltage protection	yes (Attention: If supply voltage is reversed, applying voltage at the outputs, causes a short circuit.)
Electrical isolation	from voltage supply yes from the inputs yes from PC interface, memory module, CL-NET, CL-LINK yes
Rated operational current I_o on „1“ signal DC	max. 0.5 A
Lamp load without R_v	5 W (Q1-Q4)
Residual current on „0“ signal per channel	< 0.1 mA
Max. output voltage	on „0“ signal at external load < 10 M Ω 2.5 V on „1“ signal at $I_o = 0.5\text{ A}$ $U = U_o - 1\text{ V}$
Short-circuit protection	thermal (Q1-Q4), (analysis results from diagnosis input I16)
Short-circuit tripping current for $R_a \leq 10\text{ m}\Omega$	$0.7\text{ A} \leq I_e \leq 2\text{ A}$ per output
Total short-circuit current	8 A
Peak short-circuit current	16 A
Thermal tripping	yes
Max. switching frequency with constant resistive load $R_L < 100\text{ k}\Omega$ (depending on active channels and their load)	40.000 switching cycles/h
Parallel connection of outputs	with resistive load, inductive load with external suppressor, combination within one group number of outputs max. 4 max. total current 2 A (Attention! Outputs must be actuated simultaneously and for the same length of time.)
Indication of operational states of the outputs	LCD-Display (if existing)
Inductive load ¹⁾ without external suppressor	
$T_{0.95} = 1\text{ ms}$, $R = 48\ \Omega$, $L = 16\text{ mH}$	utilization factor 0.25 g duty time 100 % max. switching frequency $f = 0.5\text{ Hz}$ 1500 switching cycles (max. duty time = 50 %)
DC13, $T_{0.95} = 72\text{ ms}$, $R = 48\ \Omega$, $L = 1.15\text{ H}$	utilization factor 0.25 g duty time 100 % max. switching frequency $f = 0.5\text{ Hz}$ 1500 switching cycles (max. duty time = 50 %)
$T_{0.95} = 15\text{ ms}$, $R = 48\ \Omega$, $L = 0.24\text{ H}$	utilization factor 0.25 g duty time 100 % max. switching frequency $f = 0.5\text{ Hz}$ 1500 switching cycles (max. duty time = 50 %)
Inductive load ¹⁾ with external suppressor	demand factor 1 g duty time 100 % max. switching frequency max. duty time depends on suppressor

¹⁾ For inductive loading, without external suppression of the transistor outputs, the following applies:

$T_{0.95}$ = time in ms, until 95 % of the steady-state current is achieved. $T_{0.95} \cdot 3 \times T_{0.65} = 3 \times L/R$.

Data transfer rate in the CL-NET network: bus lengths of 40 m and over only attainable with cables with additional cross-section and connection adapter.

Logic relays

Dimensional drawings

Dimensional drawings

dimensions in mm

CL-LSR, CL-LST

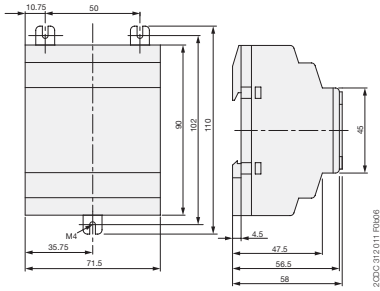

CL-LMR, CL-LMT

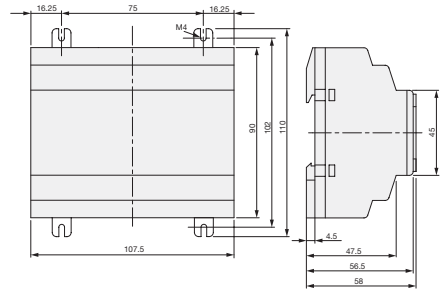

CL-LER.20

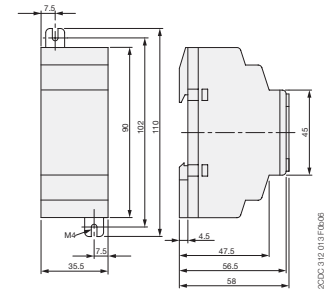

CL-LDD

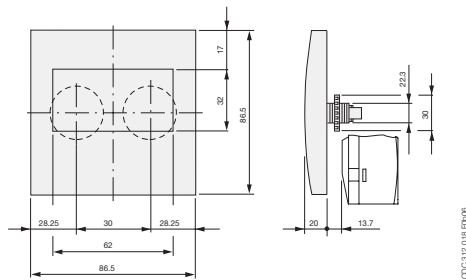

CL-LDD.K + CL-LDC.L.. +
(CL-LDR or CL-LDT)

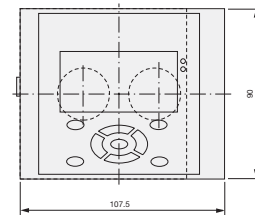

CL-LDC.S..

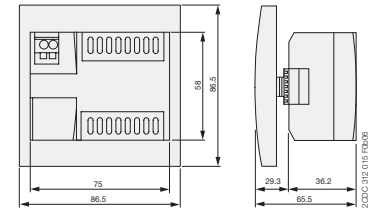

CL-LDR, CL-LDT

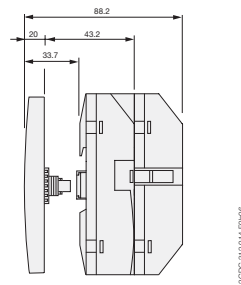
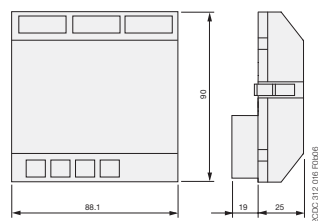

KLINKMANN

Helsinki
tel. +358 9 540 4940
automation@klinkmann.fi

Yekaterinburg
tel. +7 343 287 19 19
yekaterinburg@klinkmann.spb.ru

Vilnius
tel. +370 5 215 1646
post@klinkmann.lt

St. Petersburg
tel. +7 812 327 3752
klinkmann@klinkmann.spb.ru

Samara
tel. +7 846 273 95 85
samara@klinkmann.spb.ru

Tallinn
tel. +372 668 4500
klinkmann.est@klinkmann.ee

Moscow
tel. +7 495 641 1616
moscow@klinkmann.spb.ru

Kiev
tel. +38 044 495 33 40
klinkmann@klinkmann.kiev.ua

Minsk
tel. +375 17 200 0876
minsk@klinkmann.com

Riga
tel. +371 6738 1617
klinkmann@klinkmann.lv